



HT32F52231/HT32F52241 HT32F52331/HT32F52341 Datasheet

**32-Bit Arm® Cortex®-M0+ Microcontroller,
up to 64 KB Flash and 8 KB SRAM with 1 MSPS ADC,
USART, UART, SPI, I²C, MCTM, GPTM, SCTM, BFTM,
SCI, CRC, RTC, WDT, and USB2.0 FS**

Revision: V2.00 Date: March 20, 2023

www.holtek.com

Table of Contents

1 General Description	6
2 Features	7
Core	7
On-chip Memory	7
Flash Memory Controller – FMC.....	7
Reset Control Unit – RSTCU	7
Clock Control Unit – CKCU.....	8
Power Management – PWRCU	8
External Interrupt/Event Controller – EXTI	8
Analog to Digital Converter – ADC	9
I/O Ports – GPIO.....	9
Motor Control Timer – MCTM	9
General-Purpose Timer – GPTM	10
Single Channel Timer – SCTM	10
Basic Function Timer – BFTM	10
Watchdog Timer – WDT.....	10
Real Time Clock – RTC	11
Inter-integrated Circuit – I ² C	11
Serial Peripheral Interface – SPI	11
Universal Synchronous Asynchronous Receiver Transmitter – USART	12
Universal Asynchronous Receiver Transmitter – UART	12
Smart Card Interface – SCI (HT32F52331/52341 only)	13
Cyclic Redundancy Check – CRC	13
Universal Serial Bus Device Controller – USB (HT32F52331/52341 only)	13
Debug Support.....	14
Package and Operation Temperature	14
3 Overview	15
Device Information	15
Block Diagram	16
Memory Map	17
Clock Structure	20
4 Pin Assignment	21

5 Electrical Characteristics	31
Absolute Maximum Ratings	31
Recommended DC Operating Conditions	31
On-Chip LDO Voltage Regulator Characteristics.....	31
Power Consumption	32
Reset and Supply Monitor Characteristics.....	33
External Clock Characteristics	34
Internal Clock Characteristics	35
PLL Characteristics	35
Memory Characteristics	35
I/O Port Characteristics.....	36
ADC Characteristics	37
SCTM/GPTM/MCTM Characteristics.....	38
I ² C Characteristics	38
SPI Characteristics	39
USB Characteristics.....	41
6 Package Information	42
24-pin SSOP (150mil) Outline Dimensions.....	43
28-pin SSOP (150mil) Outline Dimensions.....	44
SAW Type 33-pin (4mm×4mm) QFN Outline Dimensions.....	45
48-pin LQFP (7mm×7mm) Outline Dimensions.....	46

List of Tables

Table 1. Features and Peripheral List	15
Table 2. Register Map	18
Table 3. HT32F52231/52241 Series Pin Assignment for 24/28SSOP, 33QFN, 48LQFP Package.....	27
Table 4. HT32F52331/52341 Series Pin Assignment for 33QFN, 48LQFP Package	28
Table 5. HT32F52231/52241 Pin Description	29
Table 6. HT32F52331/52341 Pin Description	30
Table 7. Absolute Maximum Ratings.....	31
Table 8. Recommended DC Operating Conditions	31
Table 9. LDO Characteristics	31
Table 10. HT32F52231/52241 Power Consumption Characteristics	32
Table 11. HT32F52331/52341 Power Consumption Characteristics	32
Table 12. V _{DD} Power Reset Characteristics	33
Table 13. LVD/BOD Characteristics	33
Table 14. High Speed External Clock (HSE) Characteristics.....	34
Table 15. Low Speed External Clock (LSE) Characteristics	34
Table 16. High Speed Internal Clock (HSI) Characteristics	35
Table 17. Low Speed Internal Clock (LSI) Characteristics.....	35
Table 18. PLL Characteristics	35
Table 19. Flash Memory Characteristics.....	35
Table 20. I/O Port Characteristics	36
Table 21. ADC Characteristics	37
Table 22. SCTM/GPTM/MCTM Characteristics	38
Table 23. I ² C Characteristics.....	38
Table 24. SPI Characteristics.....	39
Table 25. USB DC Electrical Characteristics	41
Table 26. USB AC Electrical Characteristics.....	41

List of Figures

Figure 1. Block Diagram	16
Figure 2. Memory Map	17
Figure 3. Clock Structure	20
Figure 4. HT32F52231/52241 24-pin SSOP Pin Assignment	21
Figure 5. HT32F52231/52241 28-pin SSOP Pin Assignment	22
Figure 6. HT32F52231/52241 33-pin QFN Pin Assignment	23
Figure 7. HT32F52231/52241 48-pin LQFP Pin Assignment	24
Figure 8. HT32F52331/52341 33-pin QFN Pin Assignment	25
Figure 9. HT32F52331/52341 48-pin LQFP Pin Assignment	26
Figure 10. ADC Sampling Network Model	37
Figure 11. I ² C Timing Diagrams	39
Figure 12. SPI Timing Diagrams – SPI Master Mode	40
Figure 13. SPI Timing Diagrams – SPI Slave Mode with CPHA=1	40
Figure 14. USB Signal Rise Time and Fall Time and Cross-point Voltage (VCRS) Definition	41

1 General Description

The HOLTEK HT32F522x1/523x1 devices are high performance, low power consumption 32-bit microcontrollers based around an Arm® Cortex®-M0+ processor core. The Cortex®-M0+ is a next-generation processor core which is tightly coupled with Nested Vectored Interrupt Controller (NVIC), SysTick timer, and including advanced debug support.

The devices operate at a frequency of up to 40MHz for HT32F52231/52241 and 48MHz for HT32F52331/52341 with a Flash accelerator to obtain maximum efficiency. It provides up to 64KB of embedded Flash memory for code/data storage and 8 KB of embedded SRAM memory for system operation and application program usage. A variety of peripherals, such as ADC, I²C, USART, UART, SPI, MCTM, GPTM, SCTM, CRC-16/32, RTC, WDT, SCI, USB2.0 FS, SW-DP (Serial Wire Debug Port), etc., are also implemented in the device series. Several power saving modes provide the flexibility for maximum optimization between wakeup latency and power consumption, an especially important consideration in low power applications.

The above features ensure that the devices are suitable for use in a wide range of applications, especially in areas such as white goods application control, power monitors, alarm systems, consumer products, handheld equipment, data logging applications, motor control and so on.

arm CORTEX

2 Features

Core

- 32-bit Arm® Cortex®-M0+ processor core
- Up to 40MHz operating frequency for HT32F52231/52241 or 48MHz for HT32F52331/52341
- Single-cycle multiplication
- Integrated Nested Vectored Interrupt Controller (NVIC)
- 24-bit SysTick timer

The Cortex®-M0+ processor is a very low gate count, highly energy efficient processor that is intended for microcontroller and deeply embedded applications that require an area optimized, low-power processor. The processor is based on the ARMv6-M architecture and supports Thumb® instruction sets; single-cycle I/O port; hardware multiplier and low latency interrupt respond time.

On-chip Memory

- Up to 64 KB on-chip Flash memory for instruction/data and options storage
- 8 KB on-chip SRAM
- Supports multiple boot modes

The Arm® Cortex®-M0+ processor accesses and debug accesses share the single external interface to external AHB peripheral. The processor accesses take priority over debug accesses. The maximum address range of the Cortex®-M0+ is 4 GB since it has a 32-bit bus address width. Additionally, a pre-defined memory map is provided by the Cortex™-M0+ processor to reduce the software complexity of repeated implementation by different device vendors. However, some regions are used by the Arm® Cortex®-M0+ system peripherals. Refer to the Arm® Cortex®-M0+ Technical Reference Manual for more information. Figure 2 shows the memory map of the HT32F52231/52241 and HT32F52331/52341 series of devices, including code, SRAM, peripheral, and other pre-defined regions.

Flash Memory Controller – FMC

- Flash accelerator for maximum efficiency
- 32-bit word programming with In System Programming Interface (ISP) and In Application Programming (IAP)
- Flash protection capability to prevent illegal access

The Flash Memory Controller, FMC, provides all the necessary functions and pre-fetch buffer for the embedded on-chip Flash Memory. Since the access speed of the Flash Memory is slower than the CPU, a wide access interface with a pre-fetch buffer and cache are provided for the Flash Memory in order to reduce the CPU waiting time which will cause CPU instruction execution delays. Flash Memory word program/page erase functions are also provided.

Reset Control Unit – RSTCU

- Supply supervisor:
 - Power On Reset / Power Down Reset – POR/PDR
 - Brown-out Detector – BOD
 - Programmable Low Voltage Detector – LVD

The Reset Control Unit, RSTCU, has three kinds of reset, a power on reset, a system reset and an APB unit reset. The power on reset, known as a cold reset, resets the full system during power up. A system reset resets the processor core and peripheral IP components with the exception of the SW-DP controller. The resets can be triggered by an external signal, internal events and the reset generators.

Clock Control Unit – CKCU

- External 4 to 16MHz crystal oscillator
- External 32,768 Hz crystal oscillator
- Internal 8MHz RC oscillator trimmed to $\pm 2\%$ accuracy at 3.3V operating voltage and 25°C operating temperature
- Internal 32 kHz RC oscillator
- Integrated system clock PLL
- Independent clock divider and gating bits for peripheral clock sources

The Clock Control unit, CKCU, provides a range of oscillator and clock functions. These include a High Speed Internal RC oscillator (HSI), a High Speed External crystal oscillator (HSE), a Low Speed Internal RC oscillator (LSI), a Low Speed External crystal oscillator (LSE), a Phase Lock Loop (PLL), a HSE clock monitor, clock prescalers, clock multiplexers, APB clock divider and gating circuitry. The AHB, APB and Cortex®-M0+ clocks are derived from the system clock (CK_SYS) which can come from the HSI, HSE or PLL. The Watchdog Timer and Real Time Clock (RTC) use either the LSI or LSE as their clock source.

Power Management – PWRCU

- Single V_{DD} power supply: 2.0V to 3.6V
- Integrated 1.5V LDO regulator for MCU core power, peripherals and memories power supply
- V_{DD} power supply for RTC.
- Two power domains: V_{DD} , V_{CORE}
- Four power saving modes: Sleep, Deep-Sleep1, Deep-Sleep2, Power-Down

Power consumption can be regarded as one of the most important issues for many embedded system applications. Accordingly the Power Control Unit, PWRCU, in these devices provides many types of power saving modes such as Sleep, Deep-Sleep1, Deep-Sleep2 and Power-Down mode. These operating modes reduce the power consumption and allow the application to achieve the best trade-off between the conflicting demands of MCU operating time, speed and power consumption.

External Interrupt/Event Controller – EXTI

- Up to 16 EXTI lines with configurable trigger source and type
- All GPIO pins can be selected as EXTI trigger source
- Source trigger type includes high level, low level, negative edge, positive edge, or both edge
- Individual interrupt enable, wakeup enable and status bits for each EXTI line
- Software interrupt trigger mode for each EXTI line
- Integrated deglitch filter for short pulse blocking

The External Interrupt/Event Controller, EXTI, comprises 16 edge detectors which can generate a wake-up event or interrupt requests independently. Each EXTI line can also be masked independently.

Analog to Digital Converter – ADC

- 12-bit SAR ADC engine
- Up to 1 Msps conversion rate
- Up to 12 external analog input channels

A 12-bit multi-channel ADC is integrated in the device. There are multiplexed channels, which include 12 external analog signal channels and 2 internal channels which can be measured. If the input voltage is required to remain within a specific threshold window, an Analog Watchdog function will monitor and detect these signals. An interrupt will then be generated to inform the device that the input voltage is not within the preset threshold levels. There are three conversion modes to convert an analog signal to digital data. The ADC can be operated in one shot, continuous and discontinuous conversion modes.

I/O Ports – GPIO

- Up to 40 GPIOs
- Port A, B, C are mapped as 16 external interrupts – EXTI
- Almost all I/O pins have a configurable output driving current.

There are up to 40 General Purpose I/O pins, GPIO, named from PA0 ~ PA15 to PC0 ~ PC7 for the implementation of logic input/output functions. Each of the GPIO ports has a series of related control and configuration registers to maximize flexibility and to meet the requirements of a wide range of applications.

The GPIO ports are pin-shared with other alternative functions to obtain maximum functional flexibility on the package pins. The GPIO pins can be used as alternative functional pins by configuring the corresponding registers regardless of the input or output pins. The external interrupts on the GPIO pins of the device have related control and configuration registers in the External Interrupt Control Unit, EXTI.

Motor Control Timer – MCTM

- 16-bit up/down auto-reload counter
- 16-bit programmable prescaler allowing counter clock frequency division by any factor between 1 and 65536
- Input Capture function
- Compare Match Output
- PWM waveform generation with Edge-aligned and Center-aligned Counting Modes
- Single Pulse Mode Output
- Complementary Outputs with programmable dead-time insertion
- Supports 3-phase motor control and hall sensor interface
- Break input to force the timer's output signals into a reset or fixed condition

The Motor Control Timer consists of a single 16-bit up/down counter, four 16-bit CCRs (Capture / Compare Registers), single one 16-bit counter-reload register (CRR), single 8-bit repetition counter and several control / status registers. It can be used for a variety of purposes including measuring the pulse widths of input signals or generating output waveforms such as compare match outputs, PWM outputs or complementary PWM outputs with dead-time insertion. The MCTM is capable of offering full functional support for motor control, hall sensor interfacing and brake input.

General-Purpose Timer – GPTM

- 16-bit up/down auto-reload counter
- 16-bit programmable prescaler allowing counter clock frequency division by any factor between 1 and 65536
- Input Capture function
- Compare Match Output
- PWM waveform generation with Edge-aligned and Center-aligned Counting Modes
- Single Pulse Mode Output
- Encoder interface controller with two inputs using quadrature decoder

The General-Purpose Timer consists of one 16-bit up / down-counter, four 16-bit Capture / Compare Registers (CCRs), one 16-bit Counter Reload Register (CRR) and several control/status registers. They can be used for a variety of purposes including general time measurement, input signal pulse width measurement, output waveform generation such as single pulse generation, or PWM output generation. The GPTM supports an Encoder Interface using a decoder with two inputs.

Single Channel Timer – SCTM

- 16-bit up and auto-reload counter
- One channel for each timer
- 16-bit programmable prescaler allowing counter clock frequency division by any factor between 1 and 65536
- Input Capture function
- Compare Match Output
- PWM waveform generation with Edge-aligned
- Single Pulse Mode Output

The Single-Channel Timer consists of one 16-bit up-counter, one 16-bit Capture/Compare Register (CCR), one 16-bit Counter-Reload Register (CRR) and several control/status registers. It can be used for a variety of purposes including general timer, input signal pulse width measurement or output waveform generation such as single pulse generation or PWM output.

Basic Function Timer – BFTM

- 32-bit compare/match count-up counter - no I/O control features
- One shot mode - counting stops after a match condition
- Repetitive mode - restart counter after a match condition

The Basic Function Timer is a simple count-up 32-bit counter designed to measure time intervals and generate a one shot or repetitive interrupts. The BFTM operates in two functional modes, repetitive or one shot mode. In the repetitive mode the BFTM restarts the counter when a compare match event occurs. The BFTM also supports a one shot mode which forces the counter to stop counting when a compare match event occurs.

Watchdog Timer – WDT

- 12-bit down counter with 3-bit prescaler
- Reset event for the system
- Programmable watchdog timer window function
- Register write protection function

The Watchdog Timer is a hardware timing circuit that can be used to detect system failures due to software malfunctions. It includes a 12-bit count-down counter, a prescaler, a WDT delta value register, WDT operation control circuitry and a WDT protection mechanism. If the software does not reload the counter value before a Watchdog Timer underflow occurs, a reset will be generated when the counter underflows. In addition, a reset is also generated if the software reloads the counter when the counter value is greater than the WDT delta value. This means the counter must be reloaded within a limited timing window using a specific method. The Watchdog Timer counter can be stopped while the processor is in the debug mode. There is a register write protect function which can be enabled to prevent it from changing the Watchdog Timer configuration unexpectedly.

Real Time Clock – RTC

- 24-bit up-counter with a programmable prescaler
- Alarm function
- Interrupt and Wake-up event

The Real Time Clock, RTC, includes an APB interface, a 24-bit count-up counter, a control register, a prescaler, a compare register and a status register. Most of the RTC circuits are located in the Backup Domain except for the APB interface. The APB interface is located in the V_{CORE} power domain. Therefore, it is necessary to be isolated from the ISO signal that comes from the power control unit when the V_{CORE} power domain is powered off, that is when the device enters the Power-Down mode. The RTC counter is used as a wakeup timer to generate a system resume signal from the Power-Down mode.

Inter-integrated Circuit – I²C

- Supports both master and slave modes with a frequency of up to 1 MHz
- Provide an arbitration function and clock synchronization
- Supports 7-bit and 10-bit addressing modes and general call addressing
- Supports slave multi-addressing mode with maskable address

The I²C is an internal circuit allowing communication with an external I²C interface which is an industry standard two line serial interface used for connection to external hardware. These two serial lines are known as a serial data line, SDA, and a serial clock line, SCL. The I²C module provides three data transfer rates: (1) 100kHz in the Standard mode, (2) 400kHz in the Fast mode and (3) 1MHz in the Fast plus mode. The SCL period generation register is used to setup different kinds of duty cycle implementations for the SCL pulse.

The SDA line which is connected directly to the I²C bus is a bi-directional data line between the master and slave devices and is used for data transmission and reception. The I²C also has an arbitration detect function and clock synchronization to prevent situations where more than one master attempts to transmit data to the I²C bus at the same time.

Serial Peripheral Interface – SPI

- Supports both master and slave mode
- Frequency of up to $(f_{PCLK}/2)$ MHz for the master mode and $(f_{PCLK}/3)$ MHz for the slave mode
- FIFO Depth: 8 levels
- Multi-master and multi-slave operation

The Serial Peripheral Interface, SPI, provides an SPI protocol data transmit and receive function in both master and slave mode. The SPI interface uses 4 pins, which are the serial data input and output lines MISO and MOSI, the clock line, SCK, and the slave select line, SEL. One SPI device

acts as a master device which controls the data flow using the SEL and SCK signals to indicate the start of data communication and the data sampling rate. To receive a data byte, the streamed data bits are latched on a specific clock edge and stored in the data register or in the RX FIFO. Data transmission is carried out in a similar way but in a reverse sequence. The mode fault detection provides a capability for multi-master applications.

Universal Synchronous Asynchronous Receiver Transmitter – USART

- Supports both asynchronous and clocked synchronous serial communication modes
- Asynchronous operating baud rate up to $(f_{\text{CLK}}/16)$ MHz and synchronous operating rate up to $(f_{\text{CLK}}/8)$ MHz
- Full duplex communication
- Fully programmable serial communication characteristics including:
 - Word length: 7, 8, or 9-bit character
 - Parity: Even, odd, or no-parity bit generation and detection
 - Stop bit: 1 or 2 stop bit generation
 - Bit order: LSB-first or MSB-first transfer
- Error detection: Parity, overrun, and frame error
- Auto hardware flow control mode – RTS, CTS
- IrDA SIR encoder and decoder
- RS485 mode with output enable control
- FIFO Depth: 8-level for both receiver and transmitter

The Universal Synchronous Asynchronous Receiver Transceiver, USART, provides a flexible full duplex data exchange using synchronous or asynchronous data transfer. The USART is used to translate data between parallel and serial interfaces, and is commonly used for RS232 standard communication. The USART peripheral function supports four types of interrupt including Line Status Interrupt, Transmitter FIFO Empty Interrupt, Receiver Threshold Level Reaching Interrupt and Time Out Interrupt. The USART module includes an 8-level transmitter FIFO, (TX_FIFO) and an 8-level receiver FIFO (RX_FIFO). The software can detect a USART error status by reading the Line Status Register, LSR. The status includes the type and the condition of transfer operations as well as several error conditions resulting from Parity, Overrun, Framing and Break events.

Universal Asynchronous Receiver Transmitter – UART

- Asynchronous serial communication operating baud-rate up to $f_{\text{CLK}}/16$ MHz
- Full duplex communication
- Fully programmable serial communication characteristics including:
 - Word length: 7, 8, or 9-bit character
 - Parity: Even, odd, or no-parity bit generation and detection
 - Stop bit: 1 or 2 stop bit generation
 - Bit order: LSB-first or MSB-first transfer
- Error detection: Parity, overrun, and frame error

The Universal Asynchronous Receiver Transceiver, UART, provides a flexible full duplex data exchange using asynchronous transfer. The UART is used to translate data between parallel and serial interfaces, and is commonly used for RS232 standard communication. The UART peripheral function supports Line Status Interrupt. The software can detect a UART error status by reading the Line Status Register, LSR. The status includes the type and the condition of transfer operations as well as several error conditions resulting from Parity, Overrun, Framing and Break events.

Smart Card Interface – SCI (HT32F52331/52341 only)

- Supports ISO 7816-3 standard
- Character mode
- Single transmit buffer and single receive buffer
- 11-bit ETU (elementary time unit) counter
- 9-bit guard time counter
- 24-bit general purpose waiting time counter
- Parity generation and checking
- Automatic character retry on parity error detection in transmission and reception modes

The Smart Card Interface is compatible with the ISO 7816-3 standard. This interface includes Card Insertion/Removal detection, SCI data transfer control logic and data buffers, internal Timer Counters and corresponding control logic circuits to perform all the necessary Smart Card operations. The Smart Card interface acts as a Smart Card Reader to facilitate communication with the external Smart Card. The overall functions of the Smart Card interface are controlled by a series of registers including control and status registers together with several corresponding interrupts which are generated to get the attention of the microcontroller for SCI transfer status.

Cyclic Redundancy Check – CRC

- Support CRC16 polynomial: $0x8005$,
 $X^{16}+X^{15}+X^2+1$
- Support CCITT CRC16 polynomial: $0x1021$,
 $X^{16}+X^{12}+X^5+1$
- Support IEEE-802.3 CRC32 polynomial: $0x04C11DB7$,
 $X^{32}+X^{26}+X^{23}+X^{22}+X^{16}+X^{12}+X^{11}+X^{10}+X^8+X^7+X^5+X^4+X^2+X+1$
- Supports 1's complement, byte reverse & bit reverse operation on data and checksum
- Supports byte, half-word & word data size
- Programmable CRC initial seed value
- CRC computation executed in 1 AHB clock cycle for 8-bit data and 4 AHB clock cycles for 32-bit data

The CRC calculation unit is an error detection technique test algorithm which is used to verify data transmission or storage data correctness. A CRC calculation takes a data stream or a block of data as its input and generates a 16- or 32-bit output remainder. Ordinarily, a data stream is suffixed by a CRC code and used as a checksum when being sent or stored. Therefore, the received or restored data stream is calculated by the same generator polynomial as described above. If the new CRC code result does not match the one calculated earlier, then this means that the data stream contains a data error.

Universal Serial Bus Device Controller – USB (HT32F52331/52341 only)

- Complies with USB 2.0 full-speed (12 Mbps) specification
- On-chip USB full-speed transceiver
- 1 control endpoint (EP0) for control transfer
- 3 single-buffered endpoints for bulk and interrupt transfer
- 4 double-buffered endpoints for bulk, interrupt and isochronous transfer
- 1,024 bytes EP-SRAM used as the endpoint data buffers

The USB device controller is compliant with the USB 2.0 full-speed specification. There is one control endpoint known as Endpoint 0 and seven configurable endpoints. A 1024-byte SRAM is used as the endpoint buffer. Each endpoint buffer size is programmable using corresponding registers, which provides maximum flexibility for various applications. The integrated USB full-speed transceiver helps to minimize the overall system complexity and cost. The USB functional block also contains the resume and suspend feature to meet the requirements of low-power consumption.

Debug Support

- Serial Wire Debug Port – SW-DP
- 4 comparators for hardware breakpoint or code / literal patch
- 2 comparators for hardware watchpoints

Package and Operation Temperature

- 24/28-pin SSOP, 33-pin QFN, 48-pin LQFP for HT32F52231/52241
- 33-pin QFN, 48-pin LQFP package for HT32F52331/52341
- Operation temperature range: -40°C to +85°C

3 Overview

Device Information

Table 1. Features and Peripheral List

Peripherals		HT32F52231	HT32F52241	HT32F52331	HT32F52341
Main Flash (KB)		32	63	32	63.5
Option Bytes Flash (KB)		1	1	0.5	0.5
SRAM (KB)		4	8	4	8
Timers	MCTM			1	
	GPTM			1	
	SCTM			4	
	BFTM			2	
	RTC			1	
	WDT			1	
Communication	USB		—		1
	SPI			2	
	USART			1	
	UART			2	
	I ² C			2	
	SCI (ISO7816-3)		—		1
CRC-16/32				1	
EXTI			16		
12-bit ADC			1		
Number of channels		12 Channels			
GPIO		Up to 40		Up to 38	
CPU frequency		Up to 40MHz		Up to 48MHz	
Operating voltage		2.0 V ~ 3.6 V			
Operating temperature		-40°C ~ +85°C			
Package		24/28-pin SSOP 33-pin QFN, 48-pin LQFP		33-pin QFN, 48-pin LQFP	

Block Diagram

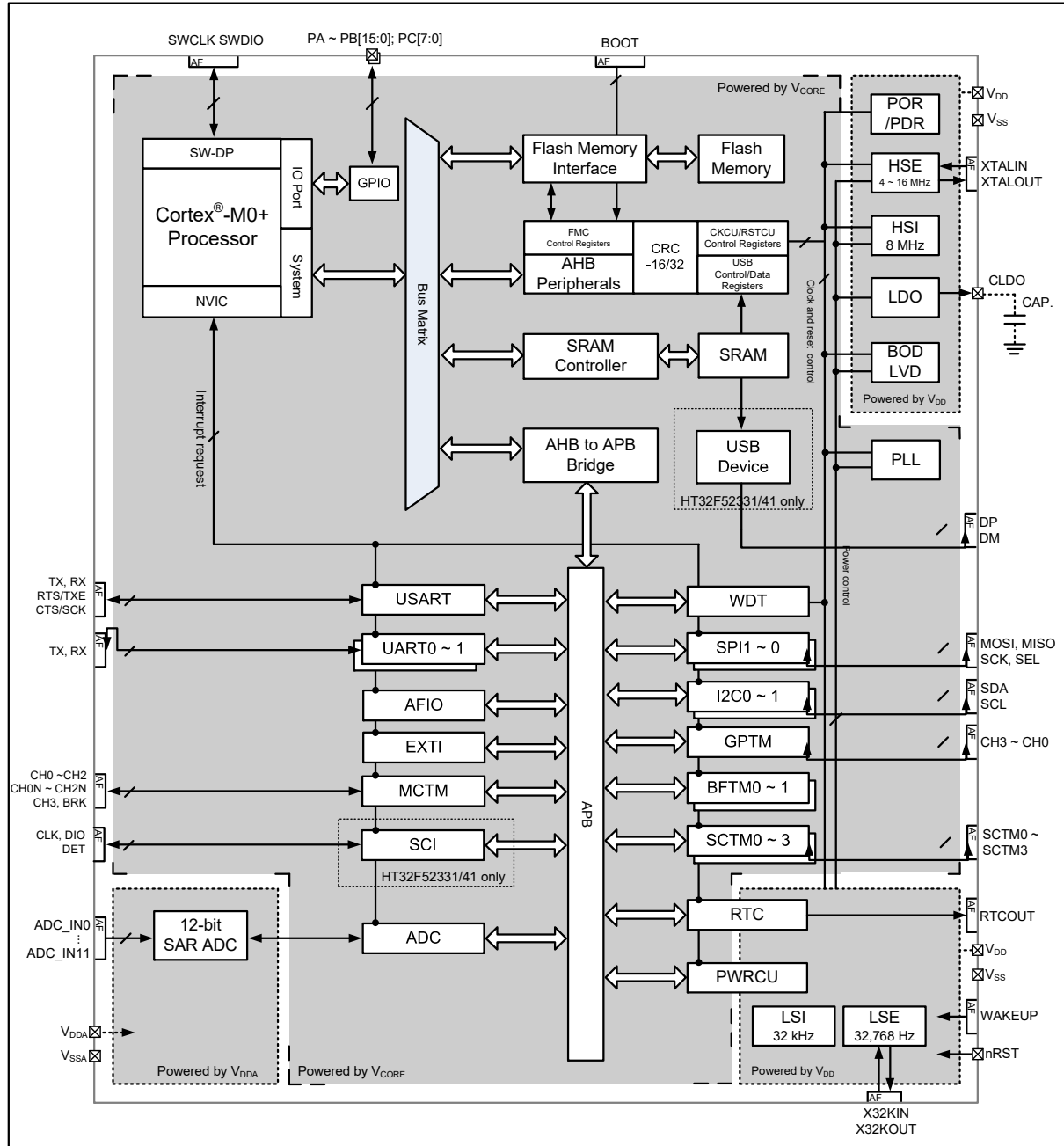

Figure 1. Block Diagram

Memory Map

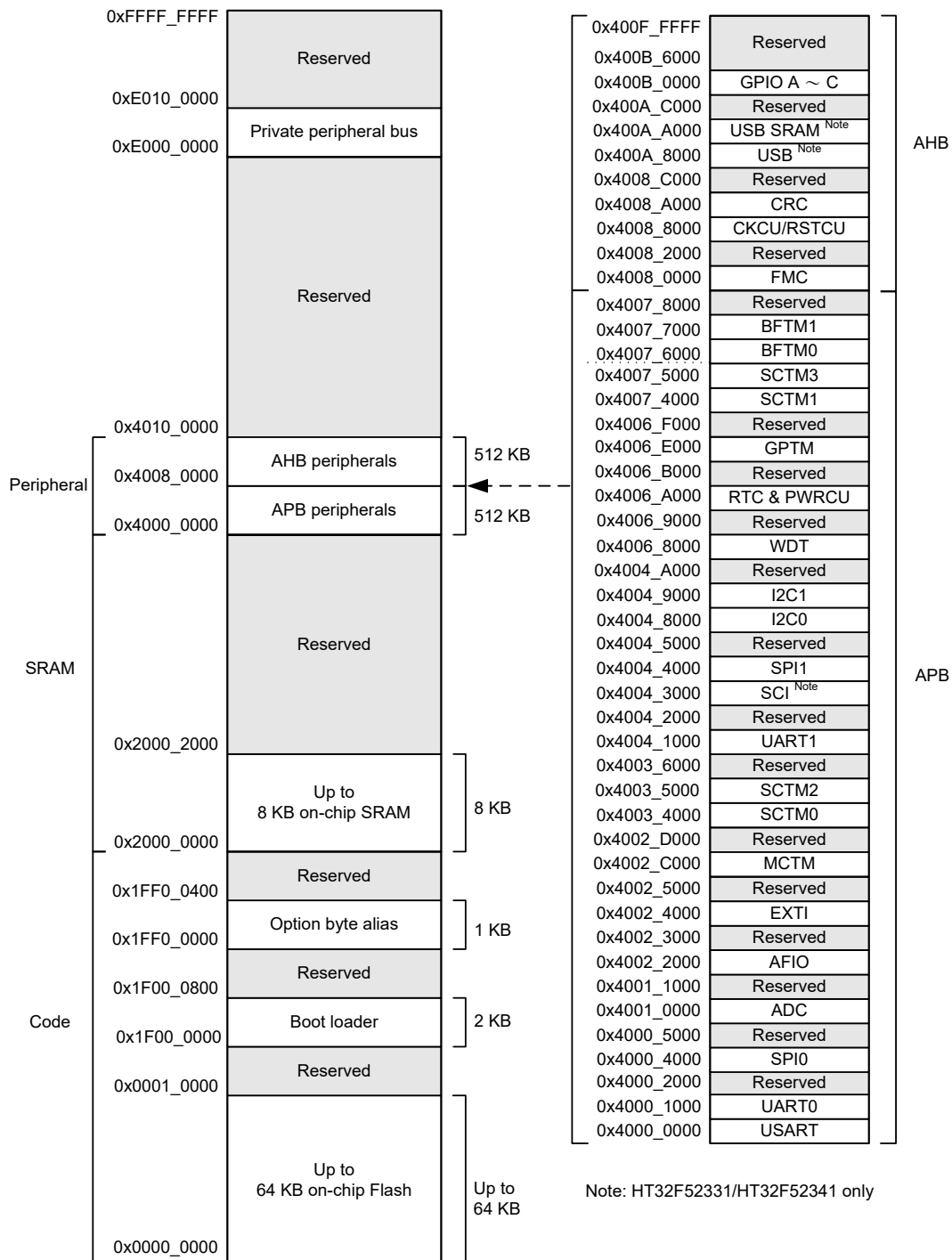

Figure 2. Memory Map

Table 2. Register Map

Start Address	End Address	Peripheral	Bus
0x4000_0000	0x4000_0FFF	USART0	APB
0x4000_1000	0x4000_1FFF	UART0	
0x4000_2000	0x4000_3FFF	Reserved	
0x4000_4000	0x4000_4FFF	SPI0	
0x4000_5000	0x4001_9FFF	Reserved	
0x4001_0000	0x4001_0FFF	ADC	
0x4001_1000	0x4002_1FFF	Reserved	
0x4002_2000	0x4002_2FFF	AFIO	
0x4002_3000	0x4002_3FFF	Reserved	
0x4002_4000	0x4002_4FFF	EXTI	
0x4002_5000	0x4002_BFFF	Reserved	
0x4002_C000	0x4002_CFFF	MCTM	
0x4002_D000	0x4003_3FFF	Reserved	
0x4003_4000	0x4003_4FFF	SCTM0	
0x4003_5000	0x4003_5FFF	SCTM2	
0x4003_6000	0x4004_0FFF	Reserved	
0x4004_1000	0x4004_1FFF	UART1	
0x4004_2000	0x4004_2FFF	Reserved	
0x4004_3000	0x4004_3FFF	SCI ^{Note}	
0x4004_4000	0x4004_4FFF	SPI1	
0x4004_5000	0x4004_7FFF	Reserved	
0x4004_8000	0x4004_8FFF	I2C0	
0x4004_9000	0x4004_9FFF	I2C1	
0x4004_A000	0x4006_7FFF	Reserved	
0x4006_8000	0x4006_8FFF	WDT	
0x4006_9000	0x4006_9FFF	Reserved	
0x4006_A000	0x4006_AFFF	RTC/PWRCU	
0x4006_B000	0x4006_DFFF	Reserved	
0x4006_E000	0x4006_EFFF	GPTM	
0x4006_F000	0x4007_3FFF	Reserved	
0x4007_4000	0x4007_4FFF	SCTM1	
0x4007_5000	0x4007_5FFF	SCTM3	
0x4007_6000	0x4007_6FFF	BFTM0	
0x4007_7000	0x4007_7FFF	BFTM1	
0x4007_8000	0x4007_FFFF	Reserved	

Start Address	End Address	Peripheral	Bus
0x4008_0000	0x4008_1FFF	FMC	AHB
0x4008_2000	0x4008_7FFF	Reserved	
0x4008_8000	0x4008_9FFF	CKCU/RSTCU	
0x4008_A000	0x4008_BFFF	CRC	
0x4008_C000	0x400A_7FFF	Reserved	
0x400A_8000	0x400A_BFFF	USB ^{Note}	
0x400A_C000	0x400A_FFFF	Reserved	
0x400B_0000	0x400B_1FFF	GPIOA	
0x400B_2000	0x400B_3FFF	GPIOB	
0x400B_4000	0x400B_5FFF	GPIOC	
0x400B_6000	0x400F_FFFF	Reserved	

Note: HT32F52331/HT32F52341 only.

Clock Structure

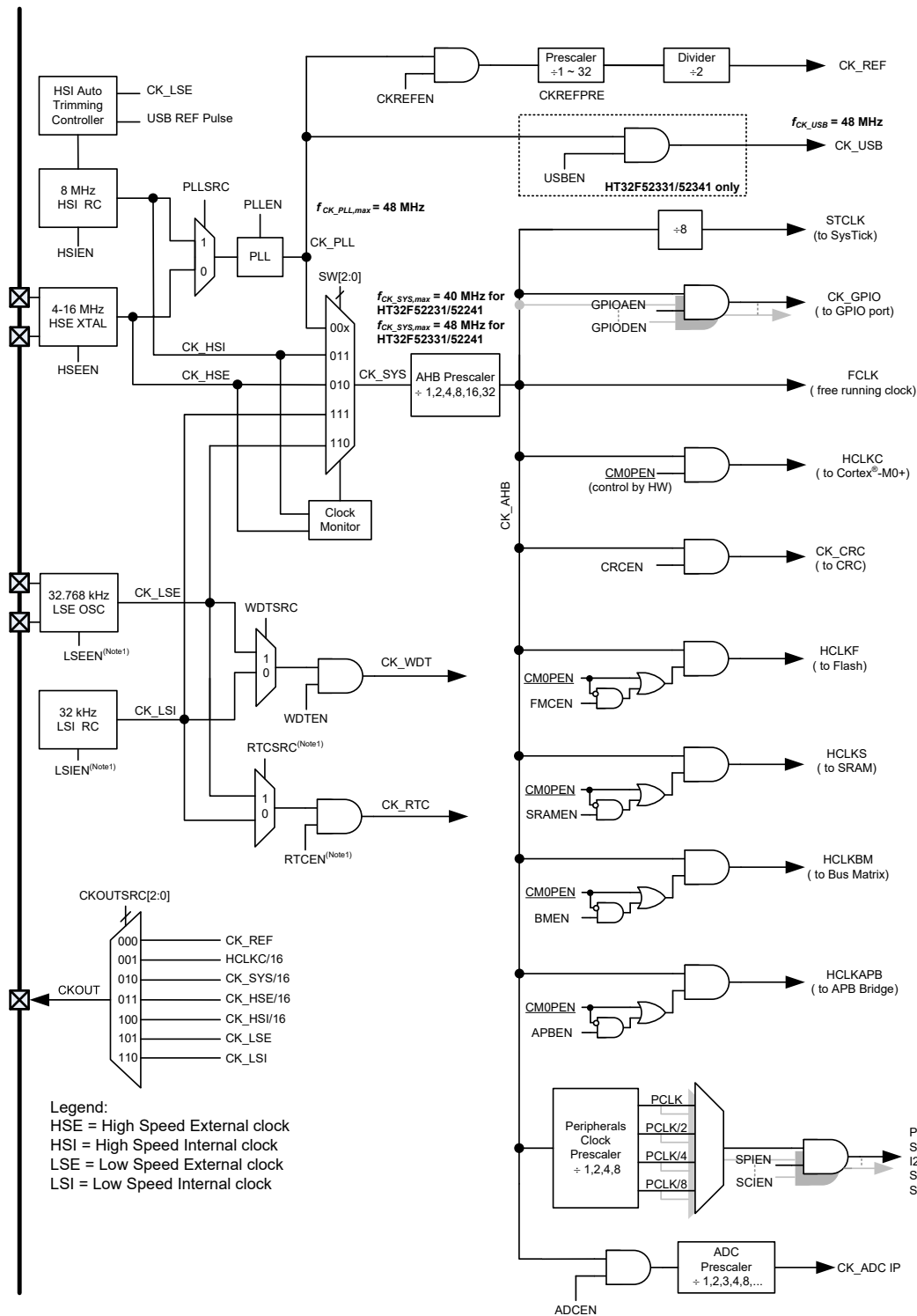

Figure 3. Clock Structure

4 Pin Assignment

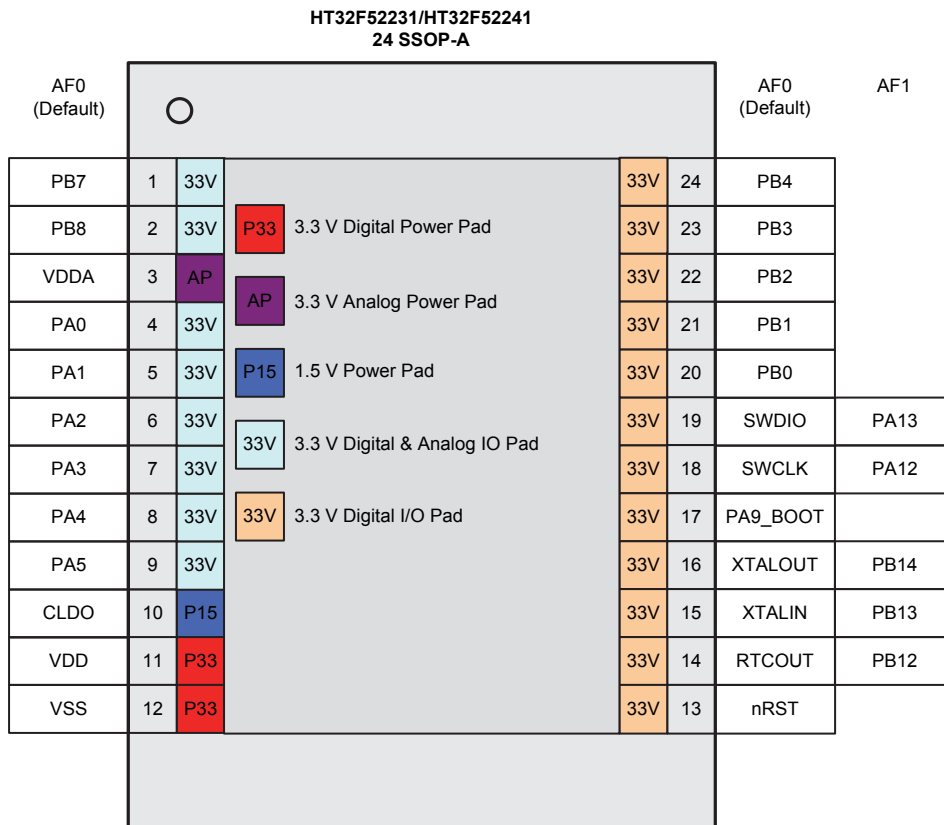
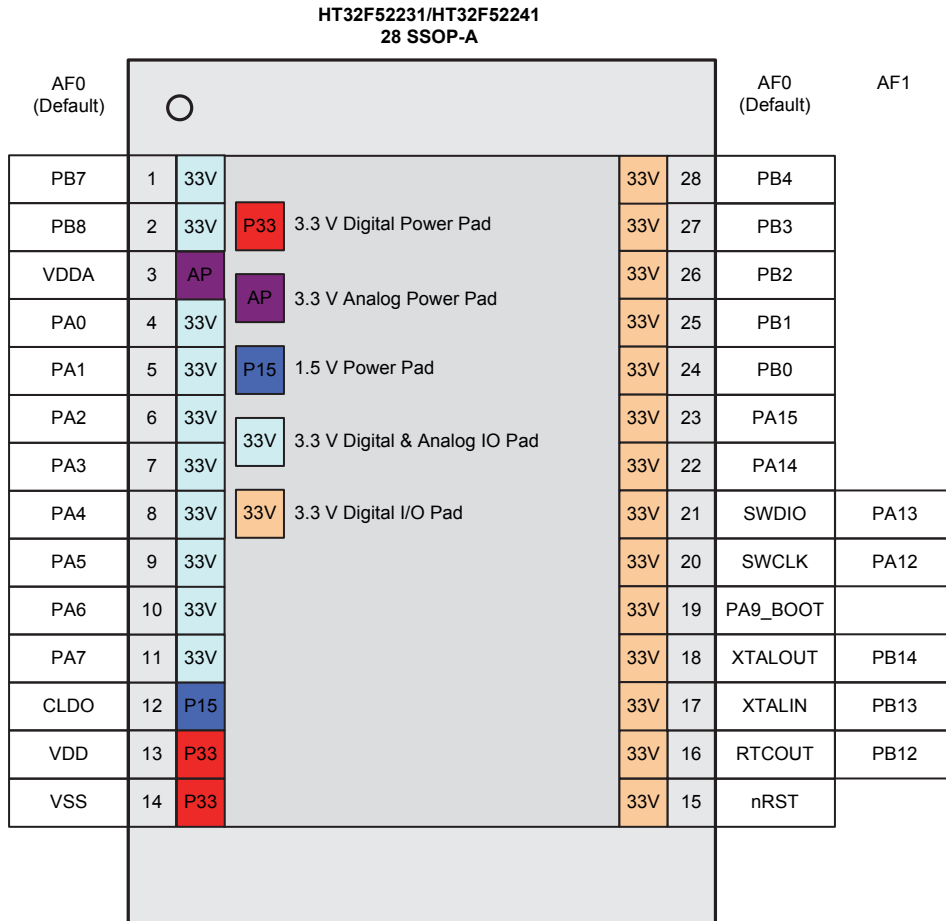

Figure 4. HT32F52231/52241 24-pin SSOP Pin Assignment



4 Pin Assignment

Figure 5. HT32F52231/52241 28-pin SSOP Pin Assignment

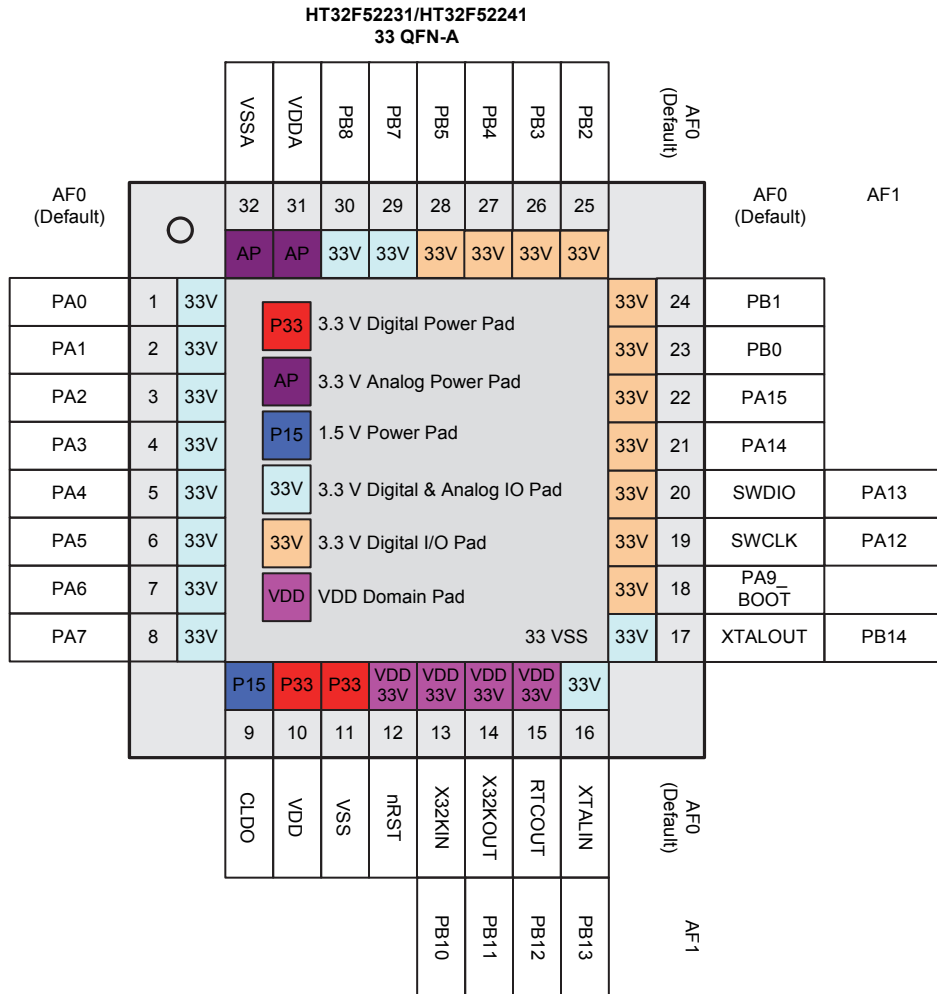
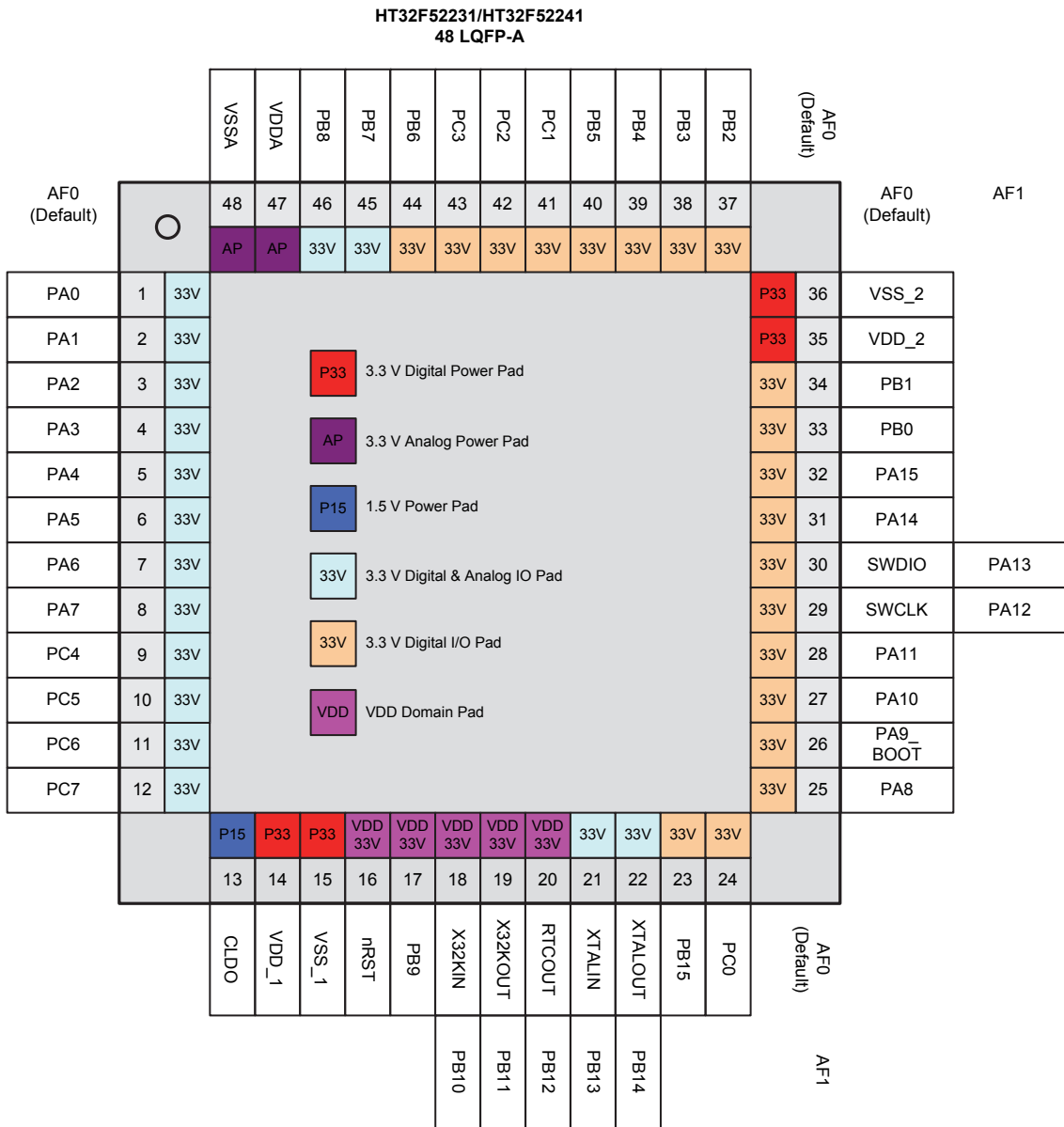
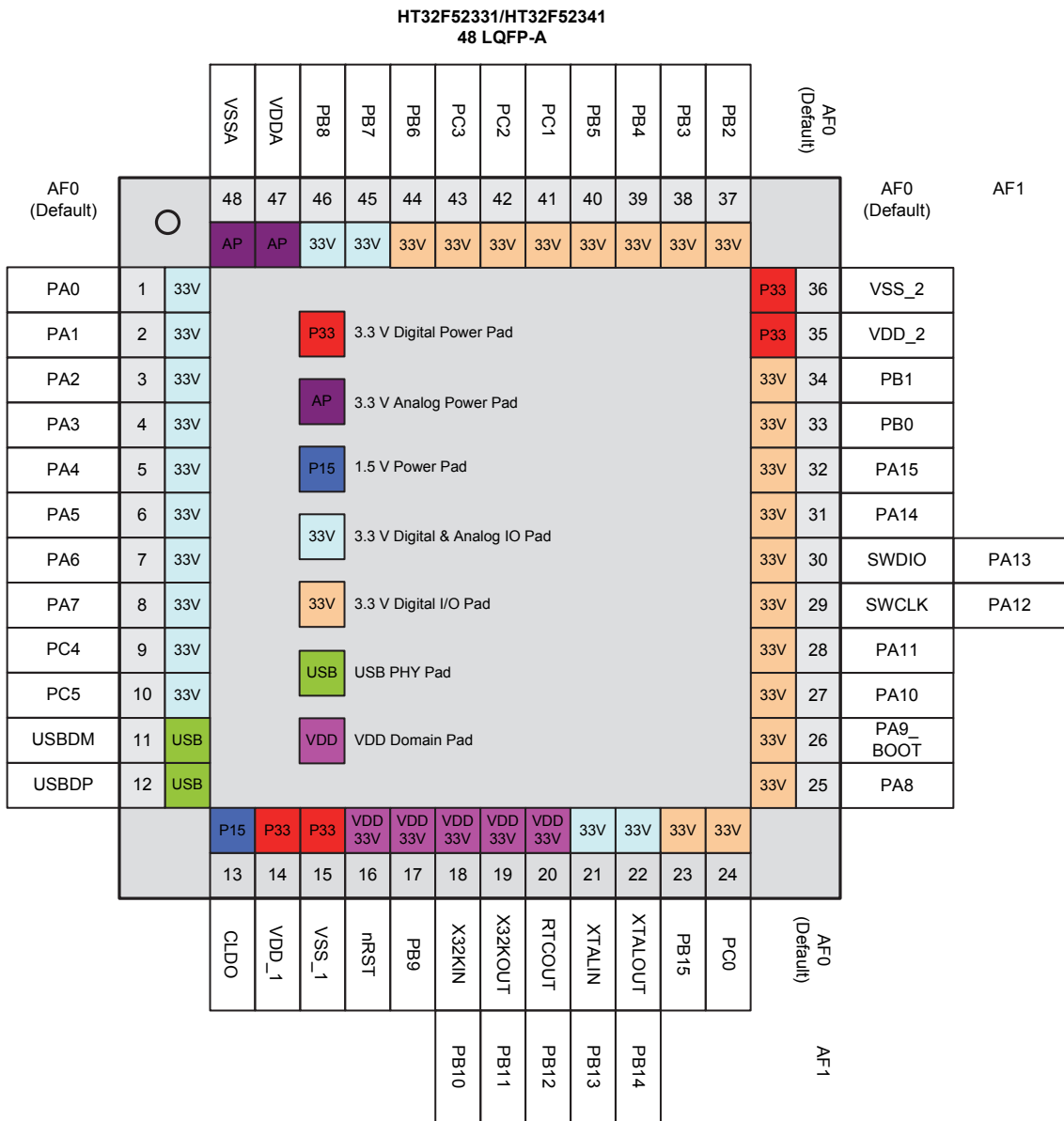

Figure 6. HT32F52231/52241 33-pin QFN Pin Assignment



4 Pin Assignment

Figure 7. HT32F52231/52241 48-pin LQFP Pin Assignment



4 Pin Assignment

Figure 9. HT32F52331/52341 48-pin LQFP Pin Assignment

Table 3. HT32F52231/52241 Series Pin Assignment for 24/28SSOP, 33QFN, 48LQFP Package

Package				HT32F52231/52241 Alternate Function Mapping																
48 LQFP	33 QFN	28 SSOP	24 SSOP	AF0 System Default	AF1 GPIO	AF2 ADC	AF3 N/A	AF4 GPTM /MCTM	AF5 SPI	AF6 USART /UART	AF7 I ² C	AF8 N/A	AF9 N/A	AF10 N/A	AF11 N/A	AF12 N/A	AF13 SCTM	AF14 N/A	AF15 System Other	
1	1	4	4	PA0		ADC_IN2		GT_CH0	SPI1_SCK	USR_RTS	I2C1_SCL									
2	2	5	5	PA1		ADC_IN3		GT_CH1	SPI1_MOSI	USR_CTS	I2C1_SDA									
3	3	6	6	PA2		ADC_IN4		GT_CH2	SPI1_MISO	USR_TX										
4	4	7	7	PA3		ADC_IN5		GT_CH3	SPI1_SEL	USR_RX										
5	5	8	8	PA4		ADC_IN6		GT_CH0	SPI0_SCK	UR1_TX	I2C0_SCL									
6	6	9	9	PA5		ADC_IN7		GT_CH1	SPI0_MOSI	UR1_RX	I2C0_SDA									
7	7	10		PA6		ADC_IN8		GT_CH2	SPI0_MISO											
8	8	11		PA7		ADC_IN9		GT_CH3	SPI0_SEL											
9				PC4		ADC_IN10				USR_TX								SCTM0		
10				PC5		ADC_IN11				USR_RX								SCTM1		
11				PC6				MT_CH2		UR0_TX	I2C0_SCL									
12				PC7				MT_CH2N		UR0_RX	I2C0_SDA									
13	9	12	10	CLDO																
14	10	13	11	VDD_1																
15	11	14	12	VSS_1																
16	12	15	13	nRST																
17				PB9				MT_CH3												
18	13			X32KIN	PB10			GT_CH0	SPI1_SEL	USR_TX								SCTM2		
19	14			X32KOUT	PB11			GT_CH1	SPI1_SCK	USR_RX								SCTM3		
20	15	16	14	RTCOU	PB12				SPI0_MISO	UR0_RX								SCTM0		WAKEUP
21	16	17	15	XTALIN	PB13					UR0_TX	I2C0_SCL									
22	17	18	16	XTALOUT	PB14					UR0_RX	I2C0_SDA									
23				PB15				MT_CH0	SPI0_SEL		I2C1_SCL									
24				PC0				MT_CH0N	SPI0_SCK		I2C1_SDA							SCTM3		
25				PA8						USR_TX								SCTM2		
26	18	19	17	PA9 BOOT					SPI0_MOSI									SCTM3		CKOUT
27				PA10				MT_CH1	SPI0_MOSI	USR_RX										
28				PA11				MT_CH1N	SPI0_MISO									SCTM0		
29	19	20	18	SWCLK	PA12															
30	20	21	19	SWDIO	PA13															
31	21	22		PA14				MT_CH0	SPI1_SEL	USR_RTS	I2C1_SCL									
32	22	23		PA15				MT_CH0N	SPI1_SCK	USR_CTS	I2C1_SDA							SCTM1		
33	23	24	20	PB0				MT_CH1	SPI1_MOSI	USR_TX	I2C0_SCL									
34	24	25	21	PB1				MT_CH1N	SPI1_MISO	USR_RX	I2C0_SDA							SCTM2		
35				VDD_2																
36	33			VSS_2																
37	25	26	22	PB2				MT_CH2	SPI0_SEL	UR1_TX										
38	26	27	23	PB3				MT_CH2N	SPI0_SCK	UR1_RX								SCTM1		
39	27	28	24	PB4				MT_BRK	SPI0_MOSI	UR1_TX								SCTM0		
40	28			PB5				GT_CH2	SPI0_MISO	UR1_RX										
41				PC1				MT_CH0	SPI1_SEL	UR1_TX										
42				PC2				MT_CH0N	SPI1_SCK											
43				PC3				MT_BRK	SPI1_MOSI	UR1_RX										
44				PB6				GT_CH3	SPI1_MISO	UR0_TX										
45	29	1	1	PB7		ADC_IN0		MT_CH1	SPI0_MISO	UR0_TX	I2C1_SCL									
46	30	2	2	PB8		ADC_IN1		MT_CH1N	SPI0_SEL	UR0_RX	I2C1_SDA									
47	31	3	3	VDDA																
48	32			VSSA																

Note: The pin number 33 of the 33-pin QFN package is located at the bottom metal of the QFN package.

Table 4. HT32F52331/52341 Series Pin Assignment for 33QFN, 48LQFP Package

Package		HT32F52331/52341 Alternate Function Mapping															
48 LQFP	33 QFN	AF0 System Default	AF1 GPIO	AF2 ADC	AF3 N/A	AF4 GPTM /MCTM	AF5 SPI	AF6 USART /UART	AF7 I2C	AF8 SCI	AF9 N/A	AF10 N/A	AF11 N/A	AF12 N/A	AF13 SCTM	AF14 N/A	AF15 System Other
1	1	PA0		ADC_IN2		GT_CH0	SPI1_SCK	USR_RTS	I2C1_SCL	SCI_CLK							
2	2	PA1		ADC_IN3		GT_CH1	SPI1_MOSI	USR_CTS	I2C1_SDA	SCI_DIO							
3	3	PA2		ADC_IN4		GT_CH2	SPI1_MISO	USR_TX									
4	4	PA3		ADC_IN5		GT_CH3	SPI1_SEL	USR_RX									
5	5	PA4		ADC_IN6		GT_CH0	SPI0_SCK	UR1_TX	I2C0_SCL	SCI_CLK							
6	6	PA5		ADC_IN7		GT_CH1	SPI0_MOSI	UR1_RX	I2C0_SDA	SCI_DIO							
7		PA6		ADC_IN8		GT_CH2	SPI0_MISO			SCI_DET							
8		PA7		ADC_IN9		GT_CH3	SPI0_SEL										
9		PC4		ADC_IN10				USR_TX								SCTM0	
10		PC5		ADC_IN11				USR_RX								SCTM1	
11	7	USBDM															
12	8	USBDP															
13	9	CLDO															
14	10	VDD_1															
15	11	VSS_1															
16	12	nRST															
17		PB9				MT_CH3											
18	13	X32KIN	PB10			GT_CH0	SPI1_SEL	USR_TX								SCTM2	
19	14	X32KOUT	PB11			GT_CH1	SPI1_SCK	USR_RX								SCTM3	
20	15	RTCOUT	PB12				SPI0_MISO	UR0_RX								SCTM0	WAKEUP
21	16	XTALIN	PB13					UR0_TX	I2C0_SCL								
22	17	XTALOUT	PB14					UR0_RX	I2C0_SDA								
23		PB15				MT_CH0	SPI0_SEL		I2C1_SCL								
24		PC0				MT_CH0N	SPI0_SCK		I2C1_SDA							SCTM3	
25		PA8						USR_TX		SCI_CLK						SCTM2	
26	18	PA9_BOOT					SPI0_MOSI			SCI_DIO						SCTM3	CKOUT
27		PA10				MT_CH1	SPI0_MOSI	USR_RX		SCI_DET							
28		PA11				MT_CH1N	SPI0_MISO			SCI_DET						SCTM0	
29	19	SWCLK	PA12														
30	20	SWDIO	PA13														
31	21	PA14				MT_CH0	SPI1_SEL	USR_RTS	I2C1_SCL	SCI_CLK							
32	22	PA15				MT_CH0N	SPI1_SCK	USR_CTS	I2C1_SDA	SCI_DIO						SCTM1	
33	23	PB0				MT_CH1	SPI1_MOSI	USR_TX	I2C0_SCL								
34	24	PB1				MT_CH1N	SPI1_MISO	USR_RX	I2C0_SDA							SCTM2	
35		VDD_2															
36	33	VSS_2															
37	25	PB2				MT_CH2	SPI0_SEL	UR1_TX									
38	26	PB3				MT_CH2N	SPI0_SCK	UR1_RX								SCTM1	
39	27	PB4				MT_BRK	SPI0_MOSI	UR1_TX								SCTM0	
40	28	PB5				GT_CH2	SPI0_MISO	UR1_RX									
41		PC1				MT_CH0	SPI1_SEL	UR1_TX									
42		PC2				MT_CH0N	SPI1_SCK										
43		PC3				MT_BRK	SPI1_MOSI	UR1_RX									
44		PB6				GT_CH3	SPI1_MISO	UR0_TX		SCI_CLK							
45	29	PB7		ADC_IN0		MT_CH1	SPI0_MISO	UR0_TX	I2C1_SCL	SCI_DET							
46	30	PB8		ADC_IN1		MT_CH1N	SPI0_SEL	UR0_RX	I2C1_SDA	SCI_DIO							
47	31	VDDA															
48	32	VSSA															

Note: The pin number 33 of the 33-pin QFN package is located at the bottom metal of the QFN package.

Table 5. HT32F52231/52241 Pin Description

Pin number				Pin Name	Type (Note1)	IO Structure (Note2)	Output Driving	Description	
48LQFP	33QFN	28SSOP	24SSOP					Default function (AF0)	
1	1	4	4	PA0	AI/O	33V	4/8/12/16 mA	PA0	
2	2	5	5	PA1	AI/O	33V	4/8/12/16 mA	PA1	
3	3	6	6	PA2	AI/O	33V	4/8/12/16 mA	PA2	
4	4	7	7	PA3	AI/O	33V	4/8/12/16 mA	PA3	
5	5	8	8	PA4	AI/O	33V	4/8/12/16 mA	PA4	PA4, this pin provides a UART_TX function in the Boot loader mode
6	6	9	9	PA5	AI/O	33V	4/8/12/16 mA	PA5	PA5, this pin provides a UART_RX function in the Boot loader mode
7		10		PA6	AI/O	33V	4/8/12/16 mA	PA6	
8		11		PA7	AI/O	33V	4/8/12/16 mA	PA7	
9				PC4	AI/O	33V	4/8/12/16 mA	PC4	
10				PC5	AI/O	33V	4/8/12/16 mA	PC5	
11	7			PC6	AI/O	—	—	PC6	
12	8			PC7	AI/O	—	—	PC7	
13	9	12	10	CLDO	P	—	—		Core power LDO 1.5 V output It must be connected a 1 μF capacitor as close as possible between this pin and VSS_1
14	10	13	11	VDD_1	P	—	—		Voltage for digital I/O
15	11	14	12	VSS_1	P	—	—		Ground reference for digital I/O
16	12	15	13	nRST Note 3	I	33V_PU	—		External reset pin and external wakeup pin in the Power-Down mode
17				PB9 Note 3	I/O (V _{DD})	33V	4/8/12/16 mA	PB9	
18	13			PB10 Note 3	AI/O (V _{DD})	33V	4/8/12/16 mA	X32KIN	
19	14			PB11 Note 3	AI/O (V _{DD})	33V	4/8/12/16 mA	X32KOUT	
20	15	16	14	PB12 Note 3	I/O (V _{DD})	33V	4/8/12/16 mA	RTCOUT	
21	16	17	15	PB13	AI/O	33V	4/8/12/16 mA	XTALIN	
22	17	18	16	PB14	AI/O	33V	4/8/12/16 mA	XTALOUT	
23				PB15	I/O	33V	4/8/12/16 mA	PB15	
24				PC0	I/O	33V	4/8/12/16 mA	PC0	
25				PA8	I/O	33V	4/8/12/16 mA	PA8	
26	18	19	17	PA9	I/O	33V_PU	4/8/12/16 mA	PA9_BOOT	
27				PA10	I/O	33V	4/8/12/16 mA	PA10	
28				PA11	I/O	33V	4/8/12/16 mA	PA11	
29	19	20	18	PA12	I/O	33V_PU	4/8/12/16 mA	SWCLK	
30	20	21	19	PA13	I/O	33V_PU	4/8/12/16 mA	SWDIO	
31	21	22		PA14	I/O	33V	4/8/12/16 mA	PA14	
32	22	23		PA15	I/O	33V	4/8/12/16 mA	PA15	
33	23	24	20	PB0	I/O	33V	4/8/12/16 mA	PB0	
34	24	25	21	PB1	I/O	33V	4/8/12/16 mA	PB1	
35				VDD_2	P	—	—		Voltage for digital I/O
36	33			VSS_2	P	—	—		Ground reference for digital I/O
37	25	26	22	PB2	I/O	33V	4/8/12/16 mA	PB2	
38	26	27	23	PB3	I/O	33V	4/8/12/16 mA	PB3	
39	27	28	24	PB4	I/O	33V	4/8/12/16 mA	PB4	
40	28			PB5	I/O	33V	4/8/12/16 mA	PB5	
41				PC1	I/O	33V	4/8/12/16 mA	PC1	
42				PC2	I/O	33V	4/8/12/16 mA	PC2	
43				PC3	I/O	33V	4/8/12/16 mA	PC3	
44				PB6	I/O	33V	4/8/12/16 mA	PB6	
45	29	1	1	PB7	AI/O	33V	4/8/12/16 mA	PB7	
46	30	2	2	PB8	AI/O	33V	4/8/12/16 mA	PB8	
47	31	3	3	VDDA	P	—	—		Analog voltage for ADC and Comparator
48	32			VSSA	P	—	—		Ground reference for the ADC and Comparator

- Note: 1. I = input, O = output, A = Analog port, P = power supply, PU = pull-up, V_{DD} = V_{DD} Power
 2. 33V = 3.3V tolerant.
 3. These pins are located at the V_{DD} power domain.
 4. In the Boot loader mode, only the UART interface can be used for communication.

Table 6. HT32F52331/52341 Pin Description

Pin number		Pin Name	Type (Note1)	IO Structure (Note2)	Output Driving	Description	
48LQFP	33QFN					Default function (AF0)	
1	1	PA0	AI/O	33V	4/8/12/16 mA	PA0	
2	2	PA1	AI/O	33V	4/8/12/16 mA	PA1	
3	3	PA2	AI/O	33V	4/8/12/16 mA	PA2	
4	4	PA3	AI/O	33V	4/8/12/16 mA	PA3	
5	5	PA4	AI/O	33V	4/8/12/16 mA	PA4	PA4, this pin provides a UART_TX function in the Boot loader mode
6	6	PA5	AI/O	33V	4/8/12/16 mA	PA5	PA5, this pin provides a UART_RX function in the Boot loader mode
7		PA6	AI/O	33V	4/8/12/16 mA	PA6	
8		PA7	AI/O	33V	4/8/12/16 mA	PA7	
9		PC4	AI/O	33V	4/8/12/16 mA	PC4	
10		PC5	AI/O	33V	4/8/12/16 mA	PC5	
11	7	USBDM	AI/O	—	—		USB Differential data bus conforming to the Universal Serial Bus standard.
12	8	USBDM	AI/O	—	—		USB Differential data bus conforming to the Universal Serial Bus standard.
13	9	CLDO	P	—	—		Core power LDO 1.5 V output It must be connected a 1 μF capacitor as close as possible between this pin and VSS_1
14	10	VDD_1	P	—	—		Voltage for digital I/O
15	11	VSS_1	P	—	—		Ground reference for digital I/O
16	12	nRST ^{Note 3}	I	33V_PU	--		External reset pin and external wakeup pin in the Power-Down mode
17		PB9 ^{Note 3}	I/O (V _{DD})	33V	4/8/12/16 mA	PB9	
18	13	PB10 ^{Note 3}	AI/O (V _{DD})	33V	4/8/12/16 mA	X32KIN	
19	14	PB11 ^{Note 3}	AI/O (V _{DD})	33V	4/8/12/16 mA	X32KOUT	
20	15	PB12 ^{Note 3}	I/O (V _{DD})	33V	4/8/12/16 mA	RTCOUT	
21	16	PB13	AI/O	33V	4/8/12/16 mA	XTALIN	
22	17	PB14	AI/O	33V	4/8/12/16 mA	XTALOUT	
23		PB15	I/O	33V	4/8/12/16 mA	PB15	
24		PC0	I/O	33V	4/8/12/16 mA	PC0	
25		PA8	I/O	33V	4/8/12/16 mA	PA8	
26	18	PA9	I/O	33V_PU	4/8/12/16 mA	PA9_BOOT	
27		PA10	I/O	33V	4/8/12/16 mA	PA10	
28		PA11	I/O	33V	4/8/12/16 mA	PA11	
29	19	PA12	I/O	33V_PU	4/8/12/16 mA	SWCLK	
30	20	PA13	I/O	33V_PU	4/8/12/16 mA	SWDIO	
31	21	PA14	I/O	33V	4/8/12/16 mA	PA14	
32	22	PA15	I/O	33V	4/8/12/16 mA	PA15	
33	23	PB0	I/O	33V	4/8/12/16 mA	PB0	
34	24	PB1	I/O	33V	4/8/12/16 mA	PB1	
35		VDD_2	P	—	—		Voltage for digital I/O
36	33	VSS_2	P	—	—		Ground reference for digital I/O
37	25	PB2	I/O	33V	4/8/12/16 mA	PB2	
38	26	PB3	I/O	33V	4/8/12/16 mA	PB3	
39	27	PB4	I/O	33V	4/8/12/16 mA	PB4	
40	28	PB5	I/O	33V	4/8/12/16 mA	PB5	
41		PC1	I/O	33V	4/8/12/16 mA	PC1	
42		PC2	I/O	33V	4/8/12/16 mA	PC2	
43		PC3	I/O	33V	4/8/12/16 mA	PC3	
44		PB6	I/O	33V	4/8/12/16 mA	PB6	
45	29	PB7	AI/O	33V	4/8/12/16 mA	PB7	
46	30	PB8	AI/O	33V	4/8/12/16 mA	PB8	
47	31	VDDA	P	—	—		Analog voltage for ADC and Comparator
48	32	VSSA	P	—	—		Ground reference for the ADC and Comparator

Note: 1. I = input, O = output, A = Analog port, P = power supply, PU = pull-up, V_{DD} = V_{DD} Power
 2. 33V = 3.3V tolerant.
 3. These pins are located at the V_{DD} power domain.
 4. In the Boot loader mode, the UART and USB interfaces are available for communication.

5 Electrical Characteristics

Absolute Maximum Ratings

The following table shows the absolute maximum ratings of the device. These are stress ratings only. Stresses beyond absolute maximum ratings may cause permanent damage to the device. Note that the device is not guaranteed to operate properly at the maximum ratings. Exposure to the absolute maximum rating conditions for extended periods may affect device reliability.

Table 7. Absolute Maximum Ratings

Symbol	Parameter	Min	Max	Unit
V _{DD}	External Main Supply Voltage	V _{SS} - 0.3	V _{SS} + 3.6	V
V _{DDA}	External Analog Supply Voltage	V _{SSA} - 0.3	V _{SSA} + 3.6	V
V _{IN}	Input Voltage on I/O	V _{SS} - 0.3	V _{DD} + 0.3	V
T _A	Ambient Operating Temperature Range	-40	+85	°C
T _{STG}	Storage Temperature Range	-60	+150	°C
T _J	Maximum Junction Temperature	—	+125	°C
P _D	Total Power Dissipation	—	500	mW
V _{ESD}	Electrostatic Discharge Voltage – Human Body Mode	-4000	+4000	V

Recommended DC Operating Conditions

Table 8. Recommended DC Operating Conditions

T_A = 25 °C, unless otherwise specified.

Symbol	Parameter	Conditions	Min	Typ	Max	Unit
V _{DD}	I/O OPERating Voltage	—	2.0	3.3	3.6	V
V _{DDA}	Analog Operating Voltage	—	2.5	3.3	3.6	V

On-Chip LDO Voltage Regulator Characteristics

Table 9. LDO Characteristics

T_A = 25 °C, unless otherwise specified.

Symbol	Parameter	Conditions	Min	Typ	Max	Unit
V _{LDO}	Internal Regulator Output Voltage	V _{DD} ≥ 2.0V Regulator input @ I _{LDO} = 35mA and voltage variant = ±5%, After trimming.	1.425	1.5	1.57	V
I _{LDO}	Output Current	V _{DD} = 2.0V Regulator input @ V _{LDO} = 1.5V	—	30	35	mA
C _{LDO}	External Filter Capacitor Value For Internal Core Power Supply	The capacitor value is dependent on the core power current consumption	—	1	—	μF

Power Consumption

Table 10. HT32F52231/52241 Power Consumption Characteristics

Symbol	Parameter	Conditions	Typ	Max		Unit
			T _A = 25 °C	T _A = 25 °C	T _A = 85 °C	
I _{DD}	Supply Current (Run Mode)	V _{DD} = 3.3 V, HSI = 8 MHz, PLL = 40 MHz, f _{CPU} = 40 MHz, f _{BUS} = 40 MHz, all peripherals enabled	10.8	12.4	—	mA
		V _{DD} = 3.3 V, HSI = 8 MHz, PLL = 40 MHz, f _{CPU} = 40 MHz, f _{BUS} = 40 MHz, all peripherals disabled	6.0	6.9	—	
		V _{DD} = 3.3 V, HSI off, PLL off, LSI on, f _{CPU} = 32 kHz, f _{BUS} = 32 kHz, all peripherals enabled	45	60	—	μA
		V _{DD} = 3.3 V, HSI off, PLL off, LSI on, f _{CPU} = 32 kHz, f _{BUS} = 32 kHz, all peripherals disabled	40	53	—	
	Supply Current (Sleep Mode)	V _{DD} = 3.3 V, HSI = 8 MHz, PLL = 40 MHz, f _{CPU} = 0 MHz, f _{BUS} = 40 MHz, all peripherals enabled	6.5	7.5	—	mA
		V _{DD} = 3.3 V, HSI = 8 MHz, PLL = 40 MHz, f _{CPU} = 0 MHz, f _{BUS} = 40 MHz, all peripherals disabled	1.5	1.7	—	
	Supply Current (Deep-Sleep1 Mode)	V _{DD} = 3.3 V, All clock off (HSE / HSI / PLL / LSE), LDO in low power mode, LSI on, RTC on	32.4	49.6	—	μA
	Supply Current (Deep-Sleep2 Mode)	V _{DD} = 3.3 V, All clock off (HSE / HSI / PLL / LSE), LDO off, DMOS on, LSI on, RTC on	4.4	9	—	
	Supply Current (Power-Down Mode)	V _{DD} = 3.3 V, LDO off, DMOS off, LSE off, LSI on, RTC on	1.40	2.2	—	
		V _{DD} = 3.3 V, LDO off, DOMS off, LSE off, LSI on, RTC off	1.35	2.1	—	

Table 11. HT32F52331/52341 Power Consumption Characteristics

Symbol	Parameter	Conditions	Typ	Max		Unit
			T _A = 25 °C	T _A = 25 °C	T _A = 85 °C	
I _{DD}	Supply Current (Run Mode)	V _{DD} = 3.3 V, HSI = 8 MHz, PLL = 48 MHz, f _{CPU} = 48 MHz, f _{BUS} = 48 MHz, all peripherals enabled	15.1	17.3	—	mA
		V _{DD} = 3.3 V, HSI = 8 MHz, PLL = 48 MHz, f _{CPU} = 48 MHz, f _{BUS} = 48 MHz, all peripherals disabled	7.9	9.0	—	
		V _{DD} = 3.3 V, HSI off, PLL off, LSI on, f _{CPU} = 32 kHz, f _{BUS} = 32 kHz, all peripherals enabled	45	60	—	μA
		V _{DD} = 3.3 V, HSI off, PLL off, LSI on, f _{CPU} = 32 kHz, f _{BUS} = 32 kHz, all peripherals disabled	40	53	—	
	Supply Current (Sleep Mode)	V _{DD} = 3.3 V, HSI = 8 MHz, PLL = 48 MHz, f _{CPU} = 0 MHz, f _{BUS} = 48 MHz, all peripherals enabled	9.3	10.6	—	mA
		V _{DD} = 3.3 V, HSI = 8 MHz, PLL = 48 MHz, f _{CPU} = 0 MHz, f _{BUS} = 48 MHz, all peripherals disabled	1.8	2.0	—	
	Supply Current (Deep-Sleep1 Mode)	V _{DD} = 3.3 V, All clock off (HSE / HSI / PLL / LSE), LDO in low power mode, LSI on, RTC on	32.8	50.2	—	μA
	Supply current (Deep-Sleep2 Mode)	V _{DD} = 3.3 V, All clock off (HSE / HSI / PLL / LSE), LDO off, DMOS on, LSI on, RTC on	4	6.8	—	
	Supply Current (Power-Down Mode)	V _{DD} = 3.3 V, LDO off, DMOS off, LSE off, LSI on, RTC on	1.40	2.2	—	
		V _{DD} = 3.3 V, LDO off, DOMS off, LSE off, LSI on, RTC off	1.36	2.1	—	

- Note: 1. HSE means high speed external oscillator. HSI means 8 MHz high speed internal oscillator.
 2. LSE means 32.768 kHz low speed external oscillator. LSI means 32 kHz low speed internal oscillator.
 3. RTC means real time clock.
 4. Code = while (1) { 208 NOP } executed in Flash.
 5. f_{BUS} means f_{HCLK} and f_{PLK}.

Reset and Supply Monitor Characteristics

Table 12. V_{DD} Power Reset Characteristics

T_A = 25 °C, unless otherwise specified.

Symbol	Parameter	Conditions	Min	Typ	Max	Unit
V _{POR}	Power on Reset Threshold (Rising Voltage on V _{DD})	T _A = -40 °C ~ +85 °C	1.66	1.79	1.90	V
V _{PDR}	Power down Reset Threshold (Falling Voltage on V _{DD})		1.49	1.64	1.78	V
V _{PORHYST}	POR Hysteresis	—	—	150	—	mV
t _{POR}	Reset Delay Time	V _{DD} = 3.3 V	—	0.1	0.2	ms

- Note: 1. Data based on characterization results only, not tested in production.
 2. If the LDO is turned on, the V_{DD} POR has to be in the de-assertion condition. When the V_{DD} POR is in the assertion state then the LDO will be turned off.

Table 13. LVD/BOD Characteristics

T_A = 25 °C, unless otherwise specified.

Symbol	Parameter	Conditions	Min	Typ	Max	Unit	
V _{BOD}	Voltage of Brown Out Detection	After factory-trimmed (V _{DD} Falling edge)	2.02	2.1	2.18	V	
V _{LVD}	Voltage of Low Voltage Detection	V _{DD} Falling edge	LVDS = 000	2.17	2.25	2.33	V
			LVDS = 001	2.32	2.4	2.48	V
			LVDS = 010	2.47	2.55	2.63	V
			LVDS = 011	2.62	2.7	2.78	V
			LVDS = 100	2.77	2.85	2.93	V
			LVDS = 101	2.92	3.0	3.08	V
			LVDS = 110	3.07	3.15	3.23	V
		LVDS = 111	3.22	3.3	3.38	V	
V _{LVDHTST}	LVD Hysteresis	V _{DD} = 3.3 V	—	—	100	mV	
t _{suLVD}	LVD Setup Time	V _{DD} = 3.3 V	—	—	—	5 μs	
t _{aiLVD}	LVD Active Delay Time	V _{DD} = 3.3 V	—	—	—	μs	
I _{DDLVD}	Operation Current ⁽³⁾	V _{DD} = 3.3 V	—	—	5	15 μA	

- Note: 1. Data based on characterization results only, not tested in production.
 2. Bandgap current is not included.
 3. LVDS field is in the PWRCU LVDCSR register.

External Clock Characteristics

Table 14. High Speed External Clock (HSE) Characteristics

T_A = 25 °C, unless otherwise specified.

Symbol	Parameter	Conditions	Min	Typ	Max	Unit
V _{DD}	Operation Range	—	2.0	—	3.6	V
f _{HSE}	High Speed External Oscillator Frequency (HSE)	—	4	—	16	MHz
C _{LHSE}	Load capacitance	V _{DD} = 3.3 V, R _{ESR} = 100 Ω @ 16 MHz	—	—	22	pF
R _{FHSE}	Internal Feedback Resistor between XTALIN and XTALOUT pins	—	—	1	—	MΩ
R _{ESR}	Equivalent Series Resistance*	V _{DD} = 3.3 V, C _L = 12 pF @ 16 MHz, HSEDR = 0 V _{DD} = 2.4 V, C _L = 12 pF @ 16 MHz, HSEDR = 1	—	—	160	Ω
D _{HSE}	HSE Oscillator Duty Cycle	—	40	—	60	%
I _{DDHSE}	HSE Oscillator Current Consumption	V _{DD} = 3.3 V @ 16 MHz	—	TBD	—	mA
I _{PWDHSE}	HSE Oscillator Power Down Current	V _{DD} = 3.3 V	—	—	0.01	μA
t _{SUHSE}	HSE Oscillator SStartup Time	V _{DD} = 3.3 V	—	—	4	ms

Table 15. Low Speed External Clock (LSE) Characteristics

T_A = 25 °C, unless otherwise specified.

Symbol	Parameter	Conditions	Min	Typ	Max	Unit
V _{DD}	Operation Range	—	2.0	—	3.6	V
f _{CK_LSE}	LSE Frequency	V _{DD} = 2.0 V ~ 3.6 V	—	32.768	—	kHz
R _F	Internal Feedback Resistor	—	—	10	—	MΩ
R _{ESR}	Equivalent Series Resistance	V _{DD} = 3.3 V	30	—	TBD	kΩ
C _L	Recommended Load Capacitances	V _{DD} = 3.3 V	6	—	TBD	pF
I _{DDLSE}	Oscillator Supply Current (High Current Mode)	f _{CK_LSE} = 32.768 kHz, R _{ESR} = 50 kΩ, C _L ≥ 7 pF, V _{DD} = 2.0 V ~ 2.7 V T _A = -40 °C ~ +85 °C	—	3.3	6.3	μA
	Oscillator Supply Current (Low Current Mode)	f _{CK_LSE} = 32.768 kHz, R _{ESR} = 50 kΩ, C _L < 7 pF, V _{DD} = 2.0 V ~ 3.6 V T _A = -40 °C ~ +85 °C	—	1.8	3.3	μA
	Power Down Current	—	—	—	0.01	μA
t _{SULSE}	Startup Time (Low Current Mode)	f _{CK_LSI} = 32.768 kHz, V _{DD} = 2.0 V ~ 3.6 V	500	—	—	ms

Note: The following guidelines are recommended to increase the stability of the crystal circuit of the HSE / LSE clock in the PCB layout:

1. The crystal oscillator should be located as close as possible to the MCU to keep the trace lengths as short as possible to reduce any parasitic capacitance.
2. Shield lines in the vicinity of the crystal by using a ground plane to isolate signals and reduce noise.
3. Keep any high frequency signal lines away from the crystal area to prevent any crosstalk adverse effects.

Internal Clock Characteristics

Table 16. High Speed Internal Clock (HSI) Characteristics

T_A = 25 °C, unless otherwise specified.

Symbol	Parameter	Conditions	Min	Typ	Max	Unit
V _{DD}	Operation Range	—	2.0	—	3.6	V
f _{HSI}	HSI Frequency	V _{DD} = 3.3 V @ 25 °C	—	8	—	MHz
ACC _{HSI}	Factory Calibrated HSI Oscillator Frequency Accuracy	V _{DD} = 3.3 V, T _A = 25 °C	-2	—	2	%
		V _{DD} = 2.5 V ~ 3.6 V, T _A = -40 °C ~ +85 °C	-3	—	3	%
		V _{DD} = 2.0 V ~ 3.6 V, T _A = -40 °C ~ +85 °C	-4	—	4	%
Duty	Duty Cycle	f _{HSI} = 8 MHz	35	—	65	%
I _{DDHSI}	Oscillator Supply Current	f _{HSI} = 8 MHz	—	300	500	μA
	Power down Current		—	—	0.05	μA
t _{suHSI}	Startup Time	f _{HSI} = 8 MHz	—	—	10	μs

Table 17. Low Speed Internal Clock (LSI) Characteristics

T_A = 25 °C, unless otherwise specified.

Symbol	Parameter	Conditions	Min	Typ	Max	Unit
f _{LSI}	Low Speed Internal Oscillator Frequency (LSI)	V _{DD} = 3.3 V, T _A = -40 °C ~ +85 °C	21	32	43	kHz
ACC _{LSI}	LSI Frequency Accuracy	After factory-trimmed, V _{DD} = 3.3 V, T _A = 25 °C	-10	—	+10	%
I _{DDL}	LSI Oscillator Operating Current	V _{DD} = 3.3 V, T _A = 25 °C	—	0.4	0.8	μA
t _{SULSI}	LSI Oscillator Startup Time	V _{DD} = 3.3 V, T _A = 25 °C	—	—	100	μs

PLL Characteristics

Table 18. PLL Characteristics

T_A = 25 °C, unless otherwise specified.

Symbol	Parameter	Conditions	Min	Typ	Max	Unit
f _{PLLIN}	PLL Input Clock	—	4	—	16	MHz
f _{CK_PLL}	PLL Output Clock	—	16	—	48	MHz
t _{LOCK}	PLL Lock Time	—	—	200	—	μs

Memory Characteristics

Table 19. Flash Memory Characteristics

T_A = 25 °C, unless otherwise specified.

Symbol	Parameter	Conditions	Min	Typ	Max	Unit
N _{ENDU}	Number of Guaranteed Program / Erase Cycles Before Failure. (Endurance)	T _A = -40 °C ~ +85 °C	20	—	—	K cycles
t _{RET}	Data Retention Time	T _A = -40 °C ~ +85 °C	10	—	—	Years
t _{PROG}	Word Programming Time	T _A = -40 °C ~ +85 °C	20	—	—	μs
t _{ERASE}	Page Erase Time	T _A = -40 °C ~ +85 °C	2	—	—	ms
t _{MERASE}	Mass Erase Time	T _A = -40 °C ~ +85 °C	10	—	—	ms

I/O Port Characteristics

Table 20. I/O Port Characteristics

T_A = 25 °C, unless otherwise specified.

Symbol	Parameter	Conditions	Min	Typ	Max	Unit	
I _{IL}	Low Level Input Current	3.3V IO	V _I = V _{SS} , On-chip pull-up resistor disabled.	—	—	3	μA
		Reset pin		—	—	3	μA
I _{IH}	High Level Input Current	3.3V IO	V _I = V _{DD} , On-chip pull-down resistor disabled.	—	—	3	μA
		Reset pin		—	—	3	μA
V _{IL}	Low Level Input Voltage	3.3V IO	- 0.5	—	V _{DD} × 0.35	V	
		Reset pin	- 0.5	—	V _{DD} × 0.35	V	
V _{IH}	High Level Input Voltage	3.3V IO	V _{DD} × 0.65	—	V _{DD} + 0.5	V	
		Reset pin	V _{DD} × 0.65	—	V _{DD} + 0.5	V	
V _{HYS}	Schmitt Trigger Input Voltage Hysteresis	3.3V IO	—	V _{DD} × 0.12	—	mV	
		Reset pin	—	V _{DD} × 0.12	—	mV	
I _{OL}	Low Level Output Current (GPIO Sink Current)	3.3V IO 4 mA drive, V _{OL} = 0.4 V	4	—	—	mA	
		3.3V IO 8 mA drive, V _{OL} = 0.4 V	8	—	—	mA	
		3.3V IO 12 mA drive, V _{OL} = 0.4 V	12	—	—	mA	
		3.3V IO 16 mA drive, V _{OL} = 0.4 V	16	—	—	mA	
I _{OH}	High Level Output Current (GPIO Source Current)	3.3V I/O 4 mA drive, V _{OH} = V _{DD} - 0.4 V	4	—	—	mA	
		3.3V I/O 8 mA drive, V _{OH} = V _{DD} - 0.4 V	8	—	—	mA	
		3.3V I/O 12 mA drive, V _{OH} = V _{DD} - 0.4 V	12	—	—	mA	
		3.3V I/O 16 mA drive, V _{OH} = V _{DD} - 0.4 V	16	—	—	mA	
V _{OL}	Low Level Output Voltage	3.3V 4 mA drive IO, I _{OL} = 4 mA	—	—	0.4	V	
		3.3V 8 mA drive IO, I _{OL} = 8 mA	—	—	0.4	V	
		3.3V 12 mA drive IO, I _{OL} = 12 mA	—	—	0.4	V	
		3.3V 16 mA drive IO, I _{OL} = 16 mA	—	—	0.4	V	
V _{OH}	High Level Output Voltage	3.3V 4 mA drive IO, I _{OH} = 4 mA	V _{DD} - 0.4	—	—	V	
		3.3V 8 mA drive IO, I _{OH} = 8 mA	V _{DD} - 0.4	—	—	V	
		3.3V 12 mA drive IO, I _{OH} = 12 mA	V _{DD} - 0.4	—	—	V	
		3.3V 16 mA drive IO, I _{OH} = 16 mA	V _{DD} - 0.4	—	—	V	
R _{PU}	Internal Pull-up Resistor	3.3V I/O	—	46	—	kΩ	
R _{PD}	Internal Pull-down Resistor	3.3V I/O	—	46	—	kΩ	

ADC Characteristics

Table 21. ADC Characteristics

T_A = 25 °C, unless otherwise specified.

Symbol	Parameter	Conditions	Min	Typ	Max	Unit
V _{DDA}	Operating Voltage	—	2.5	3.3	3.6	V
V _{ADCIN}	A/D Converter Input Voltage Range	—	0	—	V _{REF+}	V
V _{REF+}	A/D Converter Reference Voltage	—	—	V _{DDA}	V _{DDA}	V
I _{ADC}	Current Consumption	V _{DDA} = 3.3 V	—	1	TBD	mA
I _{ADC_DN}	Power Down Current Consumption	V _{DDA} = 3.3 V	—	—	0.1	μA
f _{ADC}	A/D Converter Clock	—	0.7	—	16	MHz
f _s	Sampling Rate	—	0.05	—	1	MHz
t _{DL}	Data Latency	—	—	12.5	—	1/f _{ADC} Cycles
t _{S&H}	Sampling & Hold Time	—	—	3.5	—	1/f _{ADC} Cycles
t _{ADCCONV}	A/D Converter Conversion Time	ADST [7 : 0] = 2	—	16	—	1/f _{ADC} Cycles
R _I	Input Sampling Switch Resistance	—	—	—	1	kΩ
C _I	Input Sampling Capacitance	No pin/pad capacitance included	—	16	—	pF
t _{SU}	Startup Time	—	—	—	1	μs
N	Resolution	—	—	12	—	bits
INL	Integral Non-linearity Error	f _s = 750 kHz, V _{DDA} = 3.3 V	—	±2	±5	LSB
DNL	Differential Non-linearity Error	f _s = 750 kHz, V _{DDA} = 3.3 V	—	±1	—	LSB
E _O	Offset Error	—	—	—	±10	LSB
E _G	Gain Error	—	—	—	±10	LSB

Note: 1. Data based on characterization results only, not tested in production.

2. Due to the A/D Converter input channel and GPIO pin-shared function design limitation, the V_{DDA} supply power of the A/D Converter has to be equal to the V_{DD} supply power of the MCU in the application circuit.
3. The figure below shows the equivalent circuit of the A/D Converter Sample-and-Hold input stage where C_I is the storage capacitor, R_I is the resistance of the sampling switch and R_S is the output impedance of the signal source V_S. Normally the sampling phase duration is approximately, 3.5/f_{ADC}. The capacitance, C_I, must be charged within this time frame and it must be ensured that the voltage at its terminals becomes sufficiently close to V_S for accuracy. To guarantee this, R_S is not allowed to have an arbitrarily large value.

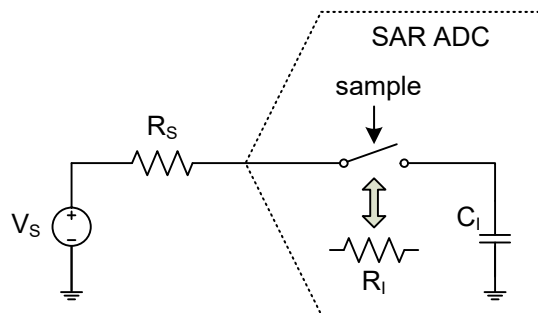

Figure 10. ADC Sampling Network Model

The worst case occurs when the extremities of the input range (0V and V_{REF}) are sampled consecutively. In this situation a sampling error below $\frac{1}{4}$ LSB is ensured by using the following equation:

$$R_s < \frac{3.5}{f_{ADC} C_1 \ln(2^{N+2})} - R_i$$

Where f_{ADC} is the ADC clock frequency and N is the ADC resolution (N = 12 in this case). A safe margin should be considered due to the pin/pad parasitic capacitances, which are not accounted for in this simple model.

If, in a system where the A/D Converter is used, there are no rail-to-rail input voltage variations between consecutive sampling phases, R_s may be larger than the value indicated by the equation above.

SCTM/GPTM/MCTM Characteristics

Table 22. SCTM/GPTM/MCTM Characteristics

Symbol	Parameter	Conditions	Min	Typ	Max	Unit
f_{TM}	Timer Clock Source for GPTM and MCTM	—	—	—	48	MHz
t_{RES}	Timer Resolution Time	—	1	—	—	f_{TM}
f_{EXT}	External Single Frequency on Channel 1 ~ 4	—	—	—	1/2	f_{TM}
RES	Timer Resolution	—	—	—	16	bits

I²C Characteristics

Table 23. I²C Characteristics

Symbol	Parameter	Standard mode		Fast mode		Fast mode plus		Unit
		Min	Max	Min	Max	Min	Max	
f_{SCL}	SCL Clock Frequency	—	100	—	400	—	1000	kHz
$t_{SCL(H)}$	SCL Clock High Time	4.5	—	1.125	—	0.45	—	μ s
$t_{SCL(L)}$	SCL Clock Low Time	4.5	—	1.125	—	0.45	—	μ s
t_{FALL}	SCL and SDA Fall Time	—	1.3	—	0.34	—	0.135	μ s
t_{RISE}	SCL and SDA Rise Time	—	1.3	—	0.34	—	0.135	μ s
$t_{SU(SDA)}$	SDA Data Setup Time	500	—	125	—	50	—	ns
$t_{H(SDA)}$	SDA data hold time (Note 5)	0	—	0	—	0	—	ns
	SDA data hold time (Note 6)	100	—	100	—	100	—	ns
$t_{VD(SDA)}$	SDA data valid time	—	1.6	—	0.475	—	0.25	μ s
$t_{SU(STA)}$	START Condition Setup Time	500	—	125	—	50	—	ns
$t_{H(STA)}$	START Condition Hold Time	0	—	0	—	0	—	ns
$t_{SU(STO)}$	STOP Condition Setup Time	500	—	125	—	50	—	ns

Note: 1. Data based on characterization results only, not tested in production.

2. To achieve 100 kHz standard mode, the peripheral clock frequency must be higher than 2MHz.

3. To achieve 400 kHz fast mode, the peripheral clock frequency must be higher than 8MHz.

4. To achieve 1MHz fast mode plus, the peripheral clock frequency must be higher than 20MHz.

5. The above characteristic parameters of the I²C bus timing are based on: COMB_FILTER_En = 0 and SEQ_FILTER = 00.

6. The above characteristic parameters of the I²C bus timing are based on: COMB_FILTER_En = 1 and SEQ_FILTER = 00.

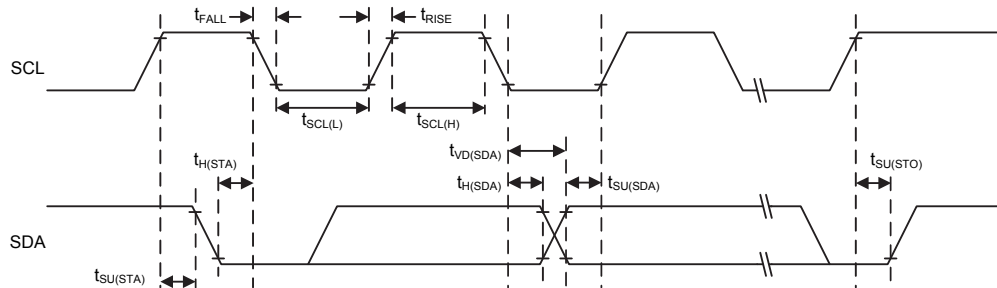

Figure 11. I²C Timing Diagrams

SPI Characteristics

Table 24. SPI Characteristics

Symbol	Parameter	Conditions	Min	Typ	Max	Unit
SPI Master Mode						
f_{SCK} ($1/t_{SCK}$)	SPI master output SCK clock frequency	Master mode, SPI peripheral clock frequency f_{PCLK}	—	—	$f_{PCLK}/2$	MHz
$t_{SCK(H)}$ $t_{SCK(L)}$	SCK clock high and low time		$t_{SCK}/2$ -2	—	$t_{SCK}/2$ +1	ns
$t_{V(MO)}$	Data output valid time	—	—	—	5	ns
$t_{H(MO)}$	Data output hold time	—	2	—	—	ns
$t_{SU(MI)}$	Data input setup time	—	5	—	—	ns
$t_{H(MI)}$	Data input hold time	—	5	—	—	ns
SPI Slave Mode						
f_{SCK} ($1/t_{SCK}$)	SPI master output SCK clock frequency	Slave mode, SPI peripheral clock frequency f_{PCLK}	—	—	$f_{PCLK}/3$	MHz
$Duty_{SCK}$	SPI slave input SCK clock duty cycle		30	—	70	%
$t_{SU(SEL)}$	SEL enable setup time	—	$3 t_{PCLK}$	—	—	ns
$t_{H(SEL)}$	SEL enable hold time	—	$2 t_{PCLK}$	—	—	ns
$t_{A(SO)}$	Data output access time	—	—	—	$3 t_{PCLK}$	ns
$t_{DIS(SO)}$	Data output disable time	—	—	—	10	ns
$t_{V(SO)}$	Data output valid time	—	—	—	25	ns
$t_{H(SO)}$	Data output hold time	—	15	—	—	ns
$t_{SU(SI)}$	Data input setup time	—	5	—	—	ns
$t_{H(SI)}$	Data input hold time	—	4	—	—	ns

Note: $t_{SCK} = 1/f_{SCK}$; $t_{PCLK} = 1/f_{PCLK}$. SPI output (input) clock frequency f_{SCK} ; SPI peripheral clock frequency f_{PCLK} .

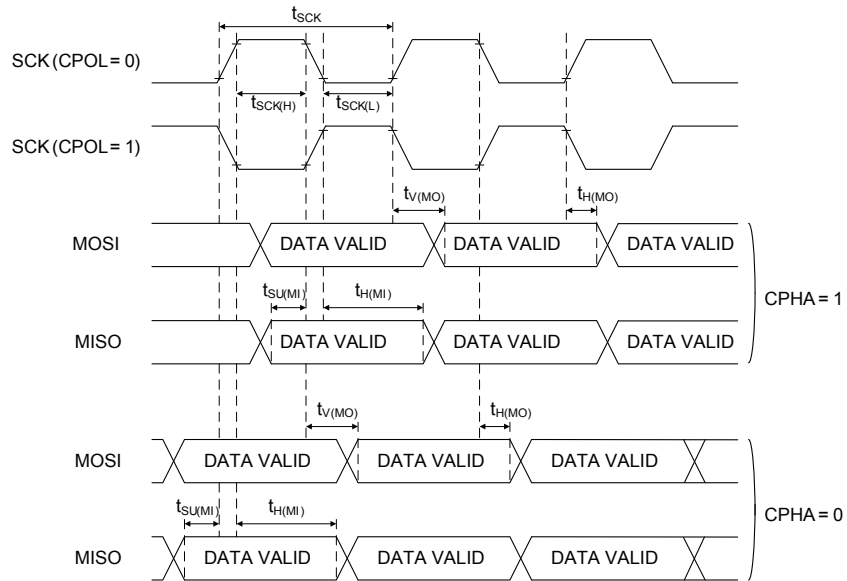

Figure 12. SPI Timing Diagrams – SPI Master Mode

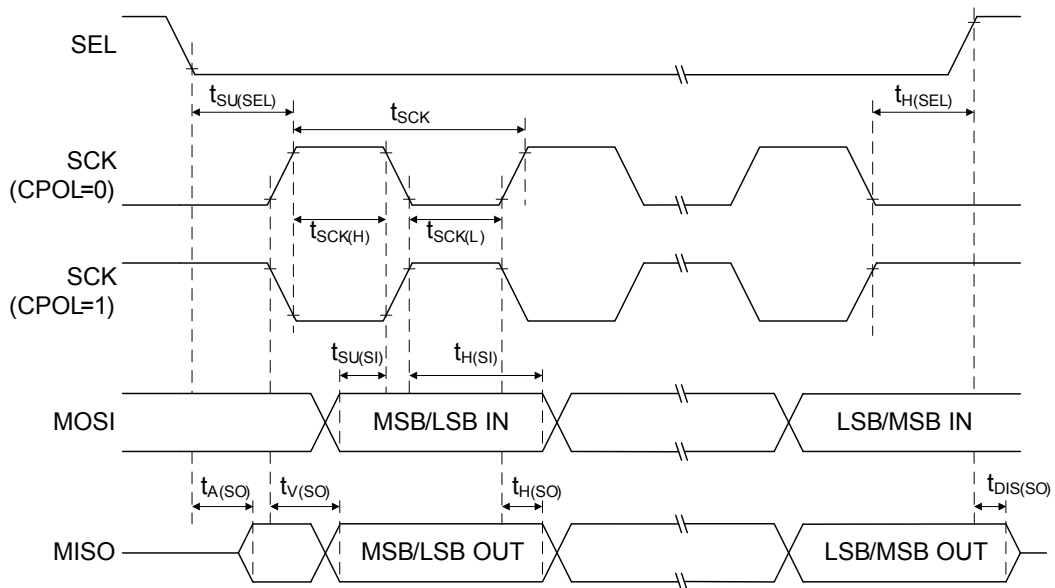

Figure 13. SPI Timing Diagrams – SPI Slave Mode with CPHA=1

USB Characteristics

The USB interface is USB-IF certified – Full Speed.

Table 25. USB DC Electrical Characteristics

Symbol	Parameter	Conditions	Min	Typ	Max	Unit
V_{DD}	USB Operating Voltage	—	3.0	—	3.6	V
V_{DI}	Differential Input Sensitivity	USBDP - USBDM	0.2	—	—	V
V_{CM}	Common Mode Voltage Range	—	0.8	—	2.5	V
V_{SE}	Single-ended Receiver Threshold	—	0.8	—	2.0	V
V_{OL}	Pad Output Low Voltage	RL of 1.5kΩ to V_{DD33}	0	—	0.3	V
V_{OH}	Pad Output High Voltage		2.8	—	3.6	V
V_{CRS}	Differential Output Signal Cross-point Voltage		1.3	—	2.0	V
Z_{DRV}	Driver Output Resistance	—	—	10	—	Ω
C_{IN}	Transceiver Pad Capacitance	—	—	—	20	pF

Note: 1. Data based on characterization results only, not tested in production.

2. The USB functionality is ensured down to 2.7V but for not the full USB electrical characteristics which will experience degradation in the 2.7V to 3.0V V_{DD} voltage range.

3. RL is the load connected to the USB driver USBDP.

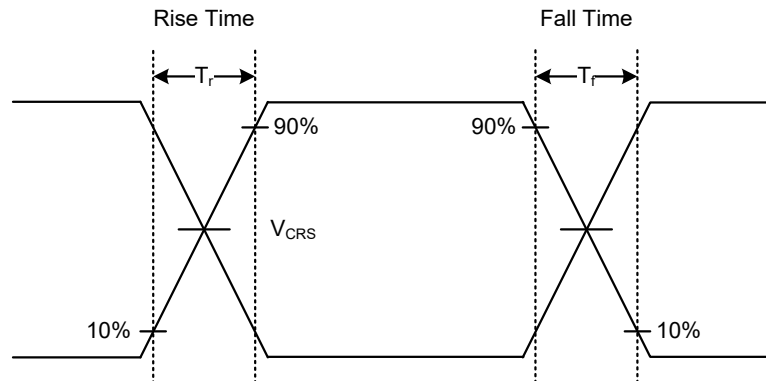

Figure 14. USB Signal Rise Time and Fall Time and Cross-point Voltage (VCRS) Definition

Table 26. USB AC Electrical Characteristics

Symbol	Parameter	Conditions	Min	Typ	Max	Unit
t_r	Rise time	$C_L = 50\text{pF}$	4	—	20	ns
t_f	Fall time	$C_L = 50\text{pF}$	4	—	20	ns
$t_{r/f}$	Rise time / fall time matching	$t_{r/f} = t_r / t_f$	90	—	110	%

6 Package Information

Note that the package information provided here is for consultation purposes only. As this information may be updated at regular intervals users are reminded to consult the [Holtek website](#) for the latest version of the [Package Information](#).

Additional supplementary information with regard to packaging is listed below. Click on the relevant section to be transferred to the relevant website page.

- Package Information (include Outline Dimensions, Product Tape and Reel Specifications)
- The Operation Instruction of Packing Materials
- Carton information

24-pin SSOP (150mil) Outline Dimensions

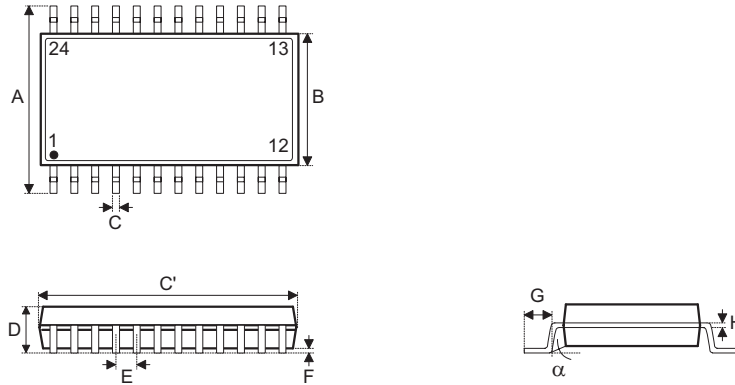

Symbol	Dimensions in inch		
	Min.	Nom.	Max.
A	—	0.236 BSC	—
B	—	0.154 BSC	—
C	0.008	—	0.012
C'	—	0.341 BSC	—
D	—	—	0.069
E	—	0.025 BSC	—
F	0.004	—	0.010
G	0.016	—	0.050
H	0.004	—	0.010
α	0°	—	8°

Symbol	Dimensions in mm		
	Min.	Nom.	Max.
A	—	6.0 BSC	—
B	—	3.9 BSC	—
C	0.20	—	0.30
C'	—	8.66 BSC	—
D	—	—	1.75
E	—	0.635 BSC	—
F	0.10	—	0.25
G	0.41	—	1.27
H	0.10	—	0.25
α	0°	—	8°

28-pin SSOP (150mil) Outline Dimensions

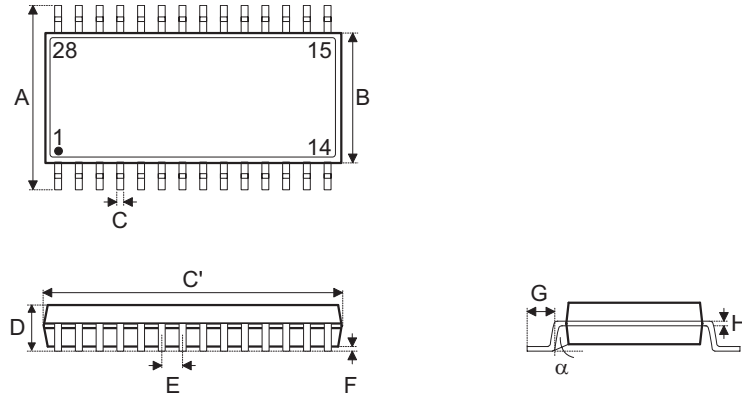

Symbol	Dimensions in inch		
	Min.	Nom.	Max.
A	—	0.236 BSC	—
B	—	0.154 BSC	—
C	0.008	—	0.012
C'	—	0.390 BSC	—
D	—	—	0.069
E	—	0.025 BSC	—
F	0.004	—	0.010
G	0.016	—	0.050
H	0.004	—	0.010
α	0°	—	8°

Symbol	Dimensions in mm		
	Min.	Nom.	Max.
A	—	6.0 BSC	—
B	—	3.9 BSC	—
C	0.20	—	0.30
C'	—	9.9 BSC	—
D	—	—	1.75
E	—	0.635 BSC	—
F	0.10	—	0.25
G	0.41	—	1.27
H	0.10	—	0.25
α	0°	—	8°

SAW Type 33-pin (4mm×4mm) QFN Outline Dimensions

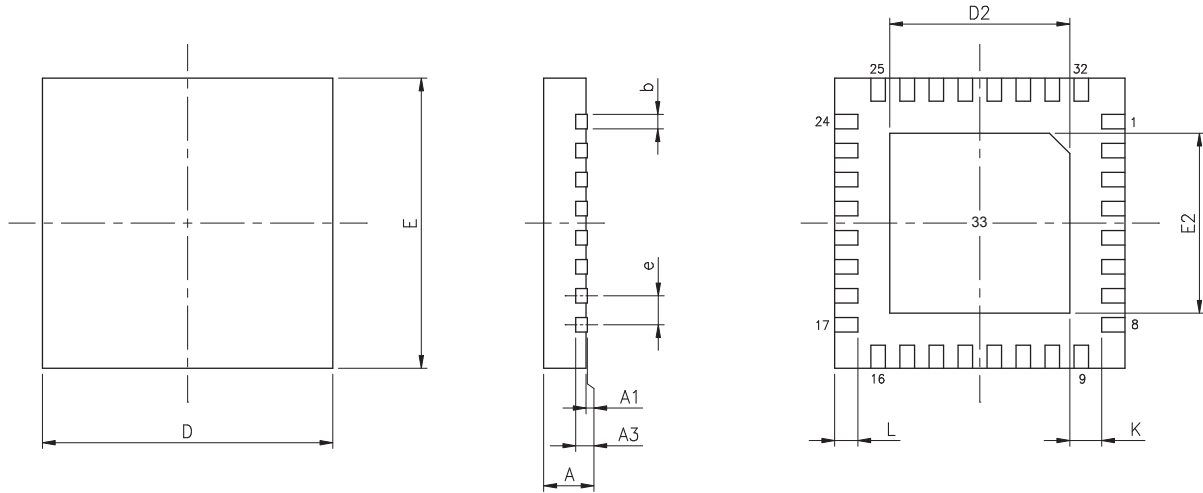

Symbol	Dimensions in inch		
	Min.	Nom.	Max.
A	0.028	0.030	0.031
A1	0.000	0.001	0.002
A3	—	0.008 REF	—
b	0.006	0.008	0.010
D	—	0.157 BSC	—
E	—	0.157 BSC	—
e	—	0.016 BSC	—
D2	0.100	—	0.108
E2	0.100	—	0.108
L	0.014	0.016	0.018
K	0.008	—	—

Symbol	Dimensions in mm		
	Min.	Nom.	Max.
A	0.70	0.75	0.80
A1	0.00	0.02	0.05
A3	—	0.203 REF	—
b	0.15	0.20	0.25
D	—	4.00 BSC	—
E	—	4.00 BSC	—
e	—	0.40 BSC	—
D2	2.55	—	2.75
E2	2.55	—	2.75
L	0.35	0.40	0.45
K	0.20	—	—

48-pin LQFP (7mm×7mm) Outline Dimensions

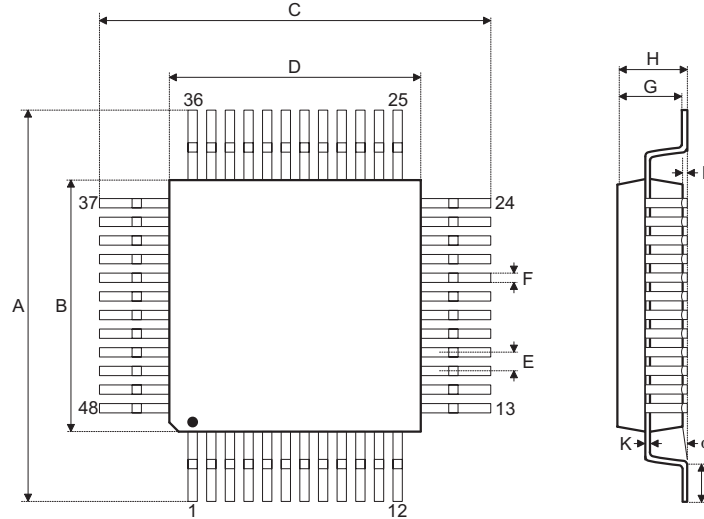

Symbol	Dimensions in inch		
	Min.	Nom.	Max.
A	—	0.354 BSC	—
B	—	0.276 BSC	—
C	—	0.354 BSC	—
D	—	0.276 BSC	—
E	—	0.020 BSC	—
F	0.007	0.009	0.011
G	0.053	0.055	0.057
H	—	—	0.063
I	0.002	—	0.006
J	0.018	0.024	0.030
K	0.004	—	0.008
α	0°	—	7°

Symbol	Dimensions in mm		
	Min.	Nom.	Max.
A	—	9.0 BSC	—
B	—	7.0 BSC	—
C	—	9.0 BSC	—
D	—	7.0 BSC	—
E	—	0.5 BSC	—
F	0.17	0.22	0.27
G	1.35	1.40	1.45
H	—	—	1.60
I	0.05	—	0.15
J	0.45	0.60	0.75
K	0.09	—	0.20
α	0°	—	7°

Copyright© 2023 by HOLTEK SEMICONDUCTOR INC. All Rights Reserved.

The information provided in this document has been produced with reasonable care and attention before publication, however, HOLTEK does not guarantee that the information is completely accurate. The information contained in this publication is provided for reference only and may be superseded by updates. HOLTEK disclaims any expressed, implied or statutory warranties, including but not limited to suitability for commercialization, satisfactory quality, specifications, characteristics, functions, fitness for a particular purpose, and non-infringement of any third-party's rights. HOLTEK disclaims all liability arising from the information and its application. In addition, HOLTEK does not recommend the use of HOLTEK's products where there is a risk of personal hazard due to malfunction or other reasons. HOLTEK hereby declares that it does not authorize the use of these products in life-saving, life-sustaining or safety critical components. Any use of HOLTEK's products in life-saving/sustaining or safety applications is entirely at the buyer's risk, and the buyer agrees to defend, indemnify and hold HOLTEK harmless from any damages, claims, suits, or expenses resulting from such use. The information provided in this document, including but not limited to the content, data, examples, materials, graphs, and trademarks, is the intellectual property of HOLTEK (and its licensors, where applicable) and is protected by copyright law and other intellectual property laws. No license, express or implied, to any intellectual property right, is granted by HOLTEK herein. HOLTEK reserves the right to revise the information described in the document at any time without prior notice. For the latest information, please contact us.