



ESK32-2x001 Expansion Board User Manual

Revision: V1.00 Date: November 18, 2016

www.holtek.com

Table of Contents

1 Introduction	5
Features.....	6
2 Hardware Layout	7
Audio Input Option	9
LCD Interface Option	9
Function Switch Description	10
SWD-20P Connector CN5	11
Extension Connector 1 – CN4.1	12
Extension Connector 2 – CN4.2	13
Multi-Interface CN1	14
RS232 Port Connector CN7	15
SD Card Connector CN8	16
LCD Connector CN2.....	17
CMOS Sensor Connector CN3.....	18
Smart Card Connector CN6.....	19
3 Schematics	20

List of Figures

Figure 1. ESK32-2x001 Expansion Board	5
Figure 2. ESK32-2x001 Expansion Board Block Diagram.....	7
Figure 3. ESK32-2x001 Expansion Board Layout	8
Figure 4. SWD-20P Connector CN5.....	11
Figure 5. Extension Connector 1	12
Figure 6. Extension Connector 2	13
Figure 7. Multi-Interface CN1.....	14
Figure 8. RS232 Port Connector CN7	15
Figure 9. SD Card Connector CN8	16
Figure 10. LCD Connector CN2.....	17
Figure 11. CMOS Sensor Connector CN3.....	18
Figure 12. Smart Card Connector CN6	19
Figure 13. LCD Connector, Multi-Interface and CMOS sensor.....	21
Figure 14. DVB to SK Connector, SWJ Connector and Fool Proofing	22
Figure 15. FLASH, EEPROM, TouchKey, Buttons, BUZZER, LED Display and Potentiometer	23
Figure 16. I ² S Audio Codec.....	24
Figure 17. Smart Card, SSI-SD Card and RS-232 Port0.....	25

List of Tables

Table 1. Audio Input DIP Switch.....	9
Table 2. EBI Interface Switch.....	9
Table 3. PC1 Switch Description.....	10
Table 4. Smart Card Switch Description	10
Table 5. SWD-10P Connector CN7.....	11
Table 6. Extension Connector 1	12
Table 7. Extension Connector 2.....	13
Table 8. Multi-Interface CN1	14
Table 9. RS232 Port 0 Connector CN7.....	15
Table 10. SD Card Connector CN10.....	16
Table 11. LCD Connector CN2.....	17
Table 12. CMOS Sensor Connector CN3	18
Table 13. Smart Card Connector CN6.....	19

1 Introduction

The ESK32-2x001 Expansion board is designed for use with the HT32F52xxx series of microcontrollers. The HT32F52xxx series of microcontrollers contain a variety of peripherals such as high speed SAR ADC, I²S, EBI, CRC, COMPARATOR, USB, I²C, USART, UART, SPI, GPTM, MCTM, WDT, RTC, SW-DP (Serial Wire) and etc.

There are some specific components to assist with device peripheral evaluation such as the RS232 transceiver, EEPROM, series NOR flash, Microphone, Stereo jack, potentiometer etc.

Note: There are only three components which are different between the ESK32-21001 and the ESK32-20001. These are the CMOS sensor connector, smart card connector and audio in/out which are only available in the ESK32-21001.

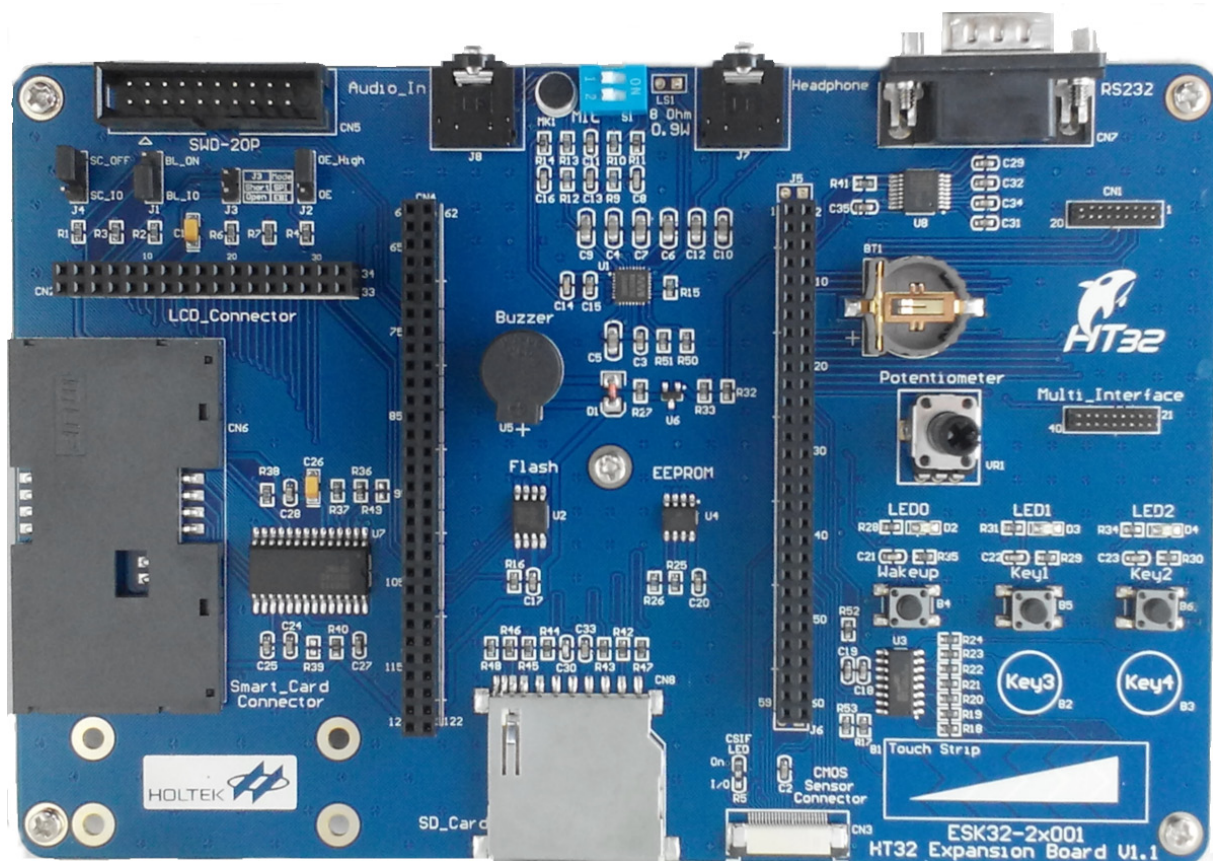
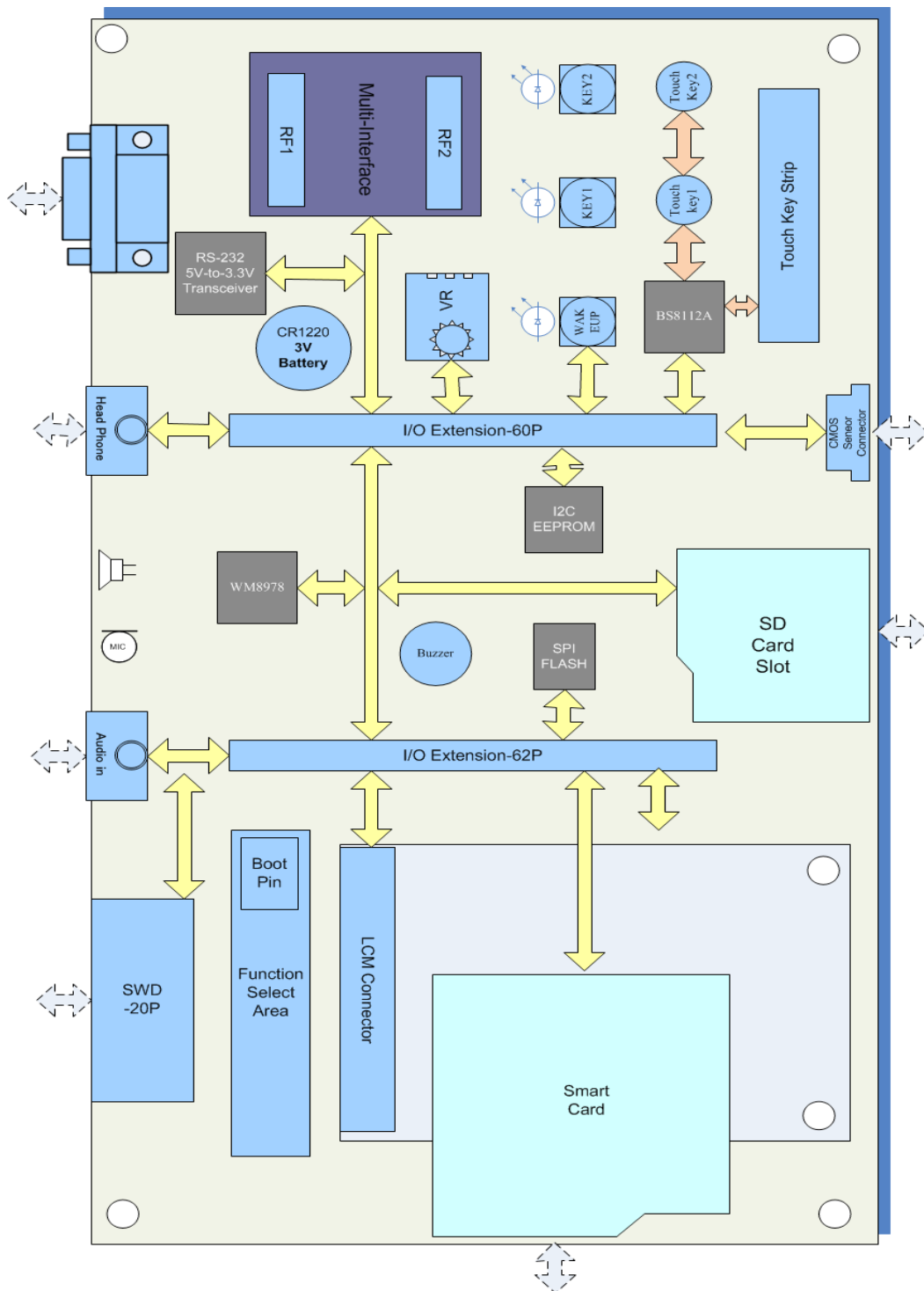


Figure 1. ESK32-2x001 Expansion Board

Features

- RS232 connector
- Wakeup and two key buttons
- Touch keys
- Three LEDs
- I²C – compatible serial interface EEPROM
- SPI – compatible serial interface Flash
- SPI and EBI extension interfaces for LCD display applications
- SD card slot – SPI mode
- PWM output for Buzzer driving
- Backup battery
- SWD-20P debug Port interface
- Smart card connector
- CMOS sensor connector
- Multi interface including UART, I²C, SPI and GPIO functions for connecting various modules
- Audio input contains microphone and stereo jack
- Audio output contains speaker connector and stereo jack

2 Hardware Layout



Hardware Layout

Figure 2. ESK32-2x001 Expansion Board Block Diagram

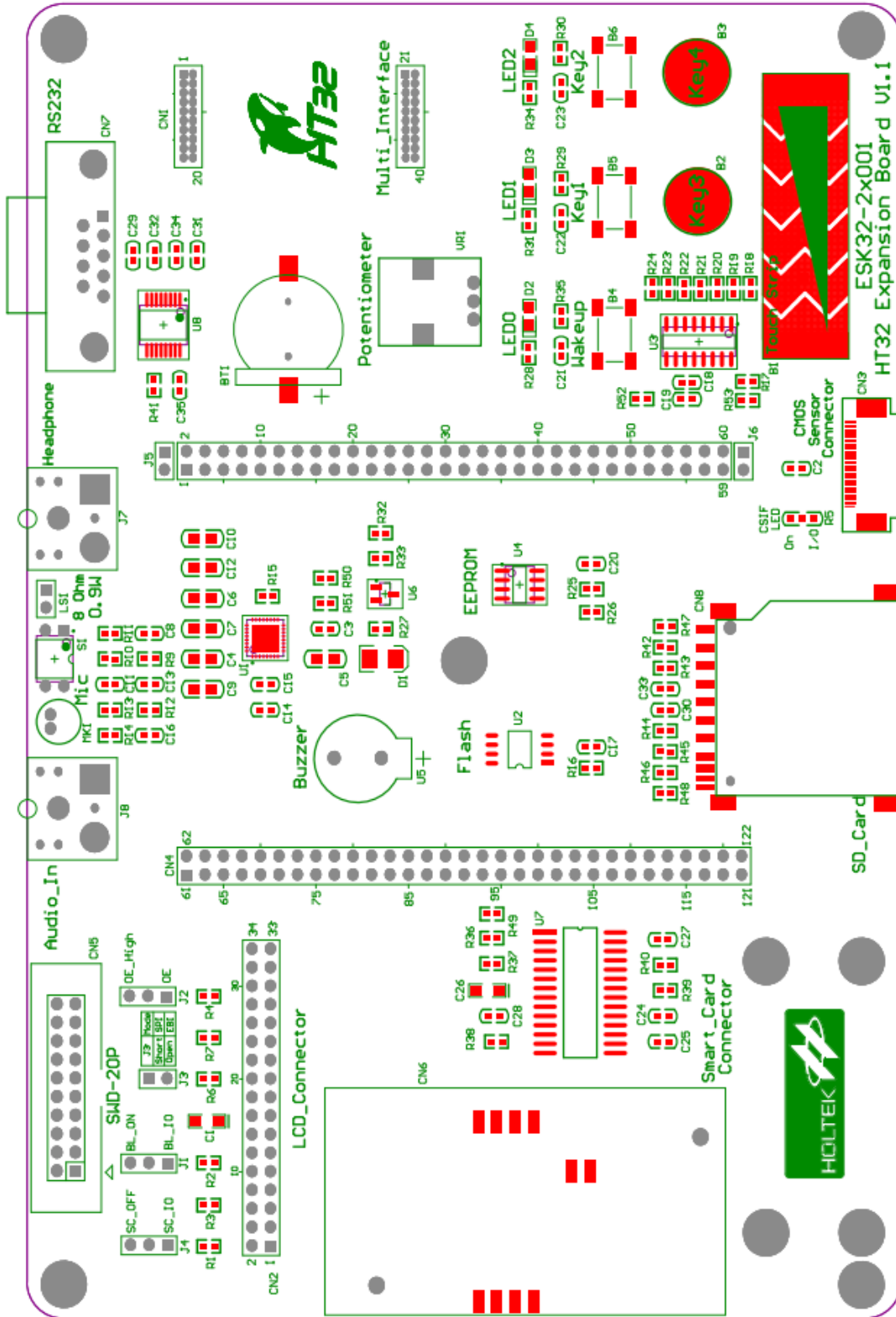
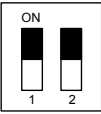
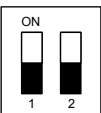


Figure 3. ESK32-2x001 Expansion Board Layout

Hardware Layout


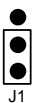


Audio Input Option

Table 1. Audio Input DIP Switch

Jumper	Description
S1	For audio inputs sourced from the Microphone (MK1) – default setting 
	For audio inputs sourced from the stereo jack (J2) 

LCD Interface Option

Table 2. EBI Interface Switch

Jumper	Description
J1	LCD Backlight will always be on 
	LCD Backlight controlled by IO pin 
J3	Short: LCD SPI mode 
	Open: LCD EBI mode – note that only the HT32F52342/52 can work in this mode 

Function Switch Description

Table 3. PC1 Switch Description

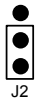


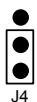
Jumper	Description
J2	The GPIO pin PC1 is switched to the EBI_OE pin  ● OE_High ○ OE J2
	The GPIO pin PC1 is switched to a pull high  ○ OE_High ● OE J2

Table 4. Smart Card Switch Description

Jumper	Description
J4	Smart Card function is off  ● SC_OFF ○ SC_IO J4
	Smart Card function is on – note that the Smart Card function and EBI function are unable to operate at the same time as they share a common pin  ○ SC_OFF ● SC_IO J4

SWD-20P Connector CN5

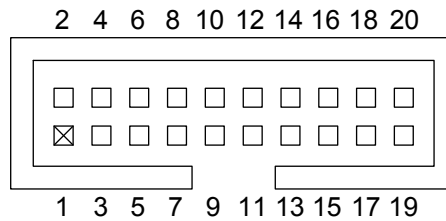


Figure 4. SWD-20P Connector CN5

Table 5. SWD-10P Connector CN7

Pin#	Description	Pin#	Description
1	3.3V	2	3.3
3	NC	4	GND
5	NC	6	GND
7	SWDIO(PA13)	8	GND
9	SWCLK(PA12)	10	GND
11	NC	12	GND
13	SWO	14	GND
15	nRST	16	GND
17	NC	18	GND
19	NC	20	GND

Extension Connector 1 – CN4.1

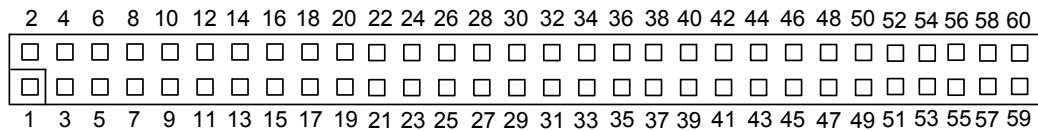


Figure 5. Extension Connector 1

Table 6. Extension Connector 1

Pin#	Description	Pin#	Description
1	GND	2	GND
3	I2S_BCLK(PC11)	4	I2S_WS(PC10)
5	RS232_RX(PA4)	6	RS232_TX(PA5)
7	PA9_BOOT1/M_IO4	8	BUZZER(PA10)
9	M_IO2(PB13)	10	M_IO3(PB14)
11	M_IO0(PB15)	12	M_IO1(PC0)
13	M_TX(PA2)	14	M_RX(PA3)
15	M_RTS(PA0)	16	M_CTS(PA1)
17	M_MISO(PC9)	18	M_CS(PA7)
19	M_SCK(PC5)	20	M_MOSI(PC8)
21	M_SDA(PA1)	22	M_SCL(PA0)
23	Touch_SDA(PA1)	24	Touch_SCL(PA0)
25	EE_SDA(PA1)	26	EE_SCL(PA0)
27	B0_WAKEUP(PB12)	28	V_BAT
29	Potentiometer(PA6)	30	GND
31	NC	32	Touch_IRQ(PB11)
33	SD_DP/MISO(PC9)	34	SD_D1
35	SD_D2	36	SD_D3/CS
37	SD_CLK(PC5)	38	SD_CMD/MOSI(PC8)
39	CSIF_LED	40	SD_CD
41	CSIF_SDA	42	CSIF_SCL
43	CSIF_RESB	44	CSIF_PWDN
45	CSIF_PCLK	46	CSIF_MCLK
47	CSIF_HSYNC	48	CSIF_VSYNC
49	CSIF_D6	50	CSIF_D7
51	CSIF_D4	52	CSIF_D5
53	CSIF_D2	54	CSIF_D3
55	CSIF_D0	56	CSIF_D1
57	GND	58	GND
59	VDD33	60	VDD33

Extension Connector 2 – CN4.2

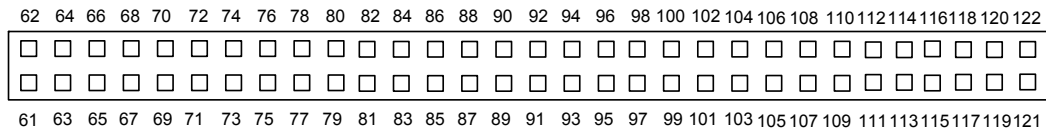


Figure 6. Extension Connector 2

Table 7. Extension Connector 2

Pin#	Description	Pin#	Description
61	VDD33	62	VDD33
63	GND	64	GND
65	I2S_SDA(PA1)	66	I2S_SCL(PA0)
67	I2S_SDO(PC12)	68	I2S_SDI(PC13)
69	PA9_BOOT1	70	I2S_MCLK(PA8)
71	SWO	72	Nrst
73	SWCLK(PA12)	74	SWDIO(PA13)
75	LCD_BL(PB6)	76	LCD_WE(PC3)
77	LCD_SDA(PA1)	78	LCD_SCL(PA0)
79	LCD_CS(PC2)	80	LCD_MISO(PC9)
81	LCD_SCK(PC5)	82	LCD_MOSI(PC8)
83	LCD_INT(PC0)	84	LCD_RST(PB7)
85	LCD_AD0(PA14)	86	LCD_AD1(PA15)
87	LCD_AD2(PB0)	88	LCD_AD3(PB1)
89	LCD_AD4(PB2)	90	LCD_AD5(PB3)
91	LCD_AD6(PB4)	92	LCD_AD7(PB5)
93	LCD_AD8(PC14)	94	LCD_AD9(PC15)
95	LCD_AD10(PD1)	96	LCD_AC11(PD2)
97	LCD_AD12(PD3)	98	LCD_AD13(PC10)
99	LCD_AD14(PC11)	100	LCD_AD15(PC12)
101	LCD_OE(PC1)	102	LCD_A0(PA11)
103	LCD_TS	104	GND
105	Flash_SCK(PC5)	106	Flash_MOSI(PC8)
107	Flash_MISO(PC9)	108	Flash_CS(PD0)
109	Button1(PD1)	110	Button2(PD2)
111	LED0(PC14)	112	LED1(PC15)
113	LED2(PC1)	114	SCI_CMD(PD3)
115	SCI_RST(PC15)	116	SCI_CLK(PB6)
117	SCI_DET(PB7)	118	SCI_DIO(PB8)
119	GND	120	GND
121	DC5V	122	DC5V

Multi-Interface CN1

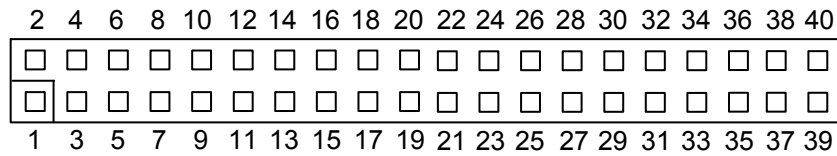


Figure 7. Multi-Interface CN1

Table 8. Multi-Interface CN1

Pin#	Description	Pin#	Description
1	VSS	2	NC
3	M_RTS(PA0)	4	NC
5	NC	6	M_TX(PA2)
7	M_TX(PA2)	8	M_RX(PA3)
9	M_RX(PA3)	10	M_IO0(PB15)
11	NC	12	M_IO1(PC0)
13	NC	14	M_CS(PA7)
15	NC	16	M_SCK(PC5)
17	NC	18	M_MOSI(PC8)
19	GND	20	M_MISO(PC9)
21	NC	22	VSS
23	NC	24	NC
25	NC	26	NC
27	3.3V	28	NC
29	3.3V	30	NC
31	NC	32	M_SCL(PA0)
33	M_IO2(PB13)	34	M_SDA(PA1)
35	NC	36	NC
37	NC	38	M_CTS(PA1)
39	M_IO3(PB14)	40	M_IO4(PA9)

RS232 Port Connector CN7

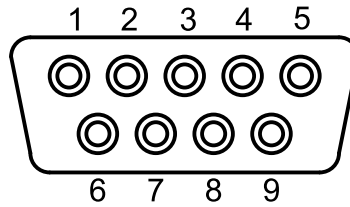


Figure 8. RS232 Port Connector CN7

Table 9. RS232 Port 0 Connector CN7

Pin#	Description	Pin#	Description
1	Connect to PIN4	2	UART0_Rx (PA4)
3	UART0_Tx (PA5)	4	Connect to PIN6
5	GND	6	Connect to PIN1
7	Connect to PIN8	8	Connect to PIN7
9	NC		

SD Card Connector CN8

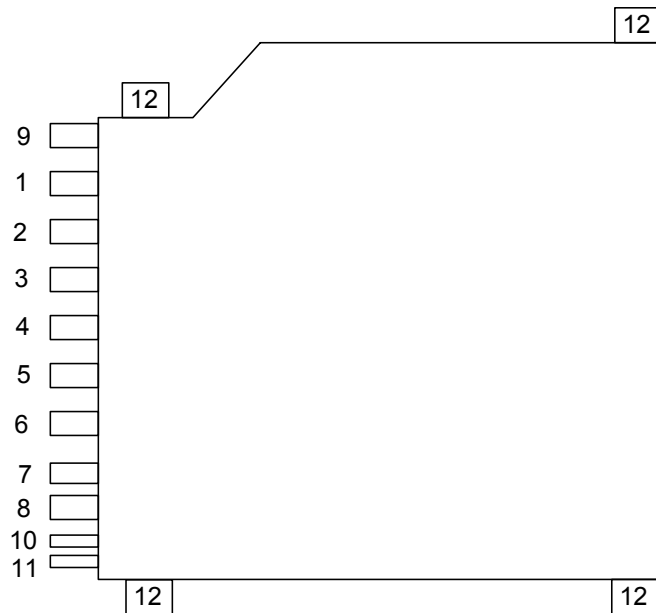


Figure 9. SD Card Connector CN8

Table 10. SD Card Connector CN10

Pin#	Description	Pin#	Description
1	SD_D3/CS(PC4)	2	SD_CMD/MOSI(PC8)
3	GND	4	3.3V
5	SD_SCK(PC5)	6	GND
7	SD_D0/MISO(PC9)	8	NC
9	NC	10	Pull high
11	NC	12	GND

LCD Connector CN2

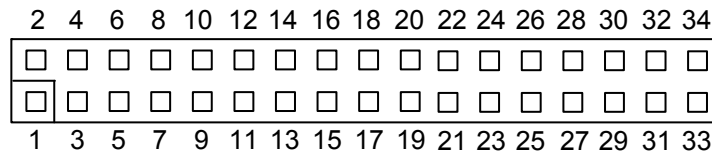


Figure 10. LCD Connector CN2

Table 11. LCD Connector CN2

Pin#	Description	Pin#	Description
1	5V	2	GND
3	LCD_BL(J1)	4	LCD_SDA(PA1)
5	LCD_SCL(PA0)	6	WE_WE(PC3)
7	LCD_MISO(PC9)	8	LCD_MOSI(PC8)
9	LCD_CS(PC2)	10	LCD_INT(PC0)
11	NC	12	LCD_RST(PB7)
13	GND	14	3.3V
15	LCD_AD0(PA14)	16	LCD_AD1(PA15)
17	LCD_AD2(PB0)	18	LCD_AD3(PB1)
19	LCD_AD4(PB2)	20	LCD_AD5(PB3)
21	LCD_AD6(PB4)	22	LCD_AD7(PB5)
23	LCD_AD8(PC14)	24	LCD_AD9(PC15)
25	LCD_AD10(PD1)	26	LCD_AD11(PD2)
27	LCD_AD12(PD3)	28	LCD_AD13(PC10)
29	LCD_AD14(PC11)	30	LCD_AD15(PC12)
31	NC	32	NC
33	LCD_OE(PC1)	34	LCD_A0(PA11)

CMOS Sensor Connector CN3

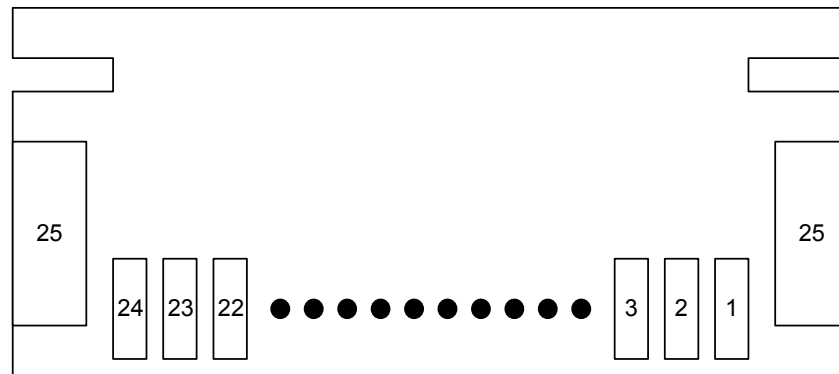


Figure 11. CMOS Sensor Connector CN3

Table 12. CMOS Sensor Connector CN3

Pin#	Description	Pin#	Description
1	NC	2	CSIF_LED
3	CSIF_RESB	4	CSIF_D0
5	CSIF_D1	6	CSIF_D2
7	CSIF_D3	8	CSIF_D4
9	CSIF_D5	10	CSIF_D6
11	CSIF_D7	12	3.3V
13	3.3V	14	CSIF_SCL
15	CSIF_SDA	16	GND
17	GND	18	CSIF_VSYNC
19	CSIF_HSYNC	20	GND
21	CSIF_MCLK	22	GND
23	CSIF_PCLK	24	CSIF_PWDN
25	GND		

Smart Card Connector CN6

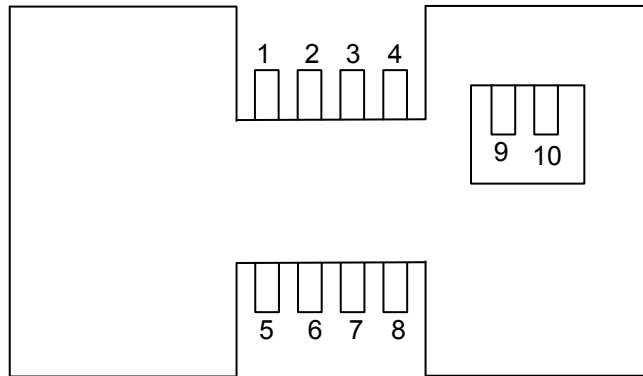


Figure 12. Smart Card Connector CN6

Table 13. Smart Card Connector CN6

Pin#	Description	Pin#	Description
1	VCC	2	RST
3	CLK	4	NC
5	GND	6	NC
7	I/O	8	NC
9	PRES	10	VDD

3 Schematics

This section shows the complete circuit for the ESK32-2x001 Expansion Board:

- Figure 13. includes the LCD Connector, Multi-Interface and CMOS sensor.
- Figure 14. includes the DVB to SK Connector, SWJ Connector and Fool Proofing.
- Figure 15. includes the FLASH, EEPROM, TouchKey, Buttons, BUZZER, LED Display and Potentiometer.
- Figure 16. includes the I²S Audio Codec.
- Figure 17. includes the Smart Card, SSI-SD Card and RS-232 Port0.

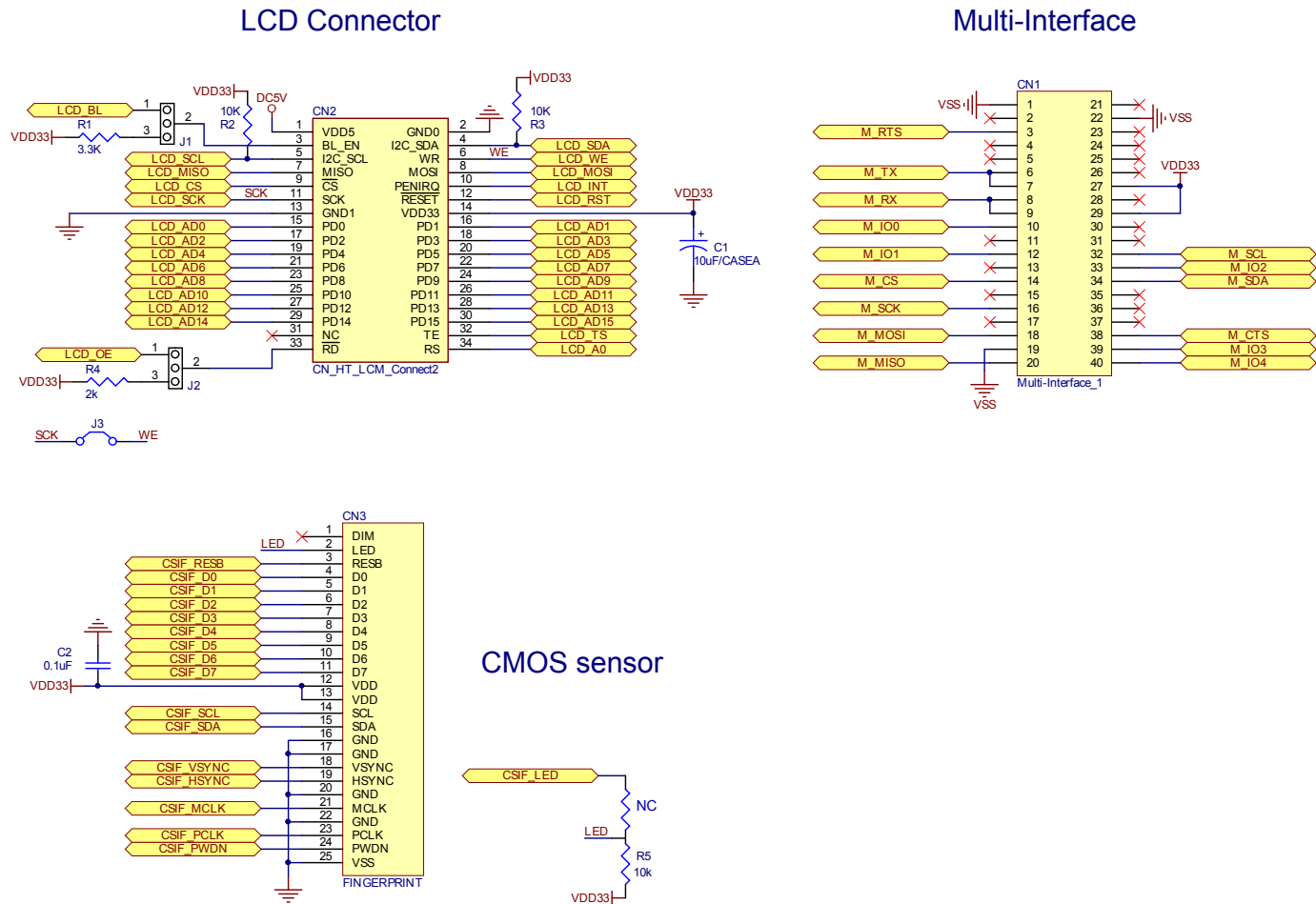
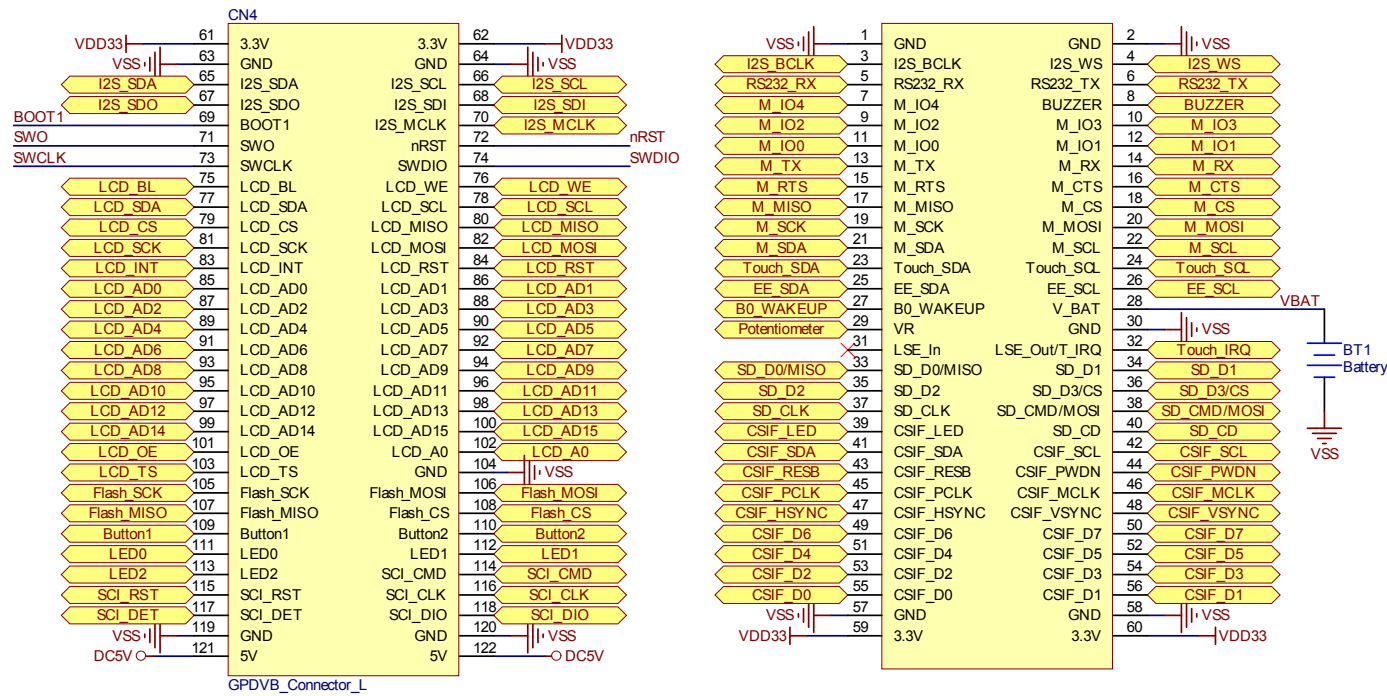
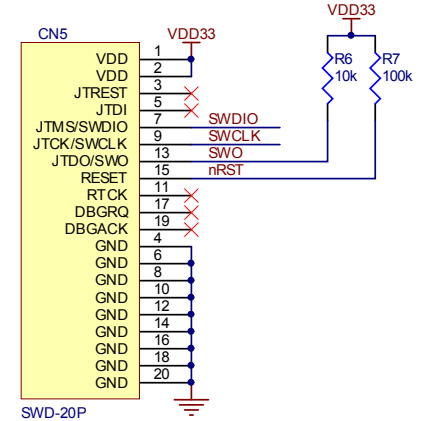


Figure 13. LCD Connector, Multi-Interface and CMOS sensor

DVB to SK Connector



SWJ Connector



Fool proofing

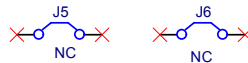


Figure 14. DVB to SK Connector, SWJ Connector and Fool Proofing

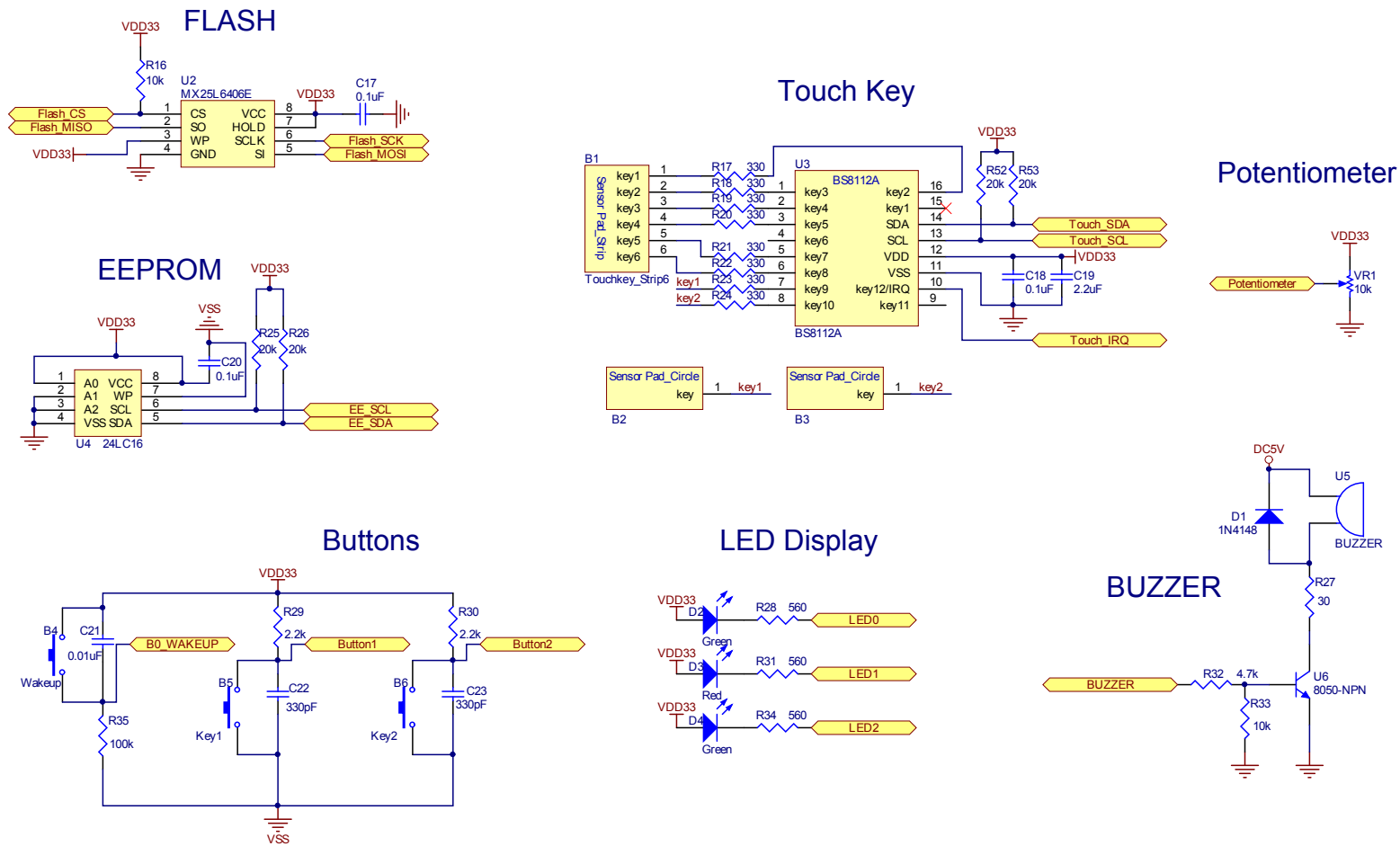


Figure 15. FLASH, EEPROM, TouchKey, Buttons, BUZZER, LED Display and Potentiometer

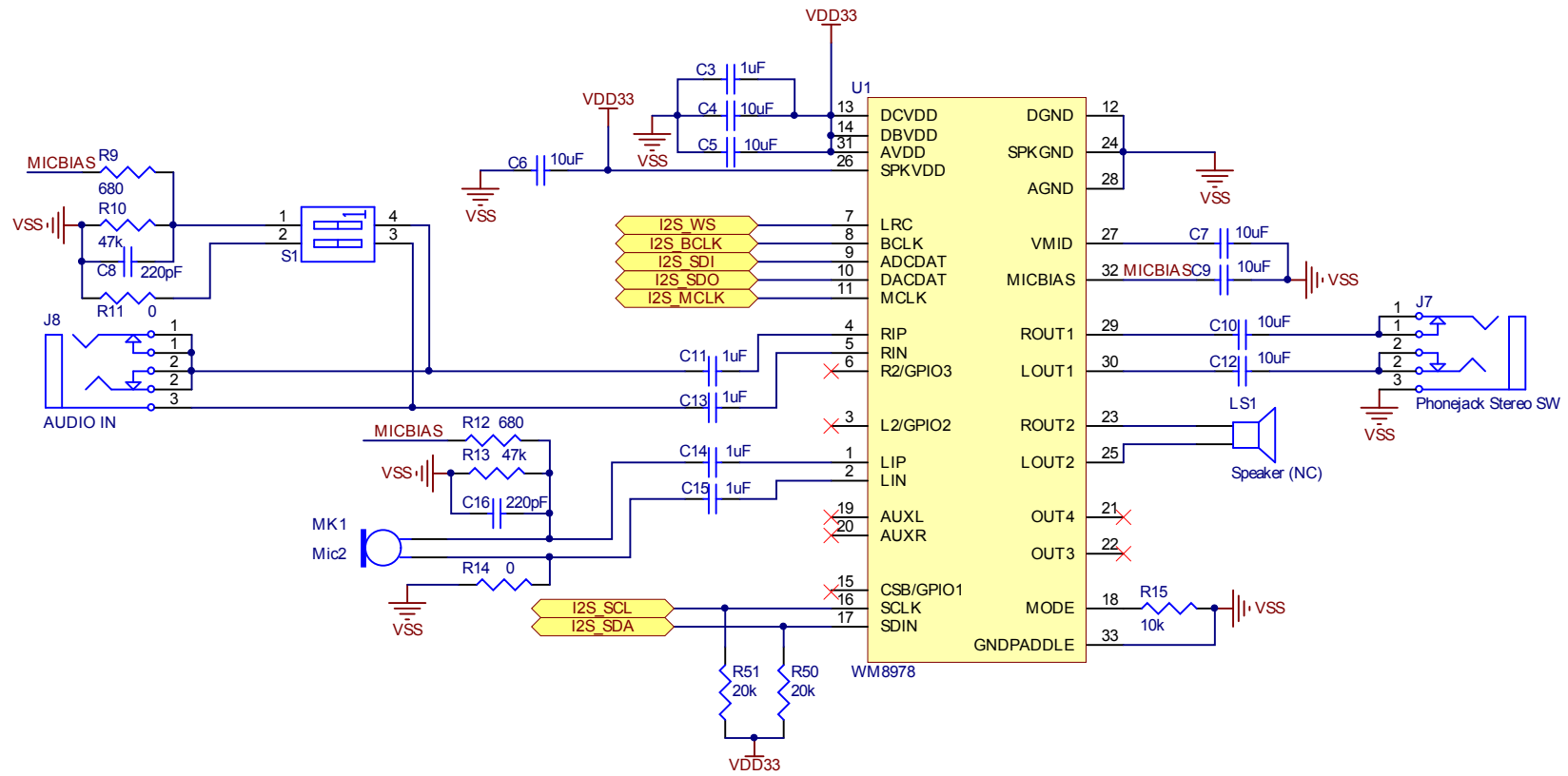


Figure 16. I²S Audio Codec

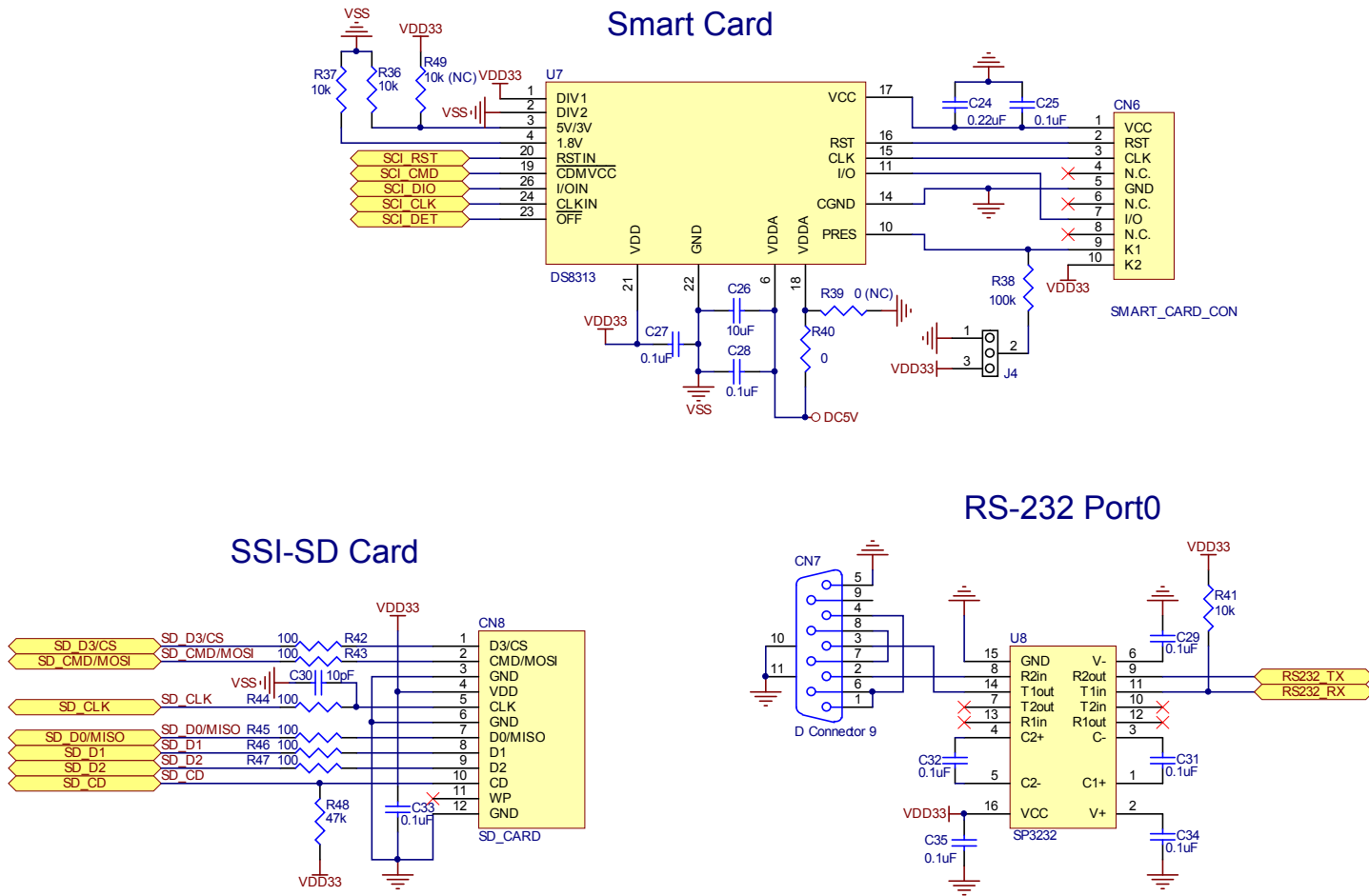


Figure 17. Smart Card, SSI-SD Card and RS-232 Port0

Copyright© 2016 by HOLTEK SEMICONDUCTOR INC.

The information appearing in this Data Sheet is believed to be accurate at the time of publication. However, Holtek assumes no responsibility arising from the use of the specifications described. The applications mentioned herein are used solely for the purpose of illustration and Holtek makes no warranty or representation that such applications will be suitable without further modification, nor recommends the use of its products for application that may present a risk to human life due to malfunction or otherwise. Holtek's products are not authorized for use as critical components in life support devices or systems. Holtek reserves the right to alter its products without prior notification. For the most up-to-date information, please visit our web site at <http://www.holtek.com.tw/en/home>.