



DALI DT6/DT8(Tc) Control Module

BM82D8021-1

Revision: V1.10 Date: June 24, 2024

www.bestmodulescorp.com

Table of Contents

Features	3
General Description	3
Applications	3
Block Diagram	4
Pin Assignment	4
Pin Description	4
Technical Specifications	5
Absolute Maximum Ratings	5
Recommended Operating Conditions	5
D.C. Electrical Characteristics.....	5
A.C. Electrical Characteristics.....	6
Functional Description	6
System Description	6
Instructions for Use	6
Supported Commands	7
Application Circuits	10
Layout Description	10
PCB Footprint.....	10
Layout Guidelines	11
Dimensions	11
Reference Information	11
Modification History.....	11
Buy Online.....	11

Features

- DALI interface features
 - ♦ Bus operating voltage: 9.5V~22.5V
 - ♦ Bus current consumption: <2mA
 - ♦ High withstand voltage, preventing misconnection to mains power
 - ♦ Isolation voltage between MCU circuit: 5kV
- PWM output
 - ♦ Resolution: 0.1%
 - ♦ Range: 0%~100%
 - ♦ Default minimum brightness: 1%
 - ♦ Voltage amplitude: 0V~5V
 - ♦ Frequency: 1kHz
- LED fault detection
 - ♦ Open circuit detection: <0.6V
 - ♦ Short circuit detection: >4.5V
- Default colour temperature range: 2700K~6500K
- Operating voltage: 7V~30V
- Operating current: <10mA
- Operating temperature: -25°C~85°C
- Conform to IEC62386-102 ed2.0 / 207 ed2.0 / 209(Tc) ed1.0
- Power-off data retention time: ≤50ms
- Module size: 40mm×17mm×6.5mm

General Description

The BM82D8021-1 is a DALI-2 compliant DALI DT6/DT8(Tc) control module, which communicates with the host device via the DALI bus and converts DALI commands into PWM output signals for the DALI LED driver. The small package size of the module makes it easier to connect to the PCBA of the LED driver. By using Iset pin external resistors, the module can be well adapted to constant current drivers that require different output currents.

Applications

- DALI LED constant voltage drivers
- DALI LED constant current drivers

Block Diagram

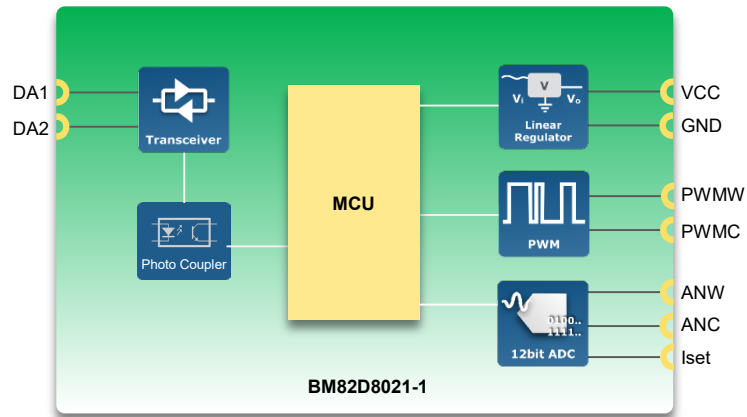

Pin Assignment

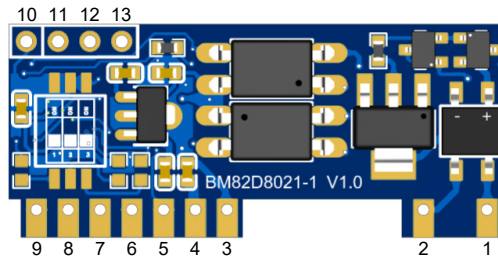

Pin Description

Pin	Function	Type	Description
1	DA1	I/O	DALI signal interface
2	DA2	I/O	DALI signal interface
3	VCC	PWR	Positive power supply
4	GND	PWR	Negative power supply, ground
5	PWMW	PWM	PWM output pin (warm colour), push-pull output, high active
6	PWMC	PWM	PWM output pin (cool colour), push-pull output, high active
7	ANW	ADC	Fault detection pin (warm colour), with an internal 10kΩ pull-down resistor
8	ANC	ADC	Fault detection pin (cool colour), with an internal 10kΩ pull-down resistor
9	Iset	ADC	Current limit level detection pin
10	GND	PWR	Programming interface negative power supply, ground
11	ICPCK/RX	UART	Programming interface clock pin / module UART RX pin
12	ICPDA/TX	UART	Programming interface data pin / module UART TX pin
13	VDD	PWR	Programming interface positive power supply

Legend: PWR: Power; I/O: Digital input/output; ADC: ADC input; PWM: PWM output

The PWMW/PWMC pins of the module have no internal pull-up/down resistors and are in a floating state during the power-on reset. Pay attention to whether this state will have an effect on the LED driver, such as the LED may flash slightly when the module is powered on.

Refer to the Holtek DALI Workshop User Guide for details on updating parameters through the module UART interface.

Technical Specifications

Absolute Maximum Ratings

Operating Voltage.....	5.2V~40V
DALI Interface Withstand Voltage.....	260V AC
Storage Temperature.....	-40°C~125°C
Operating (Ambient) Temperature.....	-25°C~85°C

Note: Stresses exceeding the range specified under “Absolute Maximum Ratings” may cause substantial damage to the module. Functional operation of the module at other conditions beyond those listed in the specification is not implied and prolonged exposure to extreme conditions may affect module reliability.

Recommended Operating Conditions

When adapting the module to a driver, pay attention to the following conditions:

1. The time interval from driver power on to providing stable voltage to module should be as short as possible, which is recommended to be less than 150ms.
2. After the driver is powered off, the time period for module power supply decreasing from 4.2V to 3.8V should be greater than 50ms, which is used for module power-off data retention.
3. The driver needs to ensure the normal operation of the module within 200ms of power input (regardless of AC or DC power supply) temporary disconnection. This can be achieved by placing a larger electrolytic capacitor in the front stage of the module’s power supply end.
4. The fault detection feedback voltage provided by the driver should not exceed 5V.
5. The wiring length of the DALI bus can be up to 300 meters. It is recommended to place protective components such as varistors and safety capacitors between the driver and the module DALI interface so as to improve resistance to surge impacts.

D.C. Electrical Characteristics

Ta=25°C

Parameter	Test Conditions	Min.	Typ.	Max.	Unit
Operating Voltage (V _{CC})	—	7	—	30	V
Operating Current (I _{CC})	—	—	6.5	10	mA
DALI Communication Voltage	—	9.5	16	22.5	V
DALI Input Current	—	—	1.4	2	mA
PWM Output Voltage (V _{OH})	I/O -8mA drive, I _{OH} =-8mA	4.5	—	5	V
PWM Output Voltage (V _{OL})	I/O 32mA drive, I _{OL} =32mA	0	—	0.5	V
PWM Output Current (I _{OL})	V _{OL} =0.5V	32	65	—	mA
PWM Output Current (I _{OH})	V _{OH} =4.5V	-8	-16	—	mA
ANC Input Range	—	0	—	5	V
ANW Input Range	—	0	—	5	V
Iset Input Range	—	0	—	5	V

A.C. Electrical Characteristics

Ta=25°C

Parameter	Test Conditions	Min.	Typ.	Max.	Unit
Power-on Time	From $V_{CC} \geq 4.2V$ to communication ready	—	50	—	ms
Power-off Data Retention Time	$4.2V \geq V_{CC} \geq 3.8V$	—	38	50	ms
PWM Frequency	—	—	1	—	kHz
PWM Resolution	—	—	0.1	—	%
PWM Range	—	0	—	100	%

Functional Description

System Description

The module has two PWM output pins, two fault detection pins and one current limit level detection pin. A DALI development platform named DALI Workshop is also provided by Holtek, with which the module can flexibly adjust the PWM output ratio and the minimum brightness of each current level, start-up time, fault detection thresholds, GTIN product code, etc., according to the characteristics of the driver.

Operating Principle

The module communicates with the DALI host through the DALI signal interface. The front end of the module is a DALI signal transceiver circuit, the bus signals are processed through the transceiver circuit, optocoupled by the photo coupler and then transmitted to the rear-end MCU. The rear-end MCU transmits the signals to the transceiver circuit through the photo coupler to control the bus for communication.

After receiving the complete commands, the module processes the commands and then controls the driver by adjusting the PWM output signals, so as to adjust the brightness and colour temperature of the lamps.

Instructions for Use

The following aspects should be noted when adapting the module to a driver.

1. The module provides two fault status detection pins, through which the voltage are input to the ADC for measurement so as to determine the lamp fault status. The default open circuit detection threshold is 0.6V, a feedback voltage less than 0.6V indicates an open circuit status. The default short circuit detection threshold is 4.5V, a feedback voltage greater than 4.5V indicates a short circuit status. Note that the feedback voltage must not be greater than 5V.
2. The module's PWMW pin corresponds to the fault detection pin ANW and PWMC corresponds to ANC. The module is powered on to cool colour by default. PWMC is the cool colour control signals and PWMW is the warm colour control signal.
3. The module's Iset pin is used to control the PWM output ratio and the default PWM minimum brightness is 1%.

When using the Iset pin for control, it is recommended to add one 3-bit DIP switch and three resistors on the driver for Iset level selection. The DIP resistance values are SW1=56kΩ, SW2=30kΩ and SW3=16kΩ.

The relationship between the Iset external resistor DIP status, Iset level, default PWM output control ratio and PHM level is as follows:

DIP Switch Status (321)	Corresponding Iset Level	Default PWM Ratio	Default PHM Level
000	1	100%	86
001	2	90%	89
010	3	80%	94
011	4	70%	98
100	5	60%	106
101	6	50%	111
110	7	40%	119
111	8	30%	130

To modify the minimum brightness, PHM level and PWM control ratio of the module, users can customize the parameters through the Holtek's DALI Workshop.

- After modifying the PWM ratio of the current level, the minimum physical brightness level (PHM level) of the corresponding current level also needs to be modified. Refer to the variable setting FAQ file of the Holtek's DALI Workshop.
- The default colour temperature range of the module is 2700K~6500K, and it can be changed using the Holtek's DALI WorkShop according to the driver parameter requirements. It should be noted that the difference between the coolest value and the warmest value of the physical colour temperature shall not exceed 700.
- The module supports product identification number setting, refer to the "Module Parameter Setting" section of the Holtek's DALI Workshop User Guide for more details.

Supported Commands

IEC62386-102 ed2.0 Protocol Commands

Command No.	Command Format	Command Name
—	YAAA AAA0 XXXX XXXX	DAPC (Direct Arc Power Control)
0	YAAA AAA1 0000 0000	OFF
1	YAAA AAA1 0000 0001	UP
2	YAAA AAA1 0000 0010	DOWN
3	YAAA AAA1 0000 0011	STEP UP
4	YAAA AAA1 0000 0100	STEP DOWN
5	YAAA AAA1 0000 0101	RECALL MAX LEVEL
6	YAAA AAA1 0000 0110	RECALL MIN LEVEL
7	YAAA AAA1 0000 0111	STEP DOWN AND OFF
8	YAAA AAA1 0000 1000	ON AND SETP UP
9	YAAA AAA1 0000 1001	ENABLE DAPC SEQUENCE
10	YAAA AAA1 0000 1010	GO TO LAST ACTIVE LEVEL
11~15	—	Reserved
16~31	YAAA AAA1 0001 XXXX	GO TO SCENE
32	YAAA AAA1 0010 0000	RESET
33	YAAA AAA1 0010 0001	STORE ACTUAL LEVEL IN DTR0
34	—	Reserved
35	YAAA AAA1 0010 0011	SET OPERATING MODE
36	YAAA AAA1 0010 0100	RESET MEMORY BANK
37	YAAA AAA1 0010 0101	IDENTIFY DEVICE
38~41	—	Reserved
42	YAAA AAA1 0010 1010	SET MAX LEVEL
43	YAAA AAA1 0010 1011	SET MIN LEVEL
44	YAAA AAA1 0010 1100	SET SYSTEM FAILURE LEVEL

Command No.	Command Format	Command Name
45	YAAA AAA1 0010 1101	SET POWER ON LEVEL
46	YAAA AAA1 0010 1110	SET FADE TIME
47	YAAA AAA1 0010 1111	SET FADE RATE
48	YAAA AAA1 0011 0000	SET EXTENDED FADE TIME
49~63	—	Reserved
64~79	YAAA AAA1 0100 XXXX	SET SCENE
80~95	YAAA AAA1 0101 XXXX	REMOVE FROM SCENE
96~111	YAAA AAA1 0110 XXXX	ADD TO GROUP
112~127	YAAA AAA1 0111 XXXX	REMOVE FROM GROUP
128	YAAA AAA1 1000 0000	SET SHORT ADDRESS
129	YAAA AAA1 1000 0001	ENABLE WRITE MEMORY
130~143	—	Reserved
144	YAAA AAA1 1001 0000	QUERY STATUS
145	YAAA AAA1 1001 0001	QUERY CONTROL GEAR PRESENT
146	YAAA AAA1 1001 0010	QUERY LAMP FAILURE
147	YAAA AAA1 1001 0011	QUERY LAMP POWER ON
148	YAAA AAA1 1001 0100	QUERY LIMIT ERROR
149	YAAA AAA1 1001 0101	QUERY RESET STATE
150	YAAA AAA1 1001 0110	QUERY MISSING SHORT ADDRESS
151	YAAA AAA1 1001 0111	QUERY VERSION NUMBER
152	YAAA AAA1 1001 1000	QUERY CONTENT DTR0
153	YAAA AAA1 1001 1001	QUERY DEVICE TYPE
154	YAAA AAA1 1001 1010	QUERY PHYSICAL MINIMUM
155	YAAA AAA1 1001 1011	QUERY POWER FAILURE
156	YAAA AAA1 1001 1100	QUERY CONTENT DTR1
157	YAAA AAA1 1001 1101	QUERY CONTENT DTR2
158	YAAA AAA1 1001 1110	QUERY OPERATING MODE
159	YAAA AAA1 1001 1111	QUERY LIGHT SOURCE TYPE
160	YAAA AAA1 1010 0000	QUERY ACTUAL LEVEL
161	YAAA AAA1 1010 0001	QUERY MAX LEVEL
162	YAAA AAA1 1010 0010	QUERY MIN LEVEL
163	YAAA AAA1 1010 0011	QUERY POWER ON LEVEL
164	YAAA AAA1 1010 0100	QUERY SYSTEM FAILURE LEVEL
165	YAAA AAA1 1010 0101	QUERY FADE TIME /FADE RATE
166	YAAA AAA1 1010 0110	QUERY MANUFACTURER SPECIFIC MODE
167	YAAA AAA1 1010 0111	QUERY NEXT DEVICE TYPE
168	YAAA AAA1 1010 1000	QUERY EXTENDED FADE TIME
169	—	Reserved
170	YAAA AAA1 1010 1010	QUERY CONTROL GEAR FAILURE
171~175	—	Reserved
176~191	YAAA AAA1 1011 XXXX	QUERY SCENE LEVEL (SCENE 0~15)
192	YAAA AAA1 1100 0000	QUERY GROUPS 0~7
193	YAAA AAA1 1100 0001	QUERY GROUPS 8~15
194	YAAA AAA1 1100 0010	QUERY RANDOM ADDRESS (H)
195	YAAA AAA1 1100 0011	QUERY RANDOM ADDRESS (M)
196	YAAA AAA1 1100 0100	QUERY RANDOM ADDRESS (L)
197	YAAA AAA1 1100 0101	READ MEMORY LOCATION
198~223	—	Reserved
224~254	YAAA AAA1 111X XXXX	Refer to IEC62386-207/209 protocol commands
255	YAAA AAA1 1111 1111	QUERY EXTENDED VERSION NUMBER
256	1010 0001 0000 0000	TERMINAL
257	1010 0011 XXXX XXXX	DTR0
258	1010 0101 XXXX XXXX	INITIALISE

Command No.	Command Format	Command Name
259	1010 0111 0000 0000	RANDOMISE
260	1010 1001 0000 0000	COMPARE
261	1010 1011 0000 0000	WITHDRAW
262~263	—	Reserved
264	1011 0001 HHHH HHHH	SEARCHADDRH
265	1011 0011 MMMM MMMM	SEARCHADDRM
266	1011 0101 LLLL LLLL	SEARCHADDRL
267	1011 0111 0AAA AAA1	PROGRAM SHORT ADDRESS
268	1011 1001 0AAA AAA1	VERIFY SHORT ADDRESS
269	1011 1011 0000 0000	QUERY SHORT ADDRESS
270~271	—	Reserved
272	1100 0001 XXXX XXXX	ENABLE DEVICE TYPE
273	1100 0011 XXXX XXXX	DTR1
274	1100 0101 XXXX XXXX	DTR2
275	1100 0111 XXXX XXXX	WRITE MEMORY LOCATION
276	1100 1001 XXXX XXXX	WRITE MEMORY LOCATION – NO REPLY
277~299	—	Reserved

Reserved: There is no relevant command specified in the protocol or the module does not support the function.

IEC62386-207 ed2.0 Protocol Commands

Command No.	Command Format	Command Name
227	YAAA AAA1 1110 0011	SELECT DIMMING CURVE
228	YAAA AAA1 1110 0100	SET FAST FADE TIME
237	YAAA AAA1 1110 1101	QUERY CONTROL GEAR TYPE
238	YAAA AAA1 1110 1110	QUERY DIMMING CURVE
240	YAAA AAA1 1111 0000	QUERY FEATURES
241	YAAA AAA1 1111 0001	QUERY FAILURE STATUS
242	YAAA AAA1 1111 0010	QUERY SHORT CIRCUIT
243	YAAA AAA1 1111 0011	QUERY OPEN CIRCUIT
252	YAAA AAA1 1111 1100	QUERY OPERATING MODE
253	YAAA AAA1 1111 1101	QUERY FAST FADE TIME
254	YAAA AAA1 1111 1110	QUERY MIN FAST FADE TIME
255	YAAA AAA1 1111 1111	QUERY EXTENDED VERSION NUMBER
272	1100 0001 0000 0110	ENABLE DEVICE TYPE 6

IEC62386-209 ed1.0 Protocol Commands

Command No.	Command Format	Command Name
226	YAAA AAA1 1110 0010	ACTIVE
231	YAAA AAA1 1110 0111	SET TEMPORARY COLOUR TEMPERATURE T _c
232	YAAA AAA1 1110 1000	COLOUR TEMPERATURE T _c STEP COOLER
233	YAAA AAA1 1110 1001	COLOUR TEMPERATURE T _c STEP WARMER
238	YAAA AAA1 1110 1110	COPY REPORT TO TEMPORARY
239	YAAA AAA1 1110 1111	STORE COLOUR TEMPERATURE T _c INCREMENT
242	YAAA AAA1 1111 0010	STORE COLOUR TEMPERATURE T _c LIMIT
243	YAAA AAA1 1111 0011	STORE GEAR FEATURES/STATUS
247	YAAA AAA1 1111 0111	QUERY GEAR FEATURES/STATUS
248	YAAA AAA1 1111 1000	QUERY COLOUR STATUS
249	YAAA AAA1 1111 1001	QUERY COLOUR TYPE FEATURES

Command No.	Command Format	Command Name
250	YAAA AAA1 1111 1010	QUERY COLOUR VALUE
255	YAAA AAA1 1111 1111	QUERY EXTENDED VERSION NUMBER
272	1100 0001 0000 1000	ENABLE DEVICE TYPE 8

Note: The commands and functions supported by the module meet the requirements of the test software DALI Test sequence 2.4.0.0.

Application Circuits

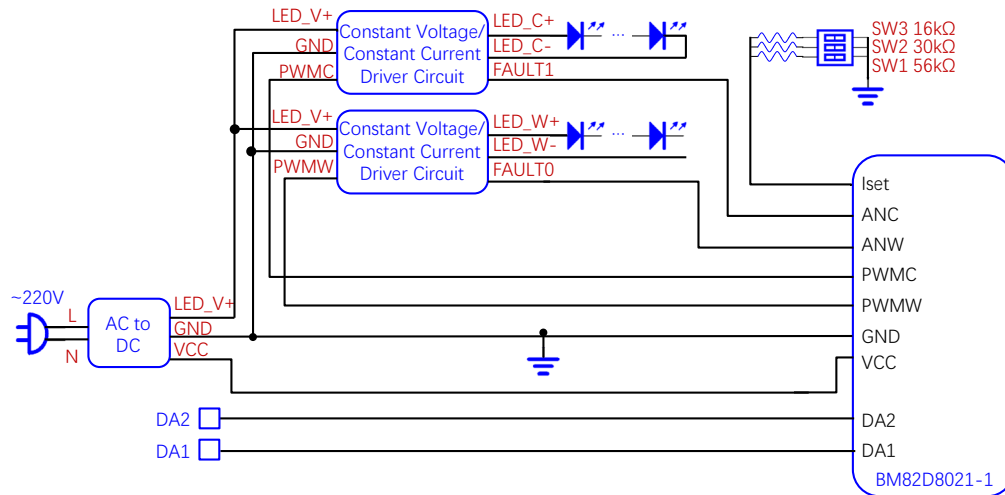

Layout Description

PCB Footprint

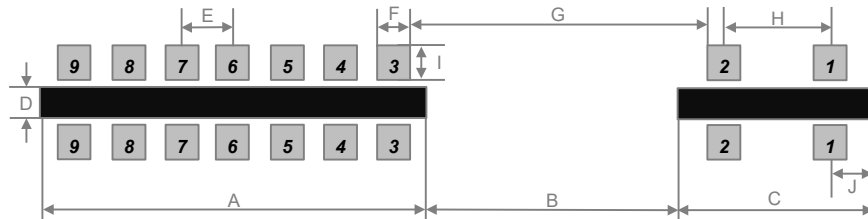

Symbol	Unit	mm	inch
A		18.74	0.738
B		11.68	0.460
C		9.58	0.377
D		1.10	0.043
E		2.54	0.100
F		1.50	0.059
G		14.18	0.558
H		5.08	0.200
I		1.50	0.059
J		2.25	0.089

Layout Guidelines

In order to have a safer operating environment for the module, it is recommended to keep a distance of 3mm or more between the DALI interface traces, and also keep a necessary safety distance from other traces, especially the high-voltage parts.

Dimensions

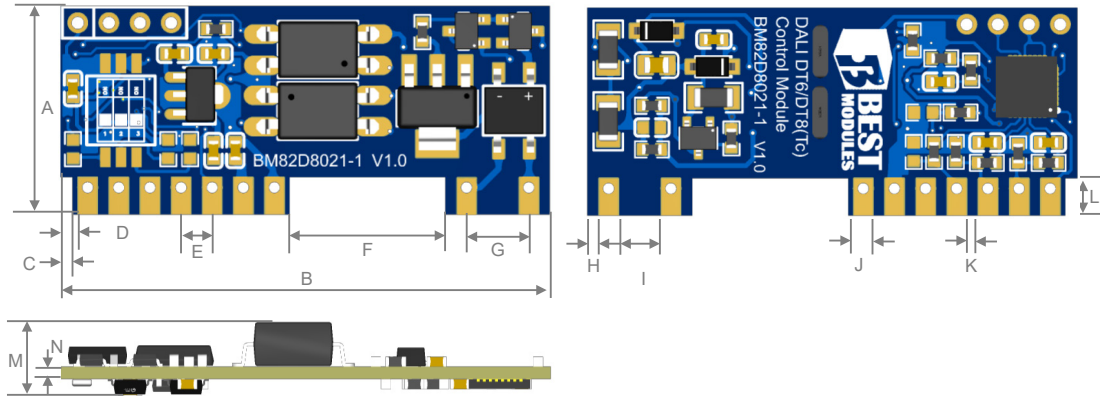

Symbol	Unit	mm	inch
A		17.00	0.669
B		40.00	1.575
C		1.00	0.039
D		1.50	0.059
E		2.54	0.100
F		12.68	0.499
G		5.08	0.200
H		1.00	0.039
I		3.58	0.141
J		1.50	0.059
K		1.04	0.041
L		3.05	0.120
M		6.50	0.256
N		1.00	0.039

Reference Information

Modification History

Data	Author	Issue	Modification Information
2024.04.17	葉啟華	V1.00	First Version
2024.06.24	葉啟華	V1.10	Add and modify some pin functions, modify the power-off data retention time, and add a note in the Supported Commands chapter.

Buy Online

[Best Modules](#)

Copyright© 2024 by BEST MODULES CORP. All Rights Reserved.

The information provided in this document has been produced with reasonable care and attention before publication, however, BEST MODULES does not guarantee that the information is completely accurate. The information contained in this publication is provided for reference only and may be superseded by updates. BEST MODULES disclaims any expressed, implied or statutory warranties, including but not limited to suitability for commercialization, satisfactory quality, specifications, characteristics, functions, fitness for a particular purpose, and non-infringement of any third-party's rights. BEST MODULES disclaims all liability arising from the information and its application. In addition, BEST MODULES does not recommend the use of BEST MODULES' products where there is a risk of personal hazard due to malfunction or other reasons. BEST MODULES hereby declares that it does not authorise the use of these products in life-saving, life-sustaining or safety critical components. Any use of BEST MODULES' products in life-saving/sustaining or safety applications is entirely at the buyer's risk, and the buyer agrees to defend, indemnify and hold BEST MODULES harmless from any damages, claims, suits, or expenses resulting from such use. The information provided in this document, including but not limited to the content, data, examples, materials, graphs, and trademarks, is the intellectual property of BEST MODULES (and its licensors, where applicable) and is protected by copyright law and other intellectual property laws. No license, express or implied, to any intellectual property right, is granted by BEST MODULES herein. BEST MODULES reserves the right to revise the information described in the document at any time without prior notice. For the latest information, please contact us.