



HT32F61355/HT32F61356/HT32F61357 Datasheet

**32-Bit Arm[®] Cortex[®]-M0+ Microcontroller
with 32-channel Music Synthesizer
up to 128 KB Flash, 16 KB SRAM and 32/64/128 Mbits
Flash Data Memory with Music Synthesis Engine (MIDI Engine)
DAC, 1 MSPS ADC, USART, UART, SPI, QSPI, I²C, I²S
GPTM, SCTM, BFTM, CRC, RTC, WDT and USB2.0 FS**

Revision: V1.10 Date: January 31, 2023

www.holtek.com

Table of Contents

| | |
|---|-----------|
| 1 General Description | 6 |
| 2 Development Tools | 7 |
| 3 Features | 7 |
| Core | 7 |
| On-chip Memory | 7 |
| Flash Memory Controller – FMC | 7 |
| Reset Control Unit – RSTCU | 8 |
| Clock Control Unit – CKCU | 8 |
| Power Management Control Unit – PWRCU | 8 |
| External Interrupt/Event Controller – EXTI | 9 |
| Analog to Digital Converter – ADC | 9 |
| I/O Ports – GPIO | 9 |
| PWM Generation and Capture Timers – GPTM | 10 |
| Single Channel Generation and Capture Timers – SCTM | 10 |
| Basic Function Timer – BFTM | 10 |
| Digital to Analog Converter – DAC | 11 |
| Music Synthesis Engine (MIDI Engine) – MSE | 11 |
| Watchdog Timer – WDT | 11 |
| Real Time Clock – RTC | 11 |
| Inter-integrated Circuit – I ² C | 12 |
| Inter-IC Sound – I ² S | 12 |
| Operation Divider – DIV | 12 |
| Serial Peripheral Interface – SPI | 13 |
| Quad Serial Peripheral Interface – QSPI | 13 |
| Universal Synchronous Asynchronous Receiver Transmitter – USART | 13 |
| Universal Asynchronous Receiver Transmitter – UART | 14 |
| Cyclic Redundancy Check – CRC | 14 |
| Universal Serial Bus Device Controller – USB | 15 |
| Peripheral Direct Memory Access – PDMA | 15 |
| SPI Flash Data Memory | 16 |
| Debug Support | 16 |
| Package and Operation Temperature | 16 |
| 4 Overview | 17 |
| Device Information | 17 |

| | |
|---|-----------|
| Block Diagram | 18 |
| Memory Map | 19 |
| Clock Structure | 22 |
| 5 SPI Flash Data Memory | 23 |
| Standard SPI Modes | 24 |
| Quad I/O SPI Modes | 24 |
| 6 Pin Assignment | 27 |
| 7 Application Block | 38 |
| 8 Application Circuits | 39 |
| 9 Electrical Characteristics | 40 |
| Absolute Maximum Ratings | 40 |
| Recommended DC Operating Conditions | 40 |
| On-Chip LDO Voltage Regulator Characteristics | 40 |
| Power Consumption | 41 |
| Reset and Supply Monitor Characteristics | 41 |
| External Clock Characteristics | 42 |
| Internal Clock Characteristics | 43 |
| PLL Characteristics | 44 |
| Memory Characteristics | 44 |
| I/O Port Characteristics | 44 |
| ADC Characteristics | 46 |
| SCTM/GPTM Characteristics | 47 |
| I ² C Characteristics | 47 |
| I ² S Characteristics | 48 |
| SPI Characteristics | 49 |
| QSPI Characteristics | 51 |
| USB Characteristics | 54 |
| Audio D/A Converter Characteristics | 55 |
| SPI Flash Data Memory DC Characteristics | 56 |
| 10 Package Information | 57 |
| 48-pin LQFP (7 mm × 7 mm) Outline Dimensions | 58 |
| 64-pin LQFP (7 mm × 7 mm) Outline Dimensions | 59 |

List of Tables

| | |
|---|----|
| Table 1. Features and Peripheral List | 17 |
| Table 2. Register Map | 20 |
| Table 3. HT32F61355/HT32F61356 48/64-pin LQFP Package | 31 |
| Table 4. HT32F61357 48/64-pin LQFP Package | 32 |
| Table 5. HT32F61355/HT32F61356 Pin Description | 34 |
| Table 6. HT32F61357 Pin Description | 36 |
| Table 7. Absolute Maximum Ratings | 40 |
| Table 8. Recommended DC Operating Conditions | 40 |
| Table 9. LDO Characteristics | 40 |
| Table 10. Power Consumption Characteristics | 41 |
| Table 11. V _{DD} Power Reset Characteristics | 41 |
| Table 12. LVD/BOD Characteristics | 42 |
| Table 13. High Speed External Clock (HSE) Characteristics | 42 |
| Table 14. Low Speed External Clock (LSE) Characteristics | 43 |
| Table 15. High Speed Internal Clock (HSI) Characteristics | 43 |
| Table 16. Low Speed Internal Clock (LSI) Characteristics | 44 |
| Table 17. PLL Characteristics | 44 |
| Table 18. Flash Memory Characteristics | 44 |
| Table 19. I/O Port Characteristics | 44 |
| Table 20. ADC Characteristics | 46 |
| Table 21. SCTM/GPTM Characteristics | 47 |
| Table 22. I ² C Characteristics | 47 |
| Table 23. I ² S Characteristics | 48 |
| Table 24. SPI Characteristics | 49 |
| Table 25. QSPI Characteristics | 51 |
| Table 26. USB DC Electrical Characteristics | 54 |
| Table 27. USB AC Electrical Characteristics | 55 |
| Table 28. Audio D/A Converter Characteristics | 55 |
| Table 29. SPI Flash Data Memory DC Characteristics | 56 |

List of Figures

| | |
|--|----|
| Figure 1. Block Diagram | 18 |
| Figure 2. Memory Map..... | 19 |
| Figure 3. Clock Structure | 22 |
| Figure 4. HT32F61355/61356 48-pin LQFP Pin Assignment..... | 27 |
| Figure 5. HT32F61355/61356 64-pin LQFP Pin Assignment..... | 28 |
| Figure 6. HT32F61357 48-pin LQFP Pin Assignment..... | 29 |
| Figure 7. HT32F61357 64-pin LQFP Pin Assignment..... | 30 |
| Figure 8. ADC Sampling Network Model | 46 |
| Figure 9. I ² C Timing Diagrams | 48 |
| Figure 10. Timing of I ² S Master Mode | 48 |
| Figure 11. Timing of I ² S Slave Mode..... | 49 |
| Figure 12. SPI Timing Diagrams – SPI Master Mode | 50 |
| Figure 13. SPI Timing Diagrams – SPI Slave Mode with CPHA = 1 | 50 |
| Figure 14. QSPI Timing Diagrams – QSPI Master Mode (1-bit Serial Mode, DUALEN = 0, QUADEN = 0) | 52 |
| Figure 15. QSPI Timing Diagrams – QSPI Master Mode (Dual Mode, DUALEN = 1)..... | 52 |
| Figure 16. QSPI Timing Diagrams – QSPI Master Mode (Quad Mode, QUADEN = 1)..... | 53 |
| Figure 17. QSPI Timing Diagrams – QSPI Slave Mode with CPHA = 1 (1-bit Serial Mode)..... | 54 |
| Figure 18. USB Signal Rise Time and Fall Time and Cross-Point Voltage (V_{CRS}) Definition | 55 |

1 General Description

These devices are high performance, low power consumption 32-bit microcontrollers based around an Arm® Cortex®-M0+ processor core. The Cortex®-M0+ is a next-generation processor core which is tightly coupled with Nested Vectored Interrupt Controller (NVIC), SysTick timer and including advanced debug support.

The devices operate at a frequency of up to 48 MHz with a Flash accelerator to obtain maximum efficiency. They provide up to 128 KB of embedded Flash memory for code/data storage and 16 KB of embedded SRAM memory for system operation and application program usage. A variety of peripherals, such as ADC, 2-channel DAC, I²C, I²S, USART, UART, SPI, QSPI, GPTM, SCTM, CRC-16/32, RTC, WDT, USB2.0 FS, 32-channel music synthesizer, SW-DP (Serial Wire Debug Port), etc., are also implemented in the devices. Several power saving modes provide the flexibility for maximum optimization between wakeup latency and power consumption, an especially important consideration in low power applications.

The devices integrate Wave Table synthesis function. They can operate up to 32 channels of Wave Table synthesis at one time and control the MIDI Engine to generate melody by setting the special registers. The Wave Table synthesis waveform data including instrument tone, MIDI scores, voice, sound effect, etc., are stored in the internal SPI Flash Data Memory. With these features, the devices provide enhanced functions and higher performance.

The above features ensure that the devices are suitable for use in a wide range of applications, especially in areas such as electronic organs, digital pianos, electronic drums, electric guitars, electric accordions and so on.

arm CORTEX

2 Development Tools

For rapid product development and to simplify device parameter setting, Holtek has provided relevant development tools which users can download from the following link:

<https://www.holtek.com/audio-workshop>

3 Features

Core

- 32-bit Arm® Cortex®-M0+ processor core
- Up to 48 MHz operating frequency
- 0.93 DMIPS / MHz (Dhrystone v2.1)
- Single-cycle multiplication
- Integrated Nested Vectored Interrupt Controller (NVIC)
- 24-bit SysTick timer

The Cortex®-M0+ processor is a very low gate count, highly energy efficient processor that is intended for microcontrollers and deeply embedded applications that require an area optimized, low-power processor. The processor is based on the Armv6-M architecture and supports Thumb® instruction sets; single-cycle I/O port; hardware multiplier and low latency interrupt respond time.

On-chip Memory

- Up to 128 KB on-chip Flash memory for instruction/data and options storage
- 16 KB on-chip SRAM
- Supports multiple boot modes

The Arm® Cortex®-M0+ processor accesses and debug accesses share the single external interface to external AHB peripheral. The processor accesses take priority over debug accesses. The maximum address range of the Cortex®-M0+ is 4 GB since it has a 32-bit bus address width. Additionally, a pre-defined memory map is provided by the Cortex®-M0+ processor to reduce the software complexity of repeated implementation by different device vendors. However, some regions are used by the Arm® Cortex®-M0+ system peripherals. Refer to the Arm® Cortex®-M0+ Technical Reference Manual for more information.

Flash Memory Controller – FMC

- Flash accelerator for maximum efficiency
- 32-bit word programming with In System Programming Interface (ISP) and In Application Programming (IAP)

- Flash protection capability to prevent illegal access

The Flash Memory Controller, FMC, provides all the necessary functions and pre-fetch buffer for the embedded on-chip Flash Memory. Since the access speed of the Flash Memory is slower than the CPU, a wide access interface with a pre-fetch buffer and cache are provided for the Flash Memory in order to reduce the CPU waiting time which will cause CPU instruction execution delays. Flash Memory word program/page erase functions are also provided.

Reset Control Unit – RSTCU

- Supply supervisor:
 - Power on Reset / Power down Reset – POR/PDR
 - Brown-out Detector – BOD
 - Programmable Low Voltage Detector – LVD

The Reset Control Unit, RSTCU, has three kinds of reset, a power on reset, a system reset and an APB unit reset. The power on reset, known as a cold reset, resets the full system during power up. A system reset resets the processor core and peripheral IP components with the exception of the SW-DP controller. The resets can be triggered by an external signal, internal events and the reset generators.

Clock Control Unit – CKCU

- External 4 to 16 MHz crystal oscillator
- External 32,768 Hz crystal oscillator
- Internal 8 MHz RC oscillator trimmed to $\pm 2\%$ accuracy at 3.3 V operating voltage and 25 °C operating temperature
- Internal 32 kHz RC oscillator
- Integrated system clock PLL
- Independent clock divider and gating bits for peripheral clock sources

The Clock Control unit, CKCU, provides a range of oscillator and clock functions. These include a High Speed Internal RC oscillator (HSI), a High Speed External crystal oscillator (HSE), a Low Speed Internal RC oscillator (LSI), a Low Speed External crystal oscillator (LSE), a Phase Lock Loop (PLL), an HSE clock monitor, clock prescalers, clock multiplexers, APB clock divider and gating circuitry. The AHB, APB and Cortex®-M0+ clocks are derived from the system clock (CK_SYS) which can come from the LSI, LSE, HSI, HSE or PLL. The Watchdog Timer and Real Time Clock (RTC) use either the LSI or LSE as their clock source.

Power Management Control Unit – PWRCU

- Single V_{DD} power supply: 2.0 V to 3.6 V
- Integrated 1.5 V LDO regulator for CPU core, peripherals and memories power supply
- V_{DD} power supply for RTC
- Two power domains: V_{DD} , 1.5 V
- Four power saving modes: Sleep, Deep-Sleep1, Deep-Sleep2, Power-Down

Power consumption can be regarded as one of the most important issues for many embedded system applications. Accordingly the Power Control Unit, PWRCU, in the devices provides many types of power saving modes such as Sleep, Deep-Sleep1, Deep-Sleep2 and Power-Down mode. These operating modes reduce the power consumption and allow the application to achieve the best trade-off between the conflicting demands of CPU operating time, speed and power consumption.

External Interrupt/Event Controller – EXTI

- Up to 16 EXTI lines with configurable trigger source and type
- All GPIO pins can be selected as EXTI trigger source
- Source trigger type includes high level, low level, negative edge, positive edge or both edge
- Individual interrupt enable, wakeup enable and status bits for each EXTI line
- Software interrupt trigger mode for each EXTI line
- Integrated deglitch filter for short pulse blocking

The External Interrupt/Event Controller, EXTI, comprises 16 edge detectors which can generate a wake-up event or interrupt requests independently. Each EXTI line can also be masked independently.

Analog to Digital Converter – ADC

- 12-bit SAR ADC engine
- Up to 1 Msps conversion rate
- Up to 16 external analog input channels

A 12-bit multi-channel ADC is integrated in the devices. There are multiplexed channels, which include 16 external analog signal channels and 2 internal channels which can be measured. If the input voltage is required to remain within a specific threshold window, an Analog Watchdog function will monitor and detect these signals. An interrupt will then be generated to inform the device that the input voltage is not within the preset threshold levels. There are three conversion modes to convert an analog signal to digital data. The ADC can be operated in one shot, continuous and discontinuous conversion modes.

I/O Ports – GPIO

- Up to 43 GPIOs
- Port A, B, C, D are mapped as 16 external interrupts – EXTI
- Almost all I/O pins have a configurable output driving current.

There are up to 43 General Purpose I/O pins, GPIO for the implementation of logic input/output functions. Each of the GPIO ports has a series of related control and configuration registers to maximize flexibility and to meet the requirements of a wide range of applications.

The GPIO ports are pin-shared with other alternative functions to obtain maximum functional flexibility on the package pins. The GPIO pins can be used as alternative functional pins by configuring the corresponding registers regardless of the input or output pins. The external interrupts on the GPIO pins of the devices have related control and configuration registers in the External Interrupt Control Unit, EXTI.

PWM Generation and Capture Timers – GPTM

- One 16-bit up, down, up/down auto-reload counter
- 16-bit programmable prescaler allowing counter clock frequency division by any factor between 1 and 65536
- Input Capture function
- Compare Match Output
- PWM waveform generation with Edge-aligned and Center-aligned Counting Modes
- Single Pulse Mode Output
- Encoder interface controller with two inputs using quadrature decoder

The General Purpose Timer consists of one 16-bit up/down-counter, four 16-bit Capture/Compare Registers (CCRs), one 16-bit Counter Reload Register (CRR) and several control/status registers. They can be used for a variety of purposes including general time measurement, input signal pulse width measurement, output waveform generation such as single pulse generation or PWM output generation. The GPTM supports an Encoder Interface using a decoder with two inputs.

Single Channel Generation and Capture Timers – SCTM

- One 16-bit up and auto-reload counter
- One channel for each timer
- 16-bit programmable prescaler allowing counter clock frequency division by any factor between 1 and 65536
- Input Capture function
- Compare Match Output
- PWM waveform generation with Edge-aligned
- Single Pulse Mode Output

The Single-Channel Timer consists of one 16-bit up-counter, one 16-bit Capture/Compare Register (CCR), one 16-bit Counter-Reload Register (CRR) and several control/status registers. It can be used for a variety of purposes including general timer, input signal pulse width measurement or output waveform generation such as single pulse generation or PWM output.

Basic Function Timer – BFTM

- One 32-bit compare/match count-up counter – no I/O control features
- One shot mode – counting stops after a match condition
- Repetitive mode – restart counter after a match condition

The Basic Function Timer is a simple count-up 32-bit counter designed to measure time intervals and generate a one shot or repetitive interrupts. The BFTM operates in two functional modes, repetitive or one shot mode. In the repetitive mode the BFTM restarts the counter when a compare match event occurs. The BFTM also supports a one shot mode which forces the counter to stop counting when a compare match event occurs.

Digital to Analog Converter – DAC

- Two 16-bit high resolution D/A converters with excellent frequency response characteristics and good power consumption for stereo audio output.

Music Synthesis Engine (MIDI Engine) – MSE

- Up to 32 simultaneous sounds
- 10-bit Volume Control
- Output sampling frequency up to 50 kHz
- Waveform data lengths of 8, 12 or 16 bits
- Stereo output
- Supports Repeat loop Play
- Supports PDMA interface

Watchdog Timer – WDT

- 12-bit down counter with 3-bit prescaler
- Reset event for the system
- Programmable watchdog timer window function
- Register write protection function

The Watchdog Timer is a hardware timing circuit that can be used to detect system failures due to software malfunctions. It includes a 12-bit count-down counter, a prescaler, a WDT delta value register, WDT operation control circuitry and a WDT protection mechanism. If the software does not reload the counter value before a Watchdog Timer underflow occurs, a reset will be generated when the counter underflows. In addition, a reset is also generated if the software reloads the counter when the counter value is greater than the WDT delta value. This means the counter must be reloaded within a limited timing window using a specific method. The Watchdog Timer counter can be stopped while the processor is in the debug mode. There is a register write protect function which can be enabled to prevent it from changing the Watchdog Timer configuration unexpectedly.

Real Time Clock – RTC

- 32-bit up-counter with a programmable prescaler
- Alarm function
- Interrupt and Wake-up event

The Real Time Clock, RTC, includes an APB interface, a 32-bit count-up counter, a control register, a prescaler, a compare register and a status register. Most of the RTC circuits are located in the V_{DD} Domain except for the APB interface. The APB interface is located in the V_{DD15} power domain. Therefore, it is necessary to be isolated from the ISO signal that comes from the power control unit when the V_{DD15} power domain is powered off, that is when the device enters the Power-Down mode. The RTC counter is used as a wakeup timer to generate a system resume signal from the Power-Down mode.

Inter-integrated Circuit – I²C

- Supports both master and slave modes with a frequency of up to 1 MHz
- Provides an arbitration function and clock synchronization
- Supports 7-bit and 10-bit addressing modes and general call addressing
- Supports slave multi-addressing mode with maskable address

The I²C is an internal circuit allowing communication with an external I²C interface which is an industry standard two line serial interface used for connection to external hardware. These two serial lines are known as a serial data line, SDA, and a serial clock line, SCL. The I²C module provides three data transfer rates: (1) 100 kHz in the Standard mode, (2) 400 kHz in the Fast mode and (3) 1 MHz in the Fast plus mode. The SCL period generation register is used to setup different kinds of duty cycle implementations for the SCL pulse.

The SDA line which is connected directly to the I²C bus is a bi-directional data line between the master and slave devices and is used for data transmission and reception. The I²C also has an arbitration detect function and clock synchronization to prevent situations where more than one master attempts to transmit data to the I²C bus at the same time.

Inter-IC Sound – I²S

- Master or slave mode
- Mono and stereo
- I²S-justified, Left-justified and Right-justified mode
- 8 / 16 / 24 / 32-bit sample size with 32-bit channel extended
- 8 × 32-bit TX & RX FIFO with PDMA supported
- 8-bit Fractional Clock Divider with rate control

The I²S is a synchronous communication interface that can be used as a master or slave to exchange data with other audio peripherals, such as ADCs or DACs. The I²S supports a variety of data formats. In addition to the stereo I²S-justified, Left-justified and Right-justified modes, there are mono PCM modes with 8 / 16 / 24 / 32-bit sample size. When the I²S operates in the master mode, then when using the fractional divider, it can provide an accurate sampling frequency output and support the rate control function and fine-tuning of the output frequency to avoid system problems caused by the cumulative frequency error between different devices.

Operation Divider – DIV

- Signed/unsigned 32-bit divider
- Operation in 8 clock cycles, Load in 1 clock cycle
- Divide by zero error flag

In order to enhance MCU performance, a Divider is implemented within the devices. The division and modulus functions of the truncated division are related in the following way:

$$A / B = Q \dots R$$

Where “A” is Dividend, “B” is Divisor, “Q” is Quotient and “R” is Remainder. Divider needs software trigger start signal by using the control register “START” bit, after 8 clock cycles, the divider calculate complete flag will be set to 1, but if divisor register data is zero, divide 0 error flag will be set to 1.

Serial Peripheral Interface – SPI

- Supports both master and slave mode
- Frequency of up to ($f_{PCLK}/2$) MHz for the master mode and ($f_{PCLK}/3$) MHz for the slave mode
- FIFO Depth: 8 levels
- Multi-master and multi-slave operation

The Serial Peripheral Interface, SPI, provides an SPI protocol data transmit and receive function in both master and slave mode. The SPI interface uses 4 pins, which are the serial data input and output lines MISO and MOSI, the clock line, SCK, and the slave select line, SEL. One SPI device acts as a master device which controls the data flow using the SEL and SCK signals to indicate the start of data communication and the data sampling rate. To receive a data byte, the streamed data bits are latched on a specific clock edge and stored in the data register or in the RX FIFO. Data transmission is carried out in a similar way but in a reverse sequence. The mode fault detection provides a capability for multi-master applications.

Quad Serial Peripheral Interface – QSPI

- Master or slave mode
- Master mode speed up to $f_{HCLK}/2$
- Slave mode speed up to $f_{HCLK}/3$
- Programmable data frame length up to 16 bits
- FIFO Depth: 8 levels
- MSB or LSB first shift selection
- Programmable slave select high or low active polarity
- Multi-master and multi-slave operation
- Master mode supports the dual/quad output read mode of QSPI series NOR Flash
- Four error flags with individual interrupt
 - Read overrun
 - Write collision
 - Mode fault
 - Slave abort
- Supports PDMA interface

The Quad Serial Peripheral Interface, QSPI, provides a QSPI protocol data transmit and receive functions in both master or slave mode. The QSPI interface uses 6 pins for Dual/Quad SPI, among which are serial data input and output lines SIO3, SIO2, MISO/SIO1 and MOSI/SIO0, the clock line SCK, and the slave select line SEL.

Universal Synchronous Asynchronous Receiver Transmitter – USART

- Supports both asynchronous and clocked synchronous serial communication modes
- Asynchronous operating baud rate up to ($f_{PCLK}/16$) MHz and synchronous operating rate up to ($f_{PCLK}/8$) MHz
- Full duplex communication

- Fully programmable serial communication characteristics including:
 - Word length: 7, 8 or 9-bit character
 - Parity: Even, odd or no-parity bit generation and detection
 - Stop bit: 1 or 2 stop bit generation
 - Bit order: LSB-first or MSB-first transfer
- Error detection: Parity, overrun and frame error
- Auto hardware flow control mode – RTS, CTS
- IrDA SIR encoder and decoder
- RS485 mode with output enable control
- FIFO Depth: 8×9 bits for both receiver and transmitter

The Universal Synchronous Asynchronous Receiver Transceiver, USART, provides a flexible full duplex data exchange using synchronous or asynchronous data transfer. The USART is used to translate data between parallel and serial interfaces, and is commonly used for RS232 standard communication. The USART peripheral function supports four types of interrupt including Line Status Interrupt, Transmitter FIFO Empty Interrupt, Receiver Threshold Level Reaching Interrupt and Time Out Interrupt. The USART module includes a transmitter FIFO, TX FIFO, and receiver FIFO, RX FIFO. The software can detect a USART error status by reading the Line Status Register, LSR. The status includes the type and the condition of transfer operations as well as several error conditions resulting from Parity, Overrun, Framing and Break events.

Universal Asynchronous Receiver Transmitter – UART

- Asynchronous serial communication operating baud rate up to $f_{\text{PCLK}}/16$ MHz
- Full duplex communication
- Fully programmable serial communication characteristics including:
 - Word length: 7, 8 or 9-bit character
 - Parity: Even, odd or no-parity bit generation and detection
 - Stop bit: 1 or 2 stop bit generation
 - Bit order: LSB-first or MSB-first transfer
- Error detection: Parity, overrun and frame error

The Universal Asynchronous Receiver Transceiver, UART, provides a flexible full duplex data exchange using asynchronous transfer. The UART is used to translate data between parallel and serial interfaces, and is commonly used for RS232 standard communication. The UART peripheral function supports Line Status Interrupt. The software can detect a UART error status by reading the Line Status Register, LSR. The status includes the type and the condition of transfer operations as well as several error conditions resulting from Parity, Overrun, Framing and Break events.

Cyclic Redundancy Check – CRC

- Supports CRC16 polynomial: 0x8005,
 $X^{16} + X^{15} + X^2 + 1$
- Supports CCITT CRC16 polynomial: 0x1021,
 $X^{16} + X^{12} + X^5 + 1$
- Supports IEEE-802.3 CRC32 polynomial: 0x04C11DB7,
 $X^{32} + X^{26} + X^{23} + X^{22} + X^{16} + X^{12} + X^{11} + X^{10} + X^8 + X^7 + X^5 + X^4 + X^2 + X + 1$

- Supports 1's complement, byte reverse & bit reverse operation on data and checksum
- Supports byte, half-word & word data size
- Programmable CRC initial seed value
- CRC computation executed in 1 AHB clock cycle for 8-bit data and 4 AHB clock cycles for 32-bit data
- Supports PDMA to complete a CRC computation of a block of memory

The CRC calculation unit is an error detection technique test algorithm which is used to verify data transmission or storage data correctness. A CRC calculation takes a data stream or a block of data as its input and generates a 16-bit or 32-bit output remainder. Ordinarily, a data stream is suffixed by a CRC code and used as a checksum when being sent or stored. Therefore, the received or restored data stream is calculated by the same generator polynomial as described above. If the new CRC code result does not match the one calculated earlier, then this means that the data stream contains a data error.

Universal Serial Bus Device Controller – USB

- Complies with USB 2.0 full-speed (12 Mbps) specification
- On-chip USB full-speed transceiver
- 1 control endpoint (EP0) for control transfer
- 3 single-buffered endpoints (EP1 ~ EP3) for bulk and interrupt transfer
- 4 double-buffered endpoints (EP4 ~ EP7) for bulk, interrupt and isochronous transfer
- 1,024 bytes EP_SRAM used as the endpoint data buffers

The USB device controller is compliant with the USB 2.0 full-speed specification. There is one control endpoint known as Endpoint 0 and seven configurable endpoints. A 1024-byte SRAM is used as the endpoint buffer. Each endpoint buffer size is programmable using corresponding registers, which provides maximum flexibility for various applications. The integrated USB full-speed transceiver helps to minimize the overall system complexity and cost. The USB functional block also contains the resume and suspend feature to meet the requirements of low-power consumption.

Peripheral Direct Memory Access – PDMA

- 6 channels with trigger source grouping
- 8 / 16 / 32-bit width data transfer
- Supports Linear address, circular address and fixed address modes
- 4-level programmable channel priority
- Auto reload mode
- Supports trigger source: ADC, SPI, QSPI, USART, UART, I²C, I²S, GPTM, MIDI Engine and software request

The Peripheral Direct Memory Access controller, PDMA, moves data between the peripherals and the system memory on the AHB bus. Each PDMA channel has a source address, destination address, block length and transfer count. The PDMA can exclude the CPU intervention and avoid interrupt service routine execution. It improves system performance as the software does not need to join each data movement operation.

SPI Flash Data Memory

- Full voltage range: 2.3 V ~ 3.6 V
- Serial Interface Architecture
- SPI compatible: Mode 0 and Mode 3
- 256 bytes per programmable page
- Standard, Dual or Quad SPI modes
- Low power consumption
- Uniform Sector Architecture
- Any sector or block can be erased individually
- Software and Hardware Reset
- Read Unique ID Number

The Flash data memory is a 32 / 64 / 128 Mbits Serial Flash memory, with advanced write protection mechanisms. The devices support the single bit and four bits serial input and output commands via standard Serial Peripheral Interface (SPI) pins: Serial Clock, Chip Select, Serial DQ0 (DI) and DQ1(DO), DQ2 and DQ3. The memory can be programmed 1 to 256 bytes each time, using the Page Program instruction.

The devices also offer a sophisticated method for protecting individual blocks against erroneous or malicious program and erase operations. By providing the ability to individually protect and unprotect blocks, a system can unprotect a specific block to modify its contents while keeping the remaining blocks of the memory array securely protected.

Debug Support

- Serial Wire Debug Port – SW-DP
- 4 comparators for hardware breakpoint or code / literal patch
- 2 comparators for hardware watch points

Package and Operation Temperature

- 48 / 64-pin LQFP (7 mm × 7 mm)
- Operation temperature range: -40 °C to +85 °C

4 Overview

Device Information

Table 1. Features and Peripheral List

| Peripherals | | HT32F61355 | HT32F61356 | HT32F61357 |
|-------------------------|------------------|------------------|------------|------------|
| Main Flash (KB) | | 127.5 | | |
| Option Bytes Flash (KB) | | 0.5 | | |
| SRAM (KB) | | 16 | | |
| Timers | GPTM | 1 | | |
| | SCTM | 4 | | |
| | BFTM | 2 | | |
| | RTC | 1 | | |
| | WDT | 1 | | |
| Communication | USB | 1 | | |
| | SPI | 1 | | |
| | QSPI | 1 | | |
| | USART | 1 | | |
| | UART | 1 | | |
| | I ² C | 1 | | |
| | I ² S | 1 | | |
| PDMA | | 6 Channels | | |
| Hardware Divider | | 1 | | |
| CRC-16 / 32 | | 1 | | |
| EXTI | | 16 | | |
| 12-bit ADC | | 1 | | |
| Number of channels | | 16 Channels | | |
| Music Synthesis Engine | | 32 Channels | | |
| 16-bit DAC | | 2 Channels | | |
| SPI Flash Data Memory | | 32 Mbits | 64 Mbits | 128 Mbits |
| GPIO | | Up to 43 | | |
| CPU frequency | | Up to 48 MHz | | |
| Operating voltage | | 2.0 V ~ 3.6 V | | |
| Operating temperature | | -40 °C ~ +85 °C | | |
| Package | | 48 / 64-pin LQFP | | |

Note: The functions listed here, except the SPI Flash Data Memory, are compatible with the HT32F0006 device. Refer to the HT32F0006 user manual for detailed functional description.

Block Diagram

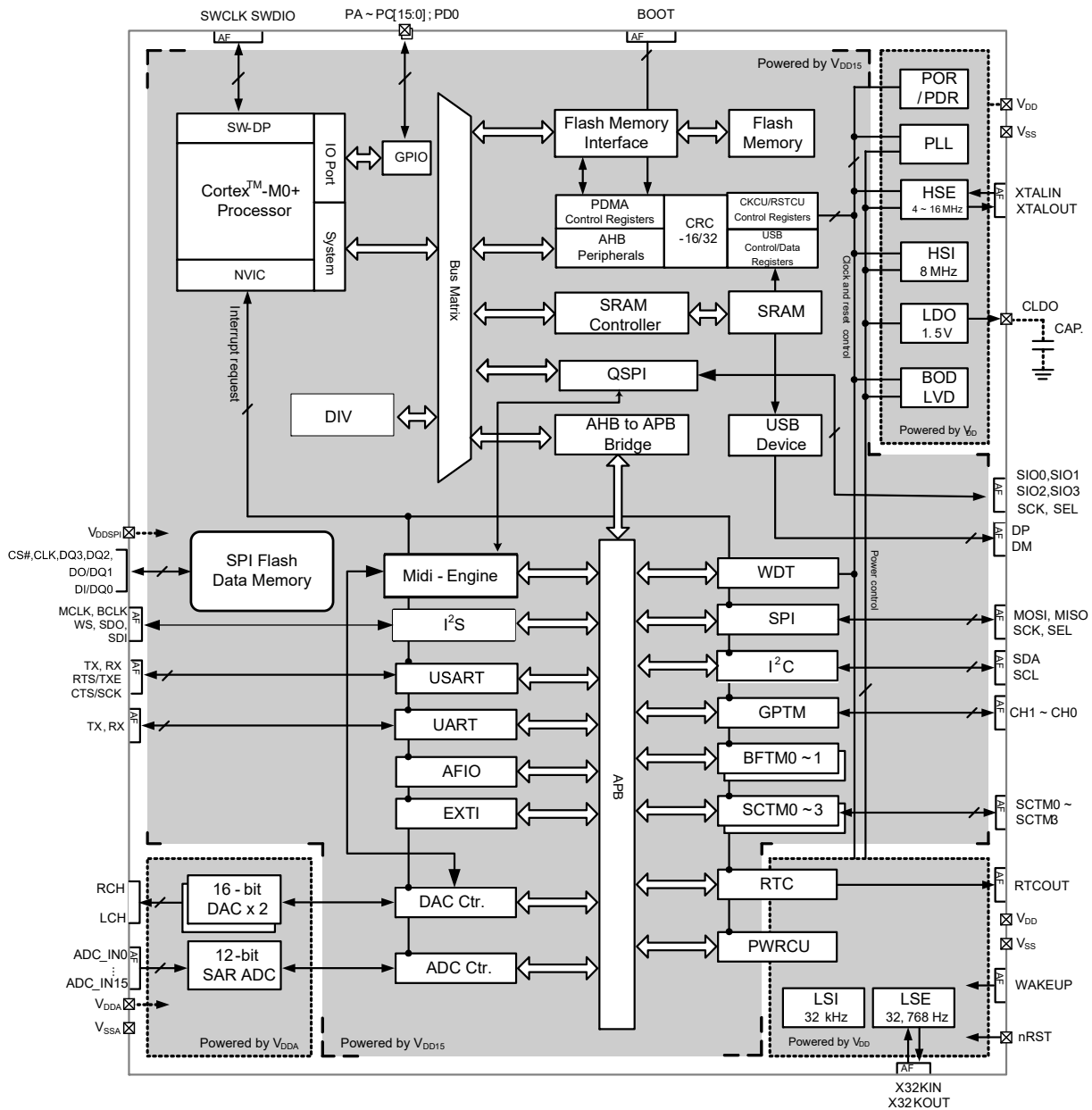

Figure 1. Block Diagram

Memory Map

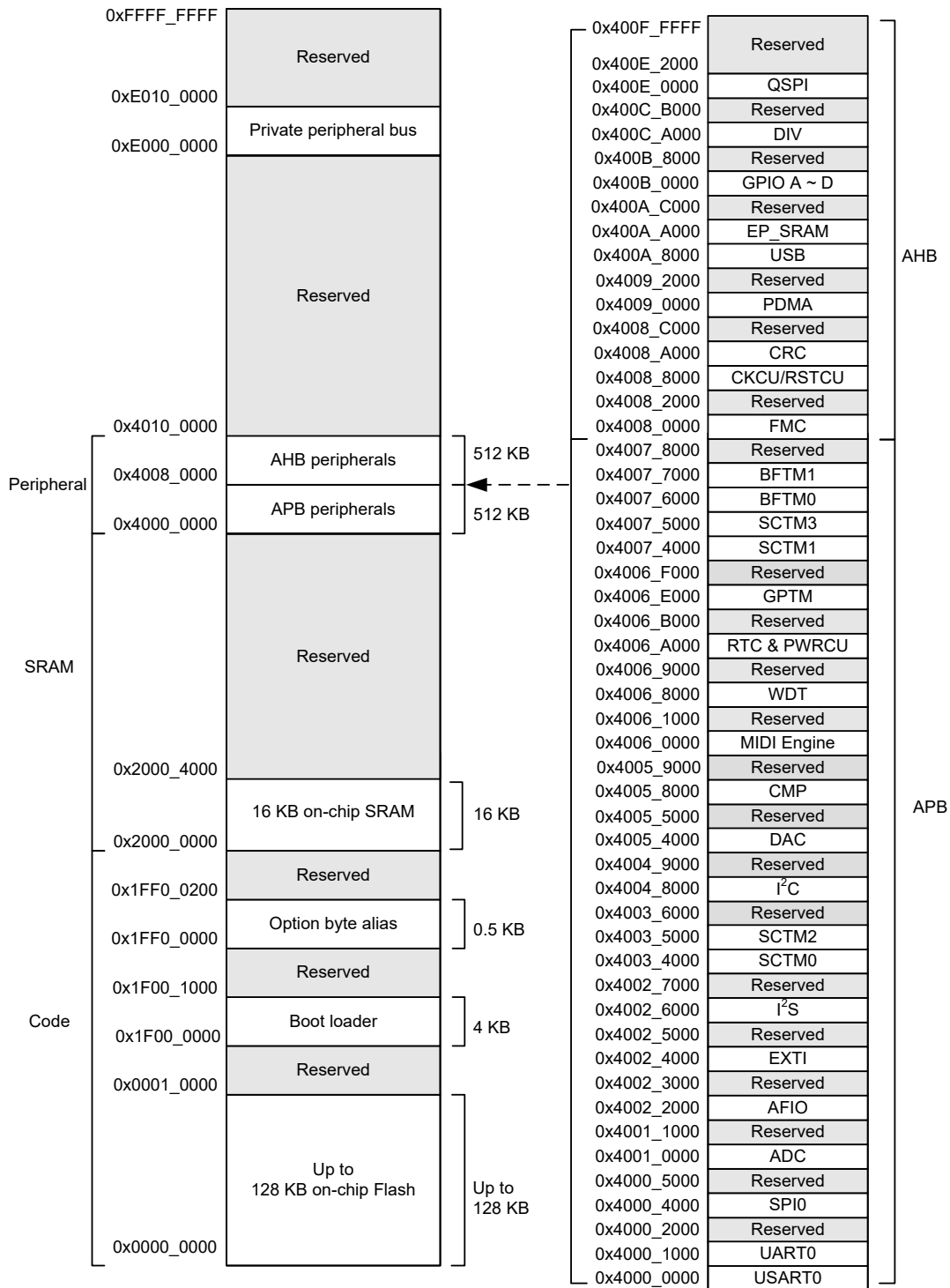

Figure 2. Memory Map

Table 2. Register Map

| Start Address | End Address | Peripheral | Bus |
|---------------|-------------|------------------|-----|
| 0x4000_0000 | 0x4000_0FFF | USART0 | APB |
| 0x4000_1000 | 0x4000_1FFF | UART0 | |
| 0x4000_2000 | 0x4000_3FFF | Reserved | |
| 0x4000_4000 | 0x4000_4FFF | SPI0 | |
| 0x4000_5000 | 0x4000_FFFF | Reserved | |
| 0x4001_0000 | 0x4001_0FFF | ADC | |
| 0x4001_1000 | 0x4002_1FFF | Reserved | |
| 0x4002_2000 | 0x4002_2FFF | AFIO | |
| 0x4002_3000 | 0x4002_3FFF | Reserved | |
| 0x4002_4000 | 0x4002_4FFF | EXTI | |
| 0x4002_5000 | 0x4002_5FFF | Reserved | |
| 0x4002_6000 | 0x4002_6FFF | I ² S | |
| 0x4002_7000 | 0x4003_3FFF | Reserved | |
| 0x4003_4000 | 0x4003_4FFF | SCTM0 | |
| 0x4003_5000 | 0x4003_5FFF | SCTM2 | |
| 0x4003_6000 | 0x4004_7FFF | Reserved | |
| 0x4004_8000 | 0x4004_8FFF | I ² C | |
| 0x4004_9000 | 0x4005_3FFF | Reserved | |
| 0x4005_4000 | 0x4005_4FFF | DAC | |
| 0x4005_5000 | 0x4005_7FFF | Reserved | |
| 0x4005_8000 | 0x4005_8FFF | Comparator | |
| 0x4005_9000 | 0x4005_FFFF | Reserved | |
| 0x4006_0000 | 0x4006_0FFF | MIDI Engine | |
| 0x4006_1000 | 0x4006_7FFF | Reserved | |
| 0x4006_8000 | 0x4006_8FFF | WDT | |
| 0x4006_9000 | 0x4006_9FFF | Reserved | |
| 0x4006_A000 | 0x4006_AFFF | RTC&PWRCU | |
| 0x4006_B000 | 0x4006_DFFF | Reserved | |
| 0x4006_E000 | 0x4006_EFFF | GPTM | |
| 0x4006_F000 | 0x4007_3FFF | Reserved | |
| 0x4007_4000 | 0x4007_4FFF | SCTM1 | |
| 0x4007_5000 | 0x4007_5FFF | SCTM3 | |
| 0x4007_6000 | 0x4007_6FFF | BFTM0 | |
| 0x4007_7000 | 0x4007_7FFF | BFTM1 | |
| 0x4007_8000 | 0x4007_FFFF | Reserved | |

| Start Address | End Address | Peripheral | Bus |
|---------------|-------------|------------------------|-----|
| 0x4008_0000 | 0x4008_1FFF | FMC | AHB |
| 0x4008_2000 | 0x4008_7FFF | Reserved | |
| 0x4008_8000 | 0x4008_9FFF | CKCU/RSTCU | |
| 0x4008_A000 | 0x4008_BFFF | CRC | |
| 0x4008_C000 | 0x4008_FFFF | Reserved | |
| 0x4009_0000 | 0x4009_1FFF | PDMA Control Registers | |
| 0x4009_2000 | 0x400A_7FFF | Reserved | |
| 0x400A_8000 | 0x400A_BFFF | USB | |
| 0x400A_C000 | 0x400A_FFFF | Reserved | |
| 0x400B_0000 | 0x400B_1FFF | GPIOA | |
| 0x400B_2000 | 0x400B_3FFF | GPIOB | |
| 0x400B_4000 | 0x400B_5FFF | GPIOC | |
| 0x400B_6000 | 0x400B_7FFF | GPIOD | |
| 0x400B_8000 | 0x400C_9FFF | Reserved | |
| 0x400C_A000 | 0x400C_AFFF | DIV | |
| 0x400C_B000 | 0x400D_FFFF | Reserved | |
| 0x400E_0000 | 0x400E_1FFF | QSPI | |
| 0x400E_2000 | 0x400F_FFFF | Reserved | |

Clock Structure

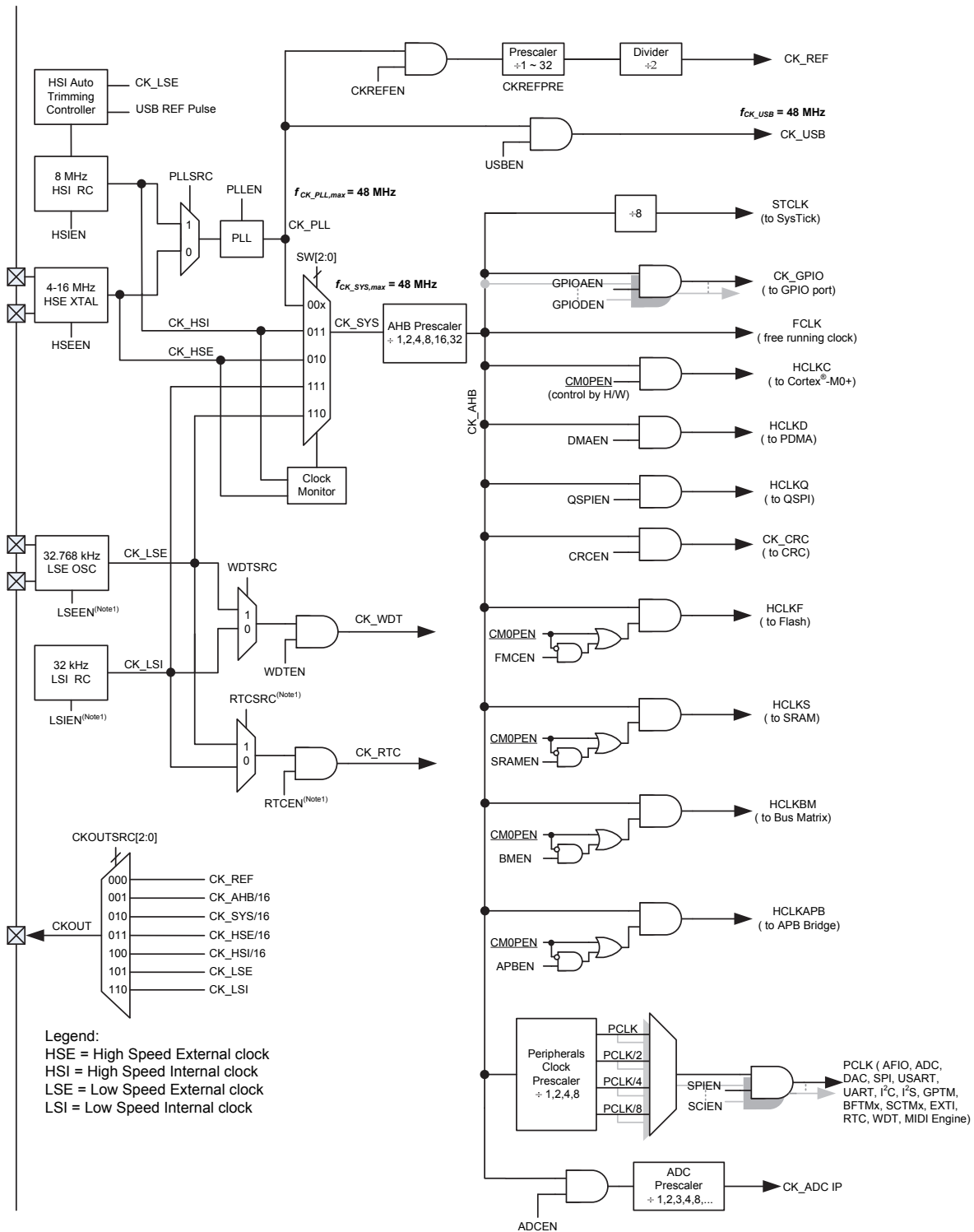

Figure 3. Clock Structure

5 SPI Flash Data Memory

The SPI Flash Data Memory is the location where the user's music data is stored. By using the Holtek Audio Workshop tool, these devices offer users the flexibility to conveniently change and develop their applications while also offering a means of field programming.

The Flash data memory supports the single bit and four bits serial input and output commands via standard Serial Peripheral Interface (SPI) pins: Serial Clock, Chip Select, Serial DQ0 (DI) and DQ1(DO), DQ2 and DQ3.

The internal Flash Data Memory within the devices has a capacity of 32 / 64 / 128 Mbits respectively and can be programmed 1 to 256 bytes each time, using the Page Program instruction.

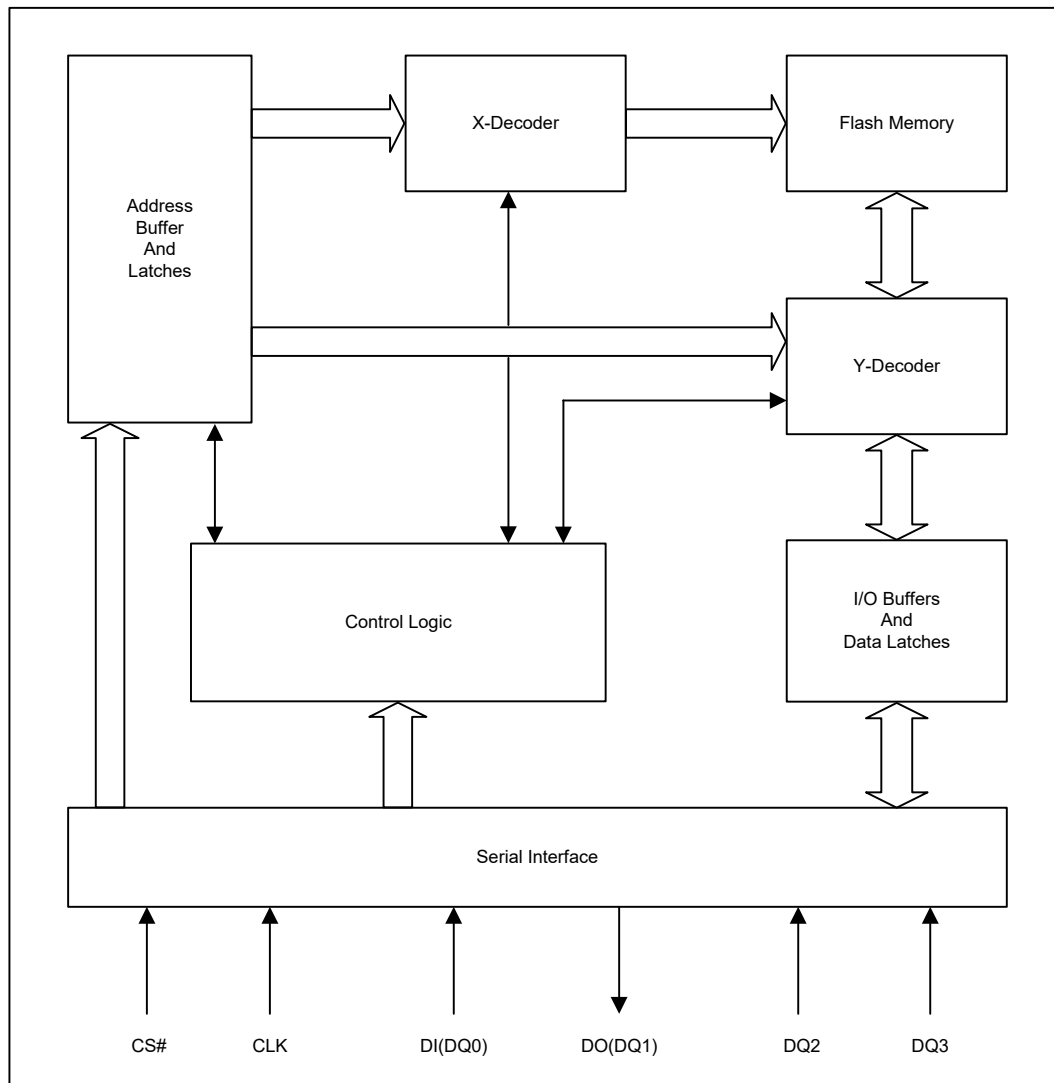

Standard SPI Modes

The Flash data memory is accessed through an SPI compatible bus consisting of four signals: Serial Clock (CLK), Chip Select (CS#), Serial Data Input (DI) and Serial Data Output (DO). Both SPI bus operation Modes 0 (0, 0) and 3 (1, 1) are supported. The primary difference between Mode 0 and Mode 3, as shown in the following figure, concerns the normal state of the CLK signal when the SPI bus master is in standby state and data is not being transferred to the Serial Flash. For Mode 0 the CLK signal is normally low. For Mode 3 the CLK signal is normally high. In either case data input on the DI pin is sampled on the rising edge of CLK. Data output on the DO pin is clocked out on the falling edge of CLK.

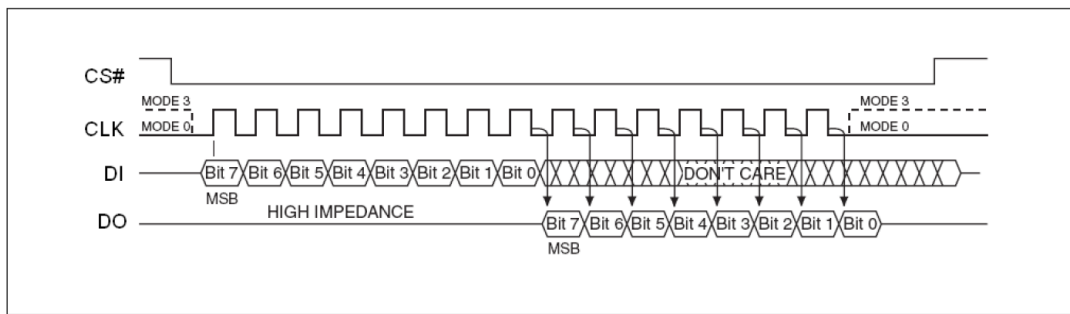

Quad I/O SPI Modes

The Flash Memory supports Quad input/output operation when using the Quad I/O Fast Read (EBh) instruction. This instruction allows data to be transferred to or from the Serial Flash memory at four to six times the rate possible with the standard SPI. When using Quad SPI instruction the DI and DO pins become bidirectional I/O pins DQ0 and DQ1, and DQ2 and DQ3 are also used.

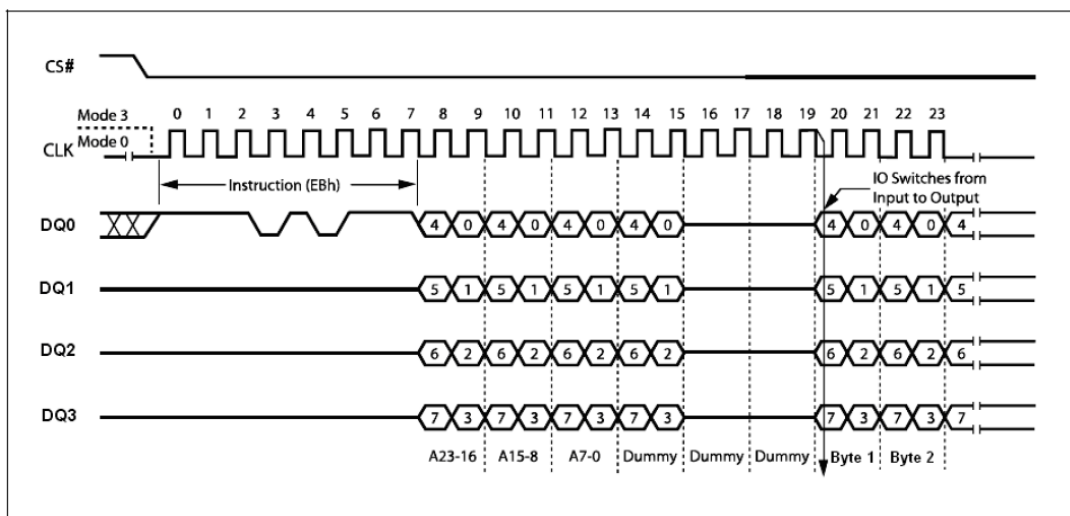

Read Data Bytes at Higher Speed (FAST_READ) (0Bh)

The Flash data Memory is first selected by driving Chip Select (CS#) to Low. The instruction code for the Read Data Bytes at Higher Speed (FAST_READ) instruction is followed by a 3-byte address (A23-A0) and a dummy byte, each bit being latched-in during the rising edge of Serial Clock (CLK). Then the memory contents, at that address, is shifted out on Serial Data Output (DO), each bit being shifted out at the falling edge of Serial Clock (CLK).

The instruction sequence is shown in following figure. The first byte to be addressed can be at any location. The address is automatically incremented to the next higher address after each byte of data is shifted out. The whole memory can, therefore, be read with a single Read Data Bytes at Higher Speed (FAST_READ) instruction. When the highest address is reached, the address counter rolls over to 000000h, allowing the read sequence to be continued indefinitely.

The Read Data Bytes at Higher Speed (FAST_READ) instruction is terminated by driving Chip Select (CS#) to High. Chip Select (CS#) can be driven High at any time during data output. Any Read Data Bytes at Higher Speed (FAST_READ) instruction, while an Erase, Program or Write cycle is in progress, is rejected without having any effects on the cycle that is in progress.

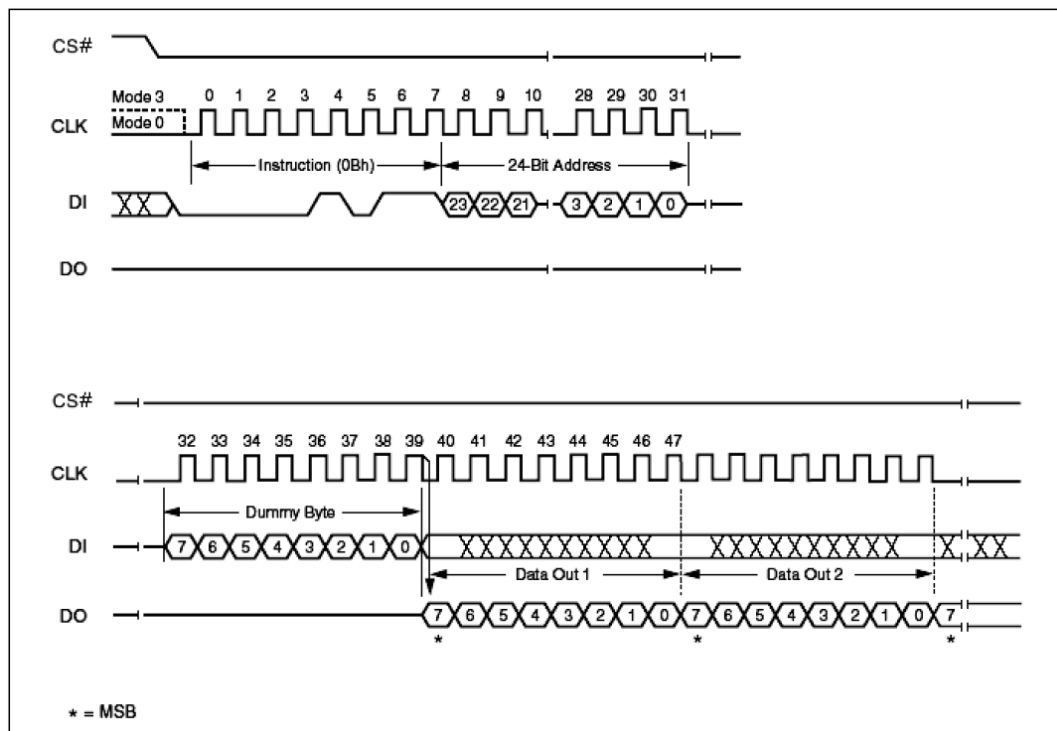

Quad Input / Output FAST_READ (EBh)

For the Quad Input/Output FAST_READ (EBh) instruction, the address and data bits are input and output through four pins, DQ0, DQ1, DQ2 and DQ3 and six dummy clocks are required prior to the data output. The Quad I/O dramatically reduces instruction overhead allowing faster random access for code execution (XIP) directly from the Quad SPI.

The Quad Input/Output FAST_READ (EBh) instruction enables quad throughput of Serial Flash in read mode. The address is latched on the rising edge of CLK, and data of every four bits (interleave on 4 I/O pins) is shifted out on the falling edge of CLK. The first address can be any location. The address is automatically increased to the next higher address after each byte data is shifted out, so the whole memory can be read out with a single Quad Input/Output FAST_READ instruction. The address counter rolls over to 000000h when the highest address has been reached. Once writing Quad Input/Output FAST_READ instruction, the following address/dummy/data out will be performed as 4-bit instead of previous 1-bit.

The sequence of issuing Quad Input/Output FAST_READ (EBh) instruction is: CS# goes low ⇒ send Quad Input/Output FAST_READ (EBh) instruction ⇒ 24-bit address interleave on DQ3, DQ2, DQ1 and DQ0 ⇒ 6 dummy clocks ⇒ data out interleave on DQ3, DQ2, DQ1 and DQ0 ⇒ drive CS# to High at any time during data out to end Quad Input/Output FAST_READ (EBh) operation, as shown in the following figure.

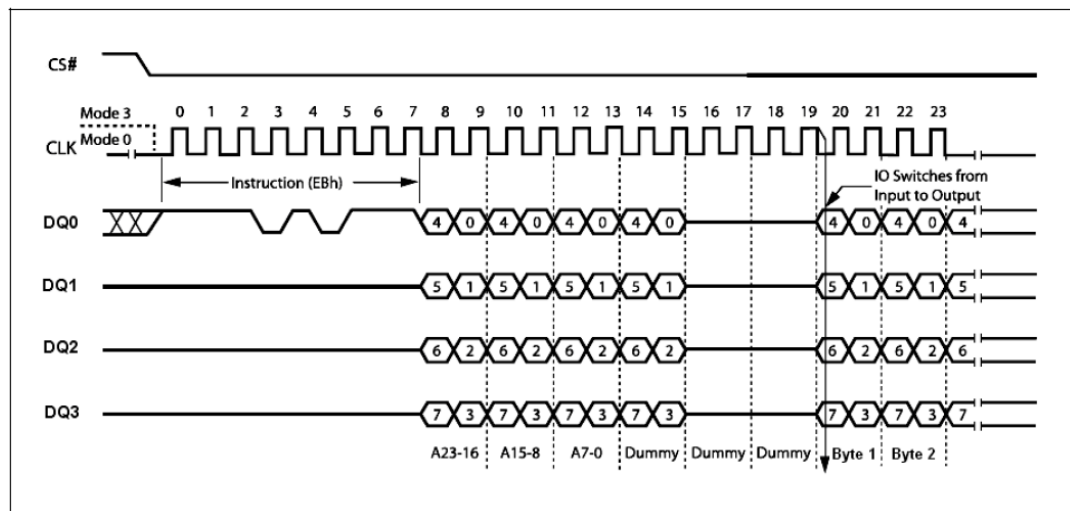

6 Pin Assignment

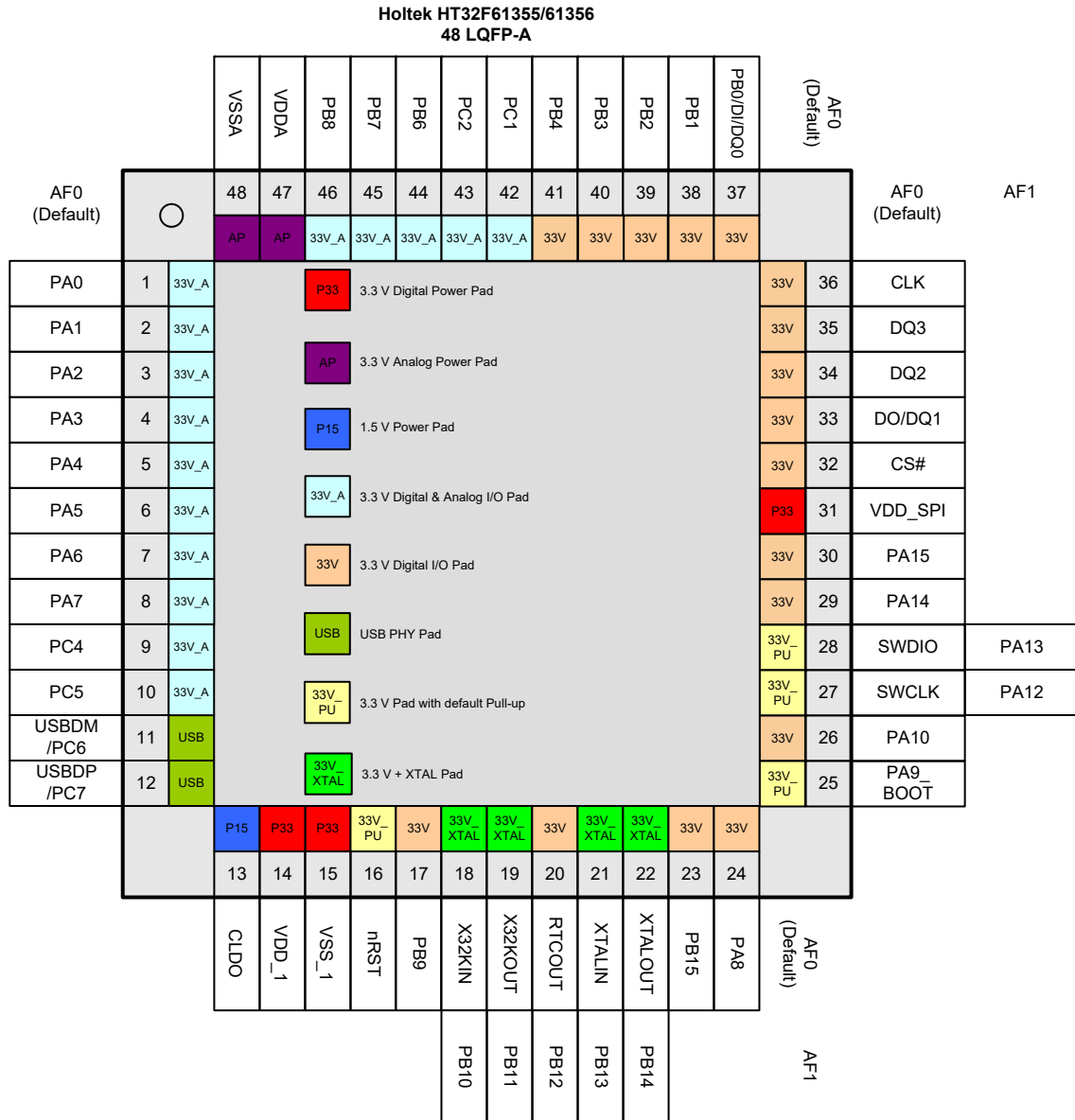

Figure 4. HT32F61355/61356 48-pin LQFP Pin Assignment

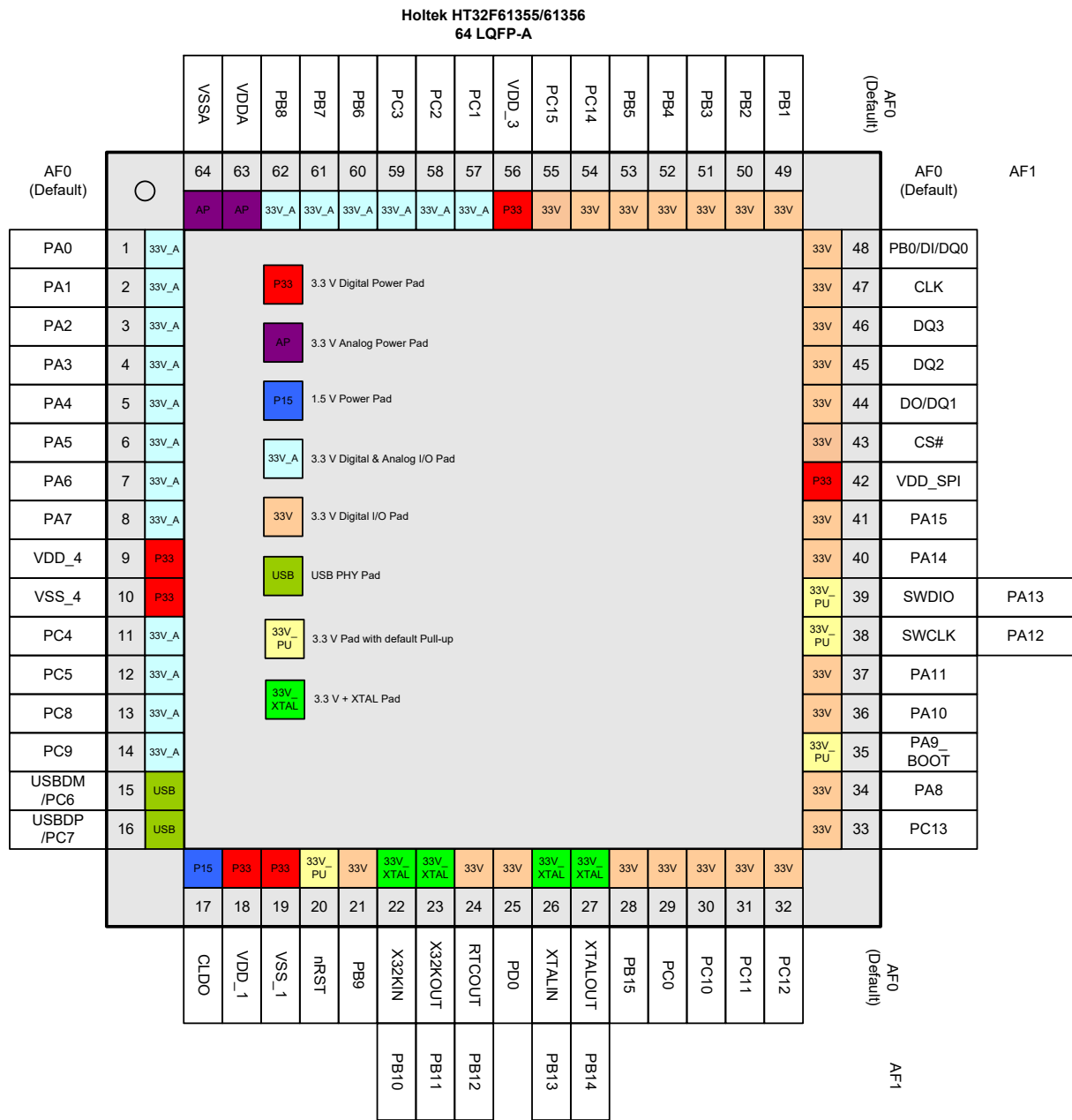

Figure 5. HT32F61355/61356 64-pin LQFP Pin Assignment

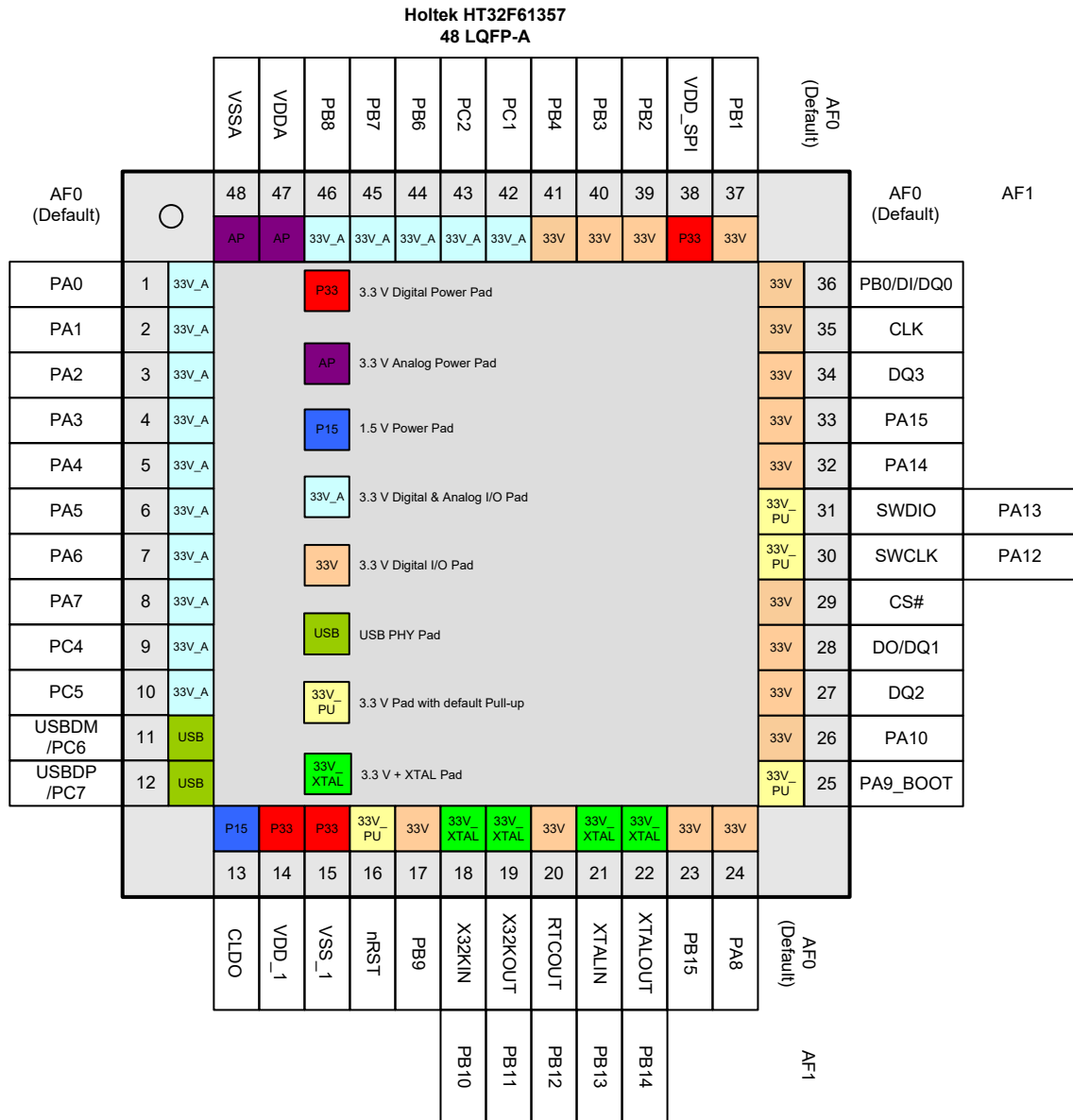
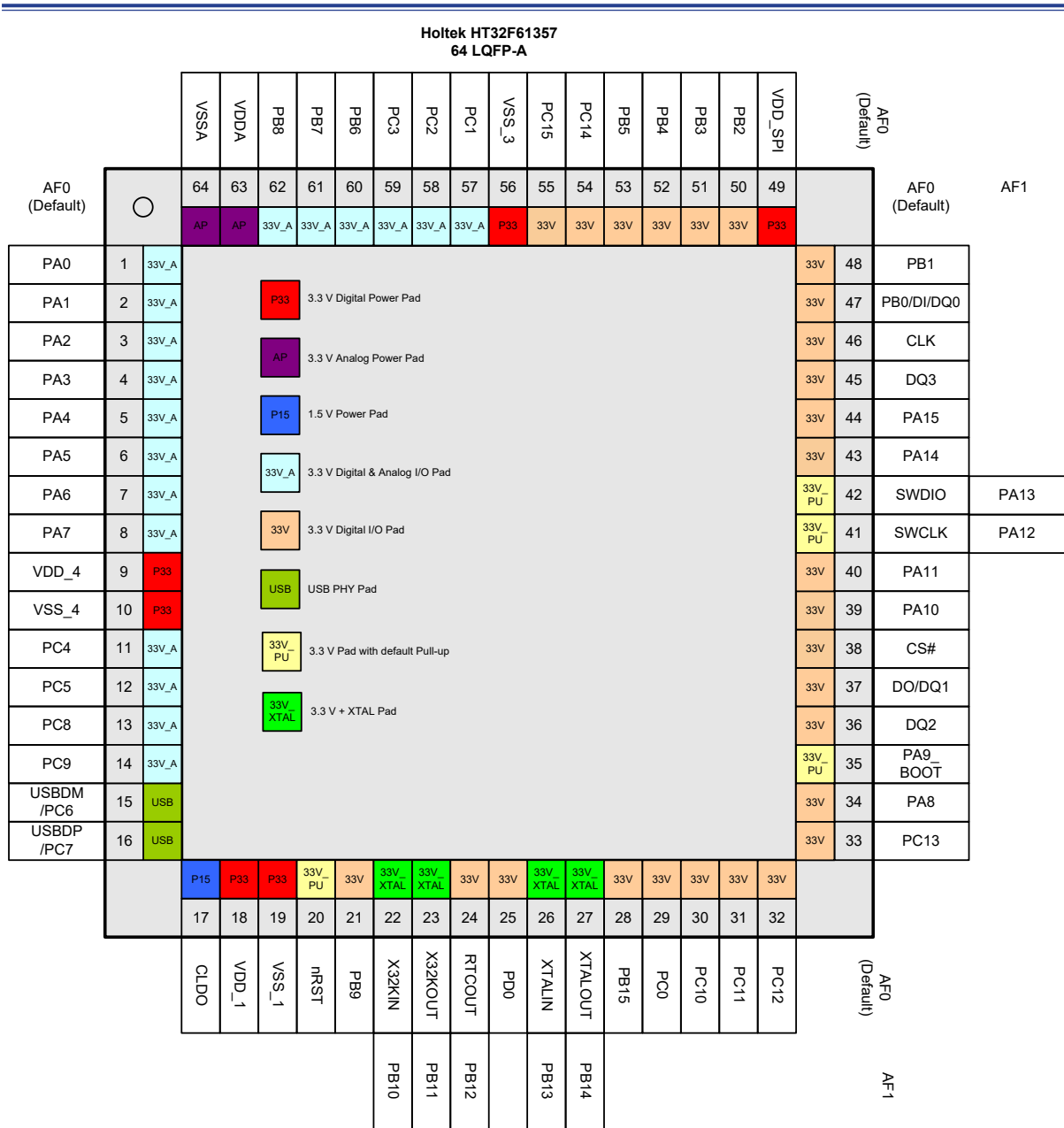

Figure 6. HT32F61357 48-pin LQFP Pin Assignment



6 Pin Assignment

Figure 7. HT32F61357 64-pin LQFP Pin Assignment

Table 3. HT32F61355/HT32F61356 48/64-pin LQFP Package

| Package | | Alternate Function Number | | | | | | | | | | | | | | | |
|---------|---------|---------------------------|-------------|----------------|------------|-------------|-----------------|-------------------|-------------------------|------------|------------|--------------------------|-------------|-------------|--------------|-------------|----------------------|
| 64 LQFP | 48 LQFP | AF0 System Default | AF1 GPIO | AF2 ADC/DAC | AF3 N/A | AF4 GPTM | AF5 SPI/QSPI | AF6 USART/UART | AF7 I ² C | AF8 N/A | AF9 N/A | AF10 I ² S | AF11 N/A | AF12 N/A | AF13 SCTM | AF14 N/A | AF15 System Other |
| 1 | 1 | PA0 | | ADC_IN4 | | | QSPI_SCK | USR_RTS | | | | I2S_WS | | | | | |
| 2 | 2 | PA1 | | ADC_IN5 | | | QSPI_SIO0 | USR_CTS | | | | I2S_BCLK | | | | | |
| 3 | 3 | PA2 | | ADC_IN6 | | | QSPI_SIO1 | USR_TX | | | | I2S_SDO | | | | | |
| 4 | 4 | PA3 | | ADC_IN7 | | | QSPI_SEL | USR_RX | | | | I2S_SDI | | | | | |
| 5 | 5 | PA4 | | ADC_IN8 | | GT_CH0 | SPI_SCK | | I2C_SCL | | | | | | | | |
| 6 | 6 | PA5 | | ADC_IN9 | | GT_CH1 | SPI_MOSI | | I2C_SDA | | | | | | | | |
| 7 | 7 | PA6 | | ADC_IN10 | | GT_CH2 | SPI_MISO | USR_RTS | | | | | | | | | |
| 8 | 8 | PA7 | | ADC_IN11 | | GT_CH3 | SPI_SEL | USR_CTS | | | | I2S_MCLK | | | | | |
| 9 | — | VDD_4 | | | | | | | | | | | | | | | |
| 10 | — | VSS_4 | | | | | | | | | | | | | | | |
| 11 | 9 | PC4 | | ADC_IN12 | | GT_CH0 | QSPI_SIO2 | UR_TX | | | | | | | SCTM0 | | |
| 12 | 10 | PC5 | | ADC_IN13 | | GT_CH1 | QSPI_SIO3 | UR_RX | | | | | | | SCTM1 | | |
| 13 | — | PC8 | | ADC_IN14 | | GT_CH2 | | | | | | | | | | | |
| 14 | — | PC9 | | ADC_IN15 | | GT_CH3 | | | | | | | | | | | |
| 15 | 11 | PC6 | | | | | | USR_TX | I2C_SCL | | | | | | | | |
| 15 | 11 | USBDM | | | | | | | | | | | | | | | |
| 16 | 12 | USBDP | | | | | | | | | | | | | | | |
| 16 | 12 | PC7 | | | | | | USR_RX | I2C_SDA | | | | | | | | |
| 17 | 13 | CLDO | | | | | | | | | | | | | | | |
| 18 | 14 | VDD_1 | | | | | | | | | | | | | | | |
| 19 | 15 | VSS_1 | | | | | | | | | | | | | | | |
| 20 | 16 | nRST | | | | | | | | | | | | | | | |
| 21 | 17 | PB9 | | | | | QSPI_SIO2 | | | | | | | | | | |
| 22 | 18 | X32KIN | PB10 | | | | | | | | | | | | SCTM2 | | |
| 23 | 19 | X32KOUT | PB11 | | | | | | | | | | | | SCTM3 | | |
| 24 | 20 | RTCOUT | PB12 | | | | | | | | | | | | SCTM0 | | WAKEUP |
| 25 | — | PD0 | | | | | QSPI_SIO3 | | I2C_SDA | | | I2S_SDI | | | | | |
| 26 | 21 | XTALIN | PB13 | | | | | | | | | | | | | | |
| 27 | 22 | XTALOUT | PB14 | | | | | | | | | | | | | | |
| 28 | 23 | PB15 | | | | | SPI_SEL | | | | | I2S_MCLK | | | | | |
| 29 | — | PC0 | | | | | SPI_SCK | | | | | | | | SCTM3 | | |
| 30 | — | PC10 | | | | | QSPI_SEL | | | | | I2S_WS | | | | | |
| 31 | — | PC11 | | | | | QSPI_SCK | | | | | I2S_BCLK | | | | | |
| 32 | — | PC12 | | | | | QSPI_SIO0 | | I2C_SCL | | | I2S_SDO | | | | | |
| 33 | — | PC13 | | | | | QSPI_SIO1 | | I2C_SDA | | | I2S_SDI | | | | | |
| 34 | 24 | PA8 | | | | | QSPI_SIO2 | USR_TX | | | | I2S_MCLK | | | SCTM2 | | |
| 35 | 25 | PA9_BOOT | | | | | SPI_MOSI | | | | | I2S_WS | | | SCTM3 | | CKOUT |
| 36 | 26 | PA10 | | | | | QSPI_SIO3 | USR_RX | | | | | | | | | |
| 37 | — | PA11 | | | | | SPI_MISO | | | | | I2S_MCLK | | | SCTM0 | | |
| 38 | 27 | SWCLK | PA12 | | | | | | | | | | | | | | |
| 39 | 28 | SWDIO | PA13 | | | | | | | | | | | | | | |
| 40 | 29 | PA14 | | | | | QSPI_SEL | | | | | | | | | | |
| 41 | 30 | PA15 | | | | | QSPI_SCK | | | | | | | | SCTM1 | | |
| 42 | 31 | VDD_SPI | | | | | | | | | | | | | | | |
| 43 | 32 | CS# | | | | | | | | | | | | | | | |
| 44 | 33 | DO/DQ1 | | | | | | | | | | | | | | | |
| 45 | 34 | DQ2 | | | | | | | | | | | | | | | |
| 46 | 35 | DQ3 | | | | | | | | | | | | | | | |
| 47 | 36 | CLK | | | | | | | | | | | | | | | |
| 48 | 37 | PB0 | | | | | QSPI_SIO0 | USR_TX | I2C_SCL | | | | | | | | |
| 48 | 37 | DI/DQ0 | | | | | | | | | | | | | | | |
| 49 | 38 | PB1 | | | | | QSPI_SIO1 | USR_RX | I2C_SDA | | | | | | SCTM2 | | |
| 50 | 39 | PB2 | | | | | SPI_SEL | UR_TX | | | | | | | | | CKIN (Auto-trim) |
| 51 | 40 | PB3 | | | | | SPI_SCK | UR_RX | | | | | | | SCTM1 | | |
| 52 | 41 | PB4 | | | | | SPI_MOSI | | | | | | | | SCTM0 | | |

| Package | | Alternate Function Number | | | | | | | | | | | | | | | | |
|---------|---------|---------------------------|------|---------|-----|------|-----------|------------|----------------------|-----|-----|-----------------------|------|------|------|------|--------------|------|
| 64 LQFP | 48 LQFP | System Default | AF0 | AF1 | AF2 | AF3 | AF4 | AF5 | AF6 | AF7 | AF8 | AF9 | AF10 | AF11 | AF12 | AF13 | AF14 | AF15 |
| | | | GPIO | ADC/DAC | N/A | GPTM | SPI/QSPI | USART/UART | I ² C | N/A | N/A | I ² S | N/A | N/A | SCTM | N/A | System Other | |
| 53 | — | PB5 | | | | | SPI_MISO | | | | | | | | | | | |
| 54 | — | PC14 | | | | | | | I ² C_SCL | | | | | | | | | |
| 55 | — | PC15 | | | | | | | I ² C_SDA | | | | | | | | | |
| 56 | — | VDD_3 | | | | | | | | | | | | | | | | |
| 57 | 42 | PC1 | | DAC_RCH | | | QSPI_SEL | | | | | I ² S_MCLK | | | | | | |
| 58 | 43 | PC2 | | DAC_LCH | | | QSPI_SCK | | | | | | | | | | | |
| 59 | — | PC3 | | ADC_IN0 | | | QSPI_SIO0 | | | | | | | | | | | |
| 60 | 44 | PB6 | | ADC_IN1 | | | QSPI_SIO1 | UR_TX | | | | I ² S_BCLK | | | | | | |
| 61 | 45 | PB7 | | ADC_IN2 | | | QSPI_SIO2 | | | | | I ² S_SDO | | | | | | |
| 62 | 46 | PB8 | | ADC_IN3 | | | QSPI_SIO3 | UR_RX | | | | I ² S_SDI | | | | | | |
| 63 | 47 | VDDA | | | | | | | | | | | | | | | | |
| 64 | 48 | VSSA | | | | | | | | | | | | | | | | |

Table 4. HT32F61357 48/64-pin LQFP Package

| Package | | Alternate Function Number | | | | | | | | | | | | | | | | |
|---------|---------|---------------------------|------|----------|-----|--------|-----------|------------|----------------------|-----|-----|-----------------------|------|------|-------|------|--------------|--------|
| 64 LQFP | 48 LQFP | System Default | AF0 | AF1 | AF2 | AF3 | AF4 | AF5 | AF6 | AF7 | AF8 | AF9 | AF10 | AF11 | AF12 | AF13 | AF14 | AF15 |
| | | | GPIO | ADC/DAC | N/A | GPTM | SPI/QSPI | USART/UART | I ² C | N/A | N/A | I ² S | N/A | N/A | SCTM | N/A | System Other | |
| 1 | 1 | PA0 | | ADC_IN4 | | | QSPI_SCK | USR_RTS | | | | I ² S_WS | | | | | | |
| 2 | 2 | PA1 | | ADC_IN5 | | | QSPI_SIO0 | USR_CTS | | | | I ² S_BCLK | | | | | | |
| 3 | 3 | PA2 | | ADC_IN6 | | | QSPI_SIO1 | USR_TX | | | | I ² S_SDO | | | | | | |
| 4 | 4 | PA3 | | ADC_IN7 | | | QSPI_SEL | USR_RX | | | | I ² S_SDI | | | | | | |
| 5 | 5 | PA4 | | ADC_IN8 | | GT_CH0 | SPI_SCK | | I ² C_SCL | | | | | | | | | |
| 6 | 6 | PA5 | | ADC_IN9 | | GT_CH1 | SPI_MOSI | | I ² C_SDA | | | | | | | | | |
| 7 | 7 | PA6 | | ADC_IN10 | | GT_CH2 | SPI_MISO | USR_RTS | | | | | | | | | | |
| 8 | 8 | PA7 | | ADC_IN11 | | GT_CH3 | SPI_SEL | USR_CTS | | | | I ² S_MCLK | | | | | | |
| 9 | — | VDD_4 | | | | | | | | | | | | | | | | |
| 10 | — | VSS_4 | | | | | | | | | | | | | | | | |
| 11 | 9 | PC4 | | ADC_IN12 | | GT_CH0 | QSPI_SIO2 | UR_TX | | | | | | | SCTM0 | | | |
| 12 | 10 | PC5 | | ADC_IN13 | | GT_CH1 | QSPI_SIO3 | UR_RX | | | | | | | SCTM1 | | | |
| 13 | — | PC8 | | ADC_IN14 | | GT_CH2 | | | | | | | | | | | | |
| 14 | — | PC9 | | ADC_IN15 | | GT_CH3 | | | | | | | | | | | | |
| 15 | 11 | PC6 | | | | | | USR_TX | I ² C_SCL | | | | | | | | | |
| 15 | 11 | USBDM | | | | | | | | | | | | | | | | |
| 16 | 12 | USBDP | | | | | | | | | | | | | | | | |
| 16 | 12 | PC7 | | | | | | USR_RX | I ² C_SDA | | | | | | | | | |
| 17 | 13 | CLDO | | | | | | | | | | | | | | | | |
| 18 | 14 | VDD_1 | | | | | | | | | | | | | | | | |
| 19 | 15 | VSS_1 | | | | | | | | | | | | | | | | |
| 20 | 16 | nRST | | | | | | | | | | | | | | | | |
| 21 | 17 | PB9 | | | | | QSPI_SIO2 | | | | | | | | | | | |
| 22 | 18 | X32KIN | PB10 | | | | | | | | | | | | SCTM2 | | | |
| 23 | 19 | X32KOUT | PB11 | | | | | | | | | | | | SCTM3 | | | |
| 24 | 20 | RTCOUT | PB12 | | | | | | | | | | | | SCTM0 | | | WAKEUP |
| 25 | — | PD0 | | | | | QSPI_SIO3 | | I ² C_SDA | | | I ² S_SDI | | | | | | |
| 26 | 21 | XTALIN | PB13 | | | | | | | | | | | | | | | |
| 27 | 22 | XTALOUT | PB14 | | | | | | | | | | | | | | | |
| 28 | 23 | PB15 | | | | | SPI_SEL | | | | | I ² S_MCLK | | | | | | |
| 29 | — | PC0 | | | | | SPI_SCK | | | | | | | | SCTM3 | | | |
| 30 | — | PC10 | | | | | QSPI_SEL | | | | | I ² S_WS | | | | | | |
| 31 | — | PC11 | | | | | QSPI_SCK | | | | | I ² S_BCLK | | | | | | |
| 32 | — | PC12 | | | | | QSPI_SIO0 | | I ² C_SCL | | | I ² S_SDO | | | | | | |
| 33 | — | PC13 | | | | | QSPI_SIO1 | | I ² C_SDA | | | I ² S_SDI | | | | | | |
| 34 | 24 | PA8 | | | | | QSPI_SIO2 | USR_TX | | | | I ² S_MCLK | | | SCTM2 | | | |
| 35 | 25 | PA9_BOOT | | | | | SPI_MOSI | | | | | I ² S_WS | | | SCTM3 | | | CKOUT |
| 36 | 27 | DQ2 | | | | | | | | | | | | | | | | |
| 37 | 28 | DO/DQ1 | | | | | | | | | | | | | | | | |

| Package | | Alternate Function Number | | | | | | | | | | | | | | | |
|---------|---------|---------------------------|------|----------|-----|------|-----------|-------------|------------------|-----|-----|------------------|------|------|-------|------|------------------|
| 64 LQFP | 48 LQFP | AF0 | AF1 | AF2 | AF3 | AF4 | AF5 | AF6 | AF7 | AF8 | AF9 | AF10 | AF11 | AF12 | AF13 | AF14 | AF15 |
| | | System Default | GPIO | ADC /DAC | N/A | GPTM | SPI/QSPI | USART /UART | I ² C | N/A | N/A | I ² S | N/A | N/A | SCTM | N/A | System Other |
| 38 | 29 | CS# | | | | | | | | | | | | | | | |
| 39 | 26 | PA10 | | | | | QSPI_SIO3 | USR_RX | | | | | | | | | |
| 40 | — | PA11 | | | | | SPI_MISO | | | | | I2S_MCLK | | | SCTM0 | | |
| 41 | 30 | SWCLK | PA12 | | | | | | | | | | | | | | |
| 42 | 31 | SWDIO | PA13 | | | | | | | | | | | | | | |
| 43 | 32 | PA14 | | | | | QSPI_SEL | | | | | | | | | | |
| 44 | 33 | PA15 | | | | | QSPI_SCK | | | | | | | | SCTM1 | | |
| 45 | 34 | DQ3 | | | | | | | | | | | | | | | |
| 46 | 35 | CLK | | | | | | | | | | | | | | | |
| 47 | 36 | PB0 | | | | | QSPI_SIO0 | USR_TX | I2C_SCL | | | | | | | | |
| 47 | 36 | DI/DQ0 | | | | | | | | | | | | | | | |
| 48 | 37 | PB1 | | | | | QSPI_SIO1 | USR_RX | I2C_SDA | | | | | | SCTM2 | | |
| 49 | 38 | VDD_SPI | | | | | | | | | | | | | | | |
| 50 | 39 | PB2 | | | | | SPI_SEL | UR_TX | | | | | | | | | CKIN (Auto-trim) |
| 51 | 40 | PB3 | | | | | SPI_SCK | UR_RX | | | | | | | SCTM1 | | |
| 52 | 41 | PB4 | | | | | SPI_MOSI | | | | | | | | SCTM0 | | |
| 53 | — | PB5 | | | | | SPI_MISO | | | | | | | | | | |
| 54 | — | PC14 | | | | | | | I2C_SCL | | | | | | | | |
| 55 | — | PC15 | | | | | | | I2C_SDA | | | | | | | | |
| 56 | — | VSS_3 | | | | | | | | | | | | | | | |
| 57 | 42 | PC1 | | DAC_RCH | | | QSPI_SEL | | | | | I2S_MCLK | | | | | |
| 58 | 43 | PC2 | | DAC_LCH | | | QSPI_SCK | | | | | | | | | | |
| 59 | — | PC3 | | ADC_IN0 | | | QSPI_SIO0 | | | | | | | | | | |
| 60 | 44 | PB6 | | ADC_IN1 | | | QSPI_SIO1 | UR_TX | | | | I2S_BCLK | | | | | |
| 61 | 45 | PB7 | | ADC_IN2 | | | QSPI_SIO2 | | | | | I2S_SDO | | | | | |
| 62 | 46 | PB8 | | ADC_IN3 | | | QSPI_SIO3 | UR_RX | | | | I2S_SDI | | | | | |
| 63 | 47 | VDDA | | | | | | | | | | | | | | | |
| 64 | 48 | VSSA | | | | | | | | | | | | | | | |

Table 5. HT32F61355/HT32F61356 Pin Description

| Pin Number | | Pin Name | Type ⁽¹⁾ | I/O Structure ⁽²⁾ | Output Driving | Description |
|------------|--------|----------|---------------------|------------------------------|----------------|--|
| 64LQFP | 48LQFP | | | | | Default Function (AF0) |
| 1 | 1 | PA0 | AI/O | 33V | 4/8/12/16 mA | PA0 |
| 2 | 2 | PA1 | AI/O | 33V | 4/8/12/16 mA | PA1 |
| 3 | 3 | PA2 | AI/O | 33V | 4/8/12/16 mA | PA2, this pin provides a UART_TX function in the Boot loader mode. |
| 4 | 4 | PA3 | AI/O | 33V | 4/8/12/16 mA | PA3, this pin provides a UART_RX function in the Boot loader mode. |
| 5 | 5 | PA4 | AI/O | 33V | 4/8/12/16 mA | PA4 |
| 6 | 6 | PA5 | AI/O | 33V | 4/8/12/16 mA | PA5 |
| 7 | 7 | PA6 | AI/O | 33V | 4/8/12/16 mA | PA6 |
| 8 | 8 | PA7 | AI/O | 33V | 4/8/12/16 mA | PA7 |
| 9 | — | VDD_4 | P | — | — | Voltage for digital I/O |
| 10 | — | VSS_4 | P | — | — | Ground reference for digital I/O |
| 11 | 9 | PC4 | AI/O | 33V | 4/8/12/16 mA | PC4 |
| 12 | 10 | PC5 | AI/O | 33V | 4/8/12/16 mA | PC5 |
| 13 | — | PC8 | AI/O | 33V | 4/8/12/16 mA | PC8 |
| 14 | — | PC9 | AI/O | 33V | 4/8/12/16 mA | PC9 |
| 15 | 11 | PC6 | I/O | 33V | 4/8/12/16 mA | PC6 |
| 15 | 11 | USBDM | AI/O | — | — | USB Differential data bus conforming to the Universal Serial Bus standard. |
| 16 | 12 | USBDP | AI/O | — | — | USB Differential data bus conforming to the Universal Serial Bus standard. |
| 16 | 12 | PC7 | I/O | 33V | 4/8/12/16 mA | PC7 |
| 17 | 13 | CLDO | P | — | — | Core power LDO 1.5 V output. It is recommended to connect a 1 μF capacitor as close as possible between this pin and VSS_1. |
| 18 | 14 | VDD_1 | P | — | — | Voltage for digital I/O |
| 19 | 15 | VSS_1 | P | — | — | Ground reference for digital I/O |
| 20 | 16 | nRST | I | 33V_PU | — | External reset pin and external wakeup pin in the Power-Down mode |
| 21 | 17 | PB9 | I/O | 33V | 4/8/12/16 mA | PB9 |
| 22 | 18 | PB10 | AI/O | 33V | < 2 mA | X32KIN |
| 23 | 19 | PB11 | AI/O | 33V | < 2 mA | X32KOUT |
| 24 | 20 | PB12 | I/O | 33V | < 2 mA | RTCOUT |
| 25 | — | PD0 | I/O | 33V | 4/8/12/16 mA | PD0 |
| 26 | 21 | PB13 | AI/O | 33V | 4/8/12/16 mA | XTALIN |
| 27 | 22 | PB14 | AI/O | 33V | 4/8/12/16 mA | XTALOUT |
| 28 | 23 | PB15 | I/O | 33V | 4/8/12/16 mA | PB15 |
| 29 | — | PC0 | I/O | 33V | 4/8/12/16 mA | PC0 |
| 30 | — | PC10 | I/O | 33V | 4/8/12/16 mA | PC10 |
| 31 | — | PC11 | I/O | 33V | 4/8/12/16 mA | PC11 |
| 32 | — | PC12 | I/O | 33V | 4/8/12/16 mA | PC12 |
| 33 | — | PC13 | I/O | 33V | 4/8/12/16 mA | PC13 |
| 34 | 24 | PA8 | I/O | 33V | 4/8/12/16 mA | PA8 |
| 35 | 25 | PA9 | I/O | 33V_PU | 4/8/12/16 mA | PA9_BOOT |
| 36 | 26 | PA10 | I/O | 33V | 4/8/12/16 mA | PA10 |
| 37 | — | PA11 | I/O | 33V | 4/8/12/16 mA | PA11 |

| Pin Number | | Pin Name | Type ⁽¹⁾ | I/O Structure ⁽²⁾ | Output Driving | Description |
|------------|--------|----------|---------------------|------------------------------|----------------|---|
| 64LQFP | 48LQFP | | | | | Default Function (AF0) |
| 38 | 27 | PA12 | I/O | 33V_PU | 4/8/12/16 mA | SWCLK |
| 39 | 28 | PA13 | I/O | 33V_PU | 4/8/12/16 mA | SWDIO |
| 40 | 29 | PA14 | I/O | 33V | 4/8/12/16 mA | PA14 |
| 41 | 30 | PA15 | I/O | 33V | 4/8/12/16 mA | PA15 |
| 42 | 31 | VDD_SPI | P | — | — | SPI Flash Data Memory Power |
| 43 | 32 | CS# | I/O | 33V | — | SPI Flash Data Memory Chip Select |
| 44 | 33 | DO/DQ1 | I/O | 33V | — | SPI Flash Data Memory Serial Data Output or Data Input / Output 1 |
| 45 | 34 | DQ2 | I/O | 33V | — | SPI Flash Data Memory Serial Data Input / Output 2 |
| 46 | 35 | DQ3 | I/O | 33V | — | SPI Flash Data Memory Serial Data Input / Output 3 |
| 47 | 36 | CLK | I/O | 33V | — | SPI Flash Data Memory Serial Clock Input |
| 48 | 37 | PB0 | I/O | 33V | 4/8/12/16 mA | PB0 |
| 48 | 37 | DI/DQ0 | I/O | 33V | — | SPI Flash Data Memory Serial Data Input or Data Input / Output 0 |
| 49 | 38 | PB1 | I/O | 33V | 4/8/12/16 mA | PB1 |
| 50 | 39 | PB2 | I/O | 33V | 4/8/12/16 mA | PB2 |
| 51 | 40 | PB3 | I/O | 33V | 4/8/12/16 mA | PB3 |
| 52 | 41 | PB4 | I/O | 33V | 4/8/12/16 mA | PB4 |
| 53 | — | PB5 | I/O | 33V | 4/8/12/16 mA | PB5 |
| 54 | — | PC14 | I/O | 33V | 4/8/12/16 mA | PC14 |
| 55 | — | PC15 | I/O | 33V | 4/8/12/16 mA | PC15 |
| 56 | — | VDD_3 | P | — | — | Voltage for digital I/O |
| 57 | 42 | PC1 | AI/O | 33V | 4/8/12/16 mA | PC1 |
| 58 | 43 | PC2 | AI/O | 33V | 4/8/12/16 mA | PC2 |
| 59 | — | PC3 | AI/O | 33V | 4/8/12/16 mA | PC3 |
| 60 | 44 | PB6 | AI/O | 33V | 4/8/12/16 mA | PB6 |
| 61 | 45 | PB7 | AI/O | 33V | 4/8/12/16 mA | PB7 |
| 62 | 46 | PB8 | AI/O | 33V | 4/8/12/16 mA | PB8 |
| 63 | 47 | VDDA | P | — | — | Analog voltage for ADC and DAC |
| 64 | 48 | VSSA | P | — | — | Ground reference for the ADC and DAC |

Notes: 1. I = input, O = output, A = Analog port, P = power supply, PU = pull-up.

2. 33V = 3.3 V tolerant.

3. The GPIOs are in an AF0 state after a V_{DD15} power on reset (POR) except for the RTCOUT pin.

4. In the Boot loader mode, the UART and USB interfaces are available for communication.

Table 6. HT32F61357 Pin Description

| Pin Number | | Pin Name | Type ⁽¹⁾ | I/O Structure ⁽²⁾ | Output Driving | Description |
|------------|--------|----------|---------------------|------------------------------|----------------|--|
| 64LQFP | 48LQFP | | | | | Default Function (AF0) |
| 1 | 1 | PA0 | AI/O | 33V | 4/8/12/16 mA | PA0 |
| 2 | 2 | PA1 | AI/O | 33V | 4/8/12/16 mA | PA1 |
| 3 | 3 | PA2 | AI/O | 33V | 4/8/12/16 mA | PA2, this pin provides a UART_TX function in the Boot loader mode. |
| 4 | 4 | PA3 | AI/O | 33V | 4/8/12/16 mA | PA3, this pin provides a UART_RX function in the Boot loader mode. |
| 5 | 5 | PA4 | AI/O | 33V | 4/8/12/16 mA | PA4 |
| 6 | 6 | PA5 | AI/O | 33V | 4/8/12/16 mA | PA5 |
| 7 | 7 | PA6 | AI/O | 33V | 4/8/12/16 mA | PA6 |
| 8 | 8 | PA7 | AI/O | 33V | 4/8/12/16 mA | PA7 |
| 9 | — | VDD_4 | P | — | — | Voltage for digital I/O |
| 10 | — | VSS_4 | P | — | — | Ground reference for digital I/O |
| 11 | 9 | PC4 | AI/O | 33V | 4/8/12/16 mA | PC4 |
| 12 | 10 | PC5 | AI/O | 33V | 4/8/12/16 mA | PC5 |
| 13 | — | PC8 | AI/O | 33V | 4/8/12/16 mA | PC8 |
| 14 | — | PC9 | AI/O | 33V | 4/8/12/16 mA | PC9 |
| 15 | 11 | PC6 | I/O | 33V | 4/8/12/16 mA | PC6 |
| 15 | 11 | USBDM | AI/O | — | — | USB Differential data bus conforming to the Universal Serial Bus standard. |
| 16 | 12 | USBDP | AI/O | — | — | USB Differential data bus conforming to the Universal Serial Bus standard. |
| 16 | 12 | PC7 | I/O | 33V | 4/8/12/16 mA | PC7 |
| 17 | 13 | CLDO | P | — | — | Core power LDO 1.5 V output. It is recommended to connect a 1 μF capacitor as close as possible between this pin and VSS_1. |
| 18 | 14 | VDD_1 | P | — | — | Voltage for digital I/O |
| 19 | 15 | VSS_1 | P | — | — | Ground reference for digital I/O |
| 20 | 16 | nRST | I | 33V_PU | — | External reset pin and external wakeup pin in the Power-Down mode |
| 21 | 17 | PB9 | I/O | 33V | 4/8/12/16 mA | PB9 |
| 22 | 18 | PB10 | AI/O | 33V | < 2 mA | X32KIN |
| 23 | 19 | PB11 | AI/O | 33V | < 2 mA | X32KOUT |
| 24 | 20 | PB12 | I/O | 33V | < 2 mA | RTCOUT |
| 25 | — | PD0 | I/O | 33V | 4/8/12/16 mA | PD0 |
| 26 | 21 | PB13 | AI/O | 33V | 4/8/12/16 mA | XTALIN |
| 27 | 22 | PB14 | AI/O | 33V | 4/8/12/16 mA | XTALOUT |
| 28 | 23 | PB15 | I/O | 33V | 4/8/12/16 mA | PB15 |
| 29 | — | PC0 | I/O | 33V | 4/8/12/16 mA | PC0 |
| 30 | — | PC10 | I/O | 33V | 4/8/12/16 mA | PC10 |
| 31 | — | PC11 | I/O | 33V | 4/8/12/16 mA | PC11 |
| 32 | — | PC12 | I/O | 33V | 4/8/12/16 mA | PC12 |
| 33 | — | PC13 | I/O | 33V | 4/8/12/16 mA | PC13 |
| 34 | 24 | PA8 | I/O | 33V | 4/8/12/16 mA | PA8 |
| 35 | 25 | PA9 | I/O | 33V_PU | 4/8/12/16 mA | PA9_BOOT |
| 36 | 27 | DQ2 | I/O | 33V | — | SPI Flash Data Memory Serial Data Input / Output 2 |

| Pin Number | | Pin Name | Type ⁽¹⁾ | I/O Structure ⁽²⁾ | Output Driving | Description |
|------------|--------|----------|---------------------|------------------------------|----------------|---|
| 64LQFP | 48LQFP | | | | | Default Function (AF0) |
| 37 | 28 | DO/DQ1 | I/O | 33V | — | SPI Flash Data Memory Serial Data Output or Data Input / Output 1 |
| 38 | 29 | CS# | I/O | 33V | — | SPI Flash Data Memory Chip Select |
| 39 | 26 | PA10 | I/O | 33V | 4/8/12/16 mA | PA10 |
| 40 | — | PA11 | I/O | 33V | 4/8/12/16 mA | PA11 |
| 41 | 30 | PA12 | I/O | 33V_PU | 4/8/12/16 mA | SWCLK |
| 42 | 31 | PA13 | I/O | 33V_PU | 4/8/12/16 mA | SWDIO |
| 43 | 32 | PA14 | I/O | 33V | 4/8/12/16 mA | PA14 |
| 44 | 33 | PA15 | I/O | 33V | 4/8/12/16 mA | PA15 |
| 45 | 34 | DQ3 | I/O | 33V | — | SPI Flash Data Memory Serial Data Input / Output 3 |
| 46 | 35 | CLK | I/O | 33V | — | SPI Flash Data Memory Serial Clock Input |
| 47 | 36 | PB0 | I/O | 33V | 4/8/12/16 mA | PB0 |
| 47 | 36 | DI/DQ0 | I/O | 33V | — | SPI Flash Data Memory Serial Data Input or Data Input / Output 0 |
| 48 | 37 | PB1 | I/O | 33V | 4/8/12/16 mA | PB1 |
| 49 | 38 | VDD_SPI | P | — | — | SPI Flash Data Memory Power |
| 50 | 39 | PB2 | I/O | 33V | 4/8/12/16 mA | PB2 |
| 51 | 40 | PB3 | I/O | 33V | 4/8/12/16 mA | PB3 |
| 52 | 41 | PB4 | I/O | 33V | 4/8/12/16 mA | PB4 |
| 53 | — | PB5 | I/O | 33V | 4/8/12/16 mA | PB5 |
| 54 | — | PC14 | I/O | 33V | 4/8/12/16 mA | PC14 |
| 55 | — | PC15 | I/O | 33V | 4/8/12/16 mA | PC15 |
| 56 | — | VSS_3 | P | — | — | Ground reference for digital I/O |
| 57 | 42 | PC1 | AI/O | 33V | 4/8/12/16 mA | PC1 |
| 58 | 43 | PC2 | AI/O | 33V | 4/8/12/16 mA | PC2 |
| 59 | — | PC3 | AI/O | 33V | 4/8/12/16 mA | PC3 |
| 60 | 44 | PB6 | AI/O | 33V | 4/8/12/16 mA | PB6 |
| 61 | 45 | PB7 | AI/O | 33V | 4/8/12/16 mA | PB7 |
| 62 | 46 | PB8 | AI/O | 33V | 4/8/12/16 mA | PB8 |
| 63 | 47 | VDDA | P | — | — | Analog voltage for ADC and DAC |
| 64 | 48 | VSSA | P | — | — | Ground reference for the ADC and DAC |

Notes: 1. I = input, O = output, A = Analog port, P = power supply, PU = pull-up.

2. 33V = 3.3 V tolerant.

3. The GPIOs are in an AF0 state after a V_{DD15} power on reset (POR) except for the RTCOUT pin.

4. In the Boot loader mode, the UART and USB interfaces are available for communication.

7 Application Block

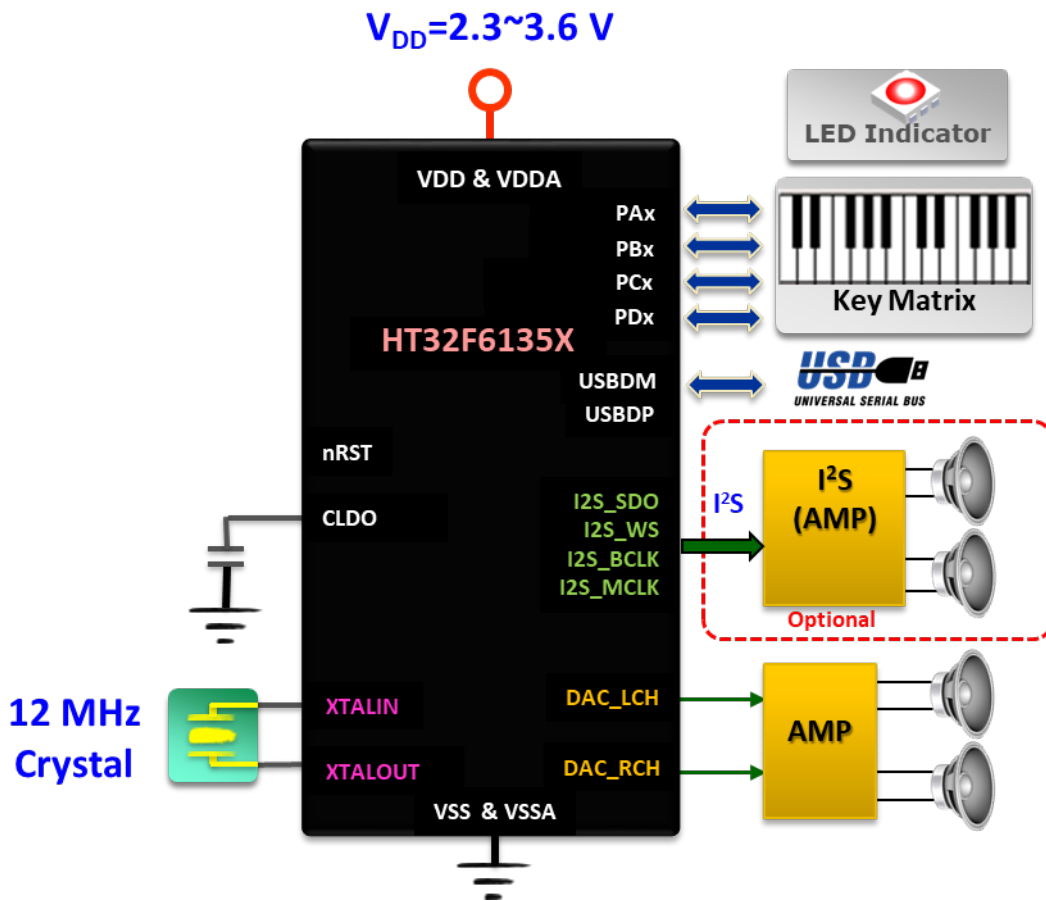

8 Application Circuits

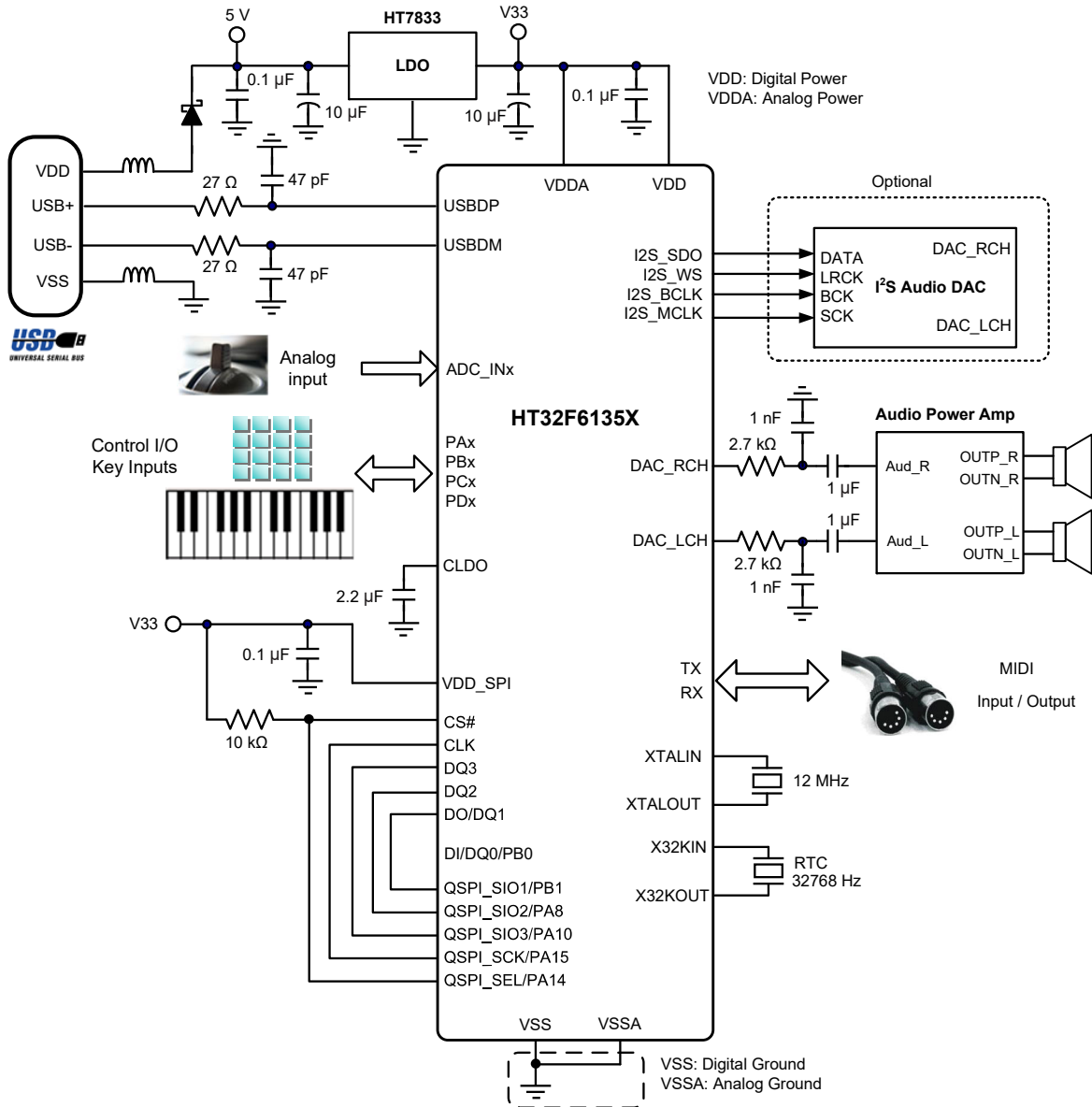

9 Electrical Characteristics

Absolute Maximum Ratings

The following table shows the absolute maximum ratings of the devices. These are stress ratings only. Stresses beyond absolute maximum ratings may cause permanent damage to the devices. Note that the devices are not guaranteed to operate properly at the maximum ratings. Exposure to the absolute maximum rating conditions for extended periods may affect device reliability.

Table 7. Absolute Maximum Ratings

| Symbol | Parameter | Min. | Max. | Unit |
|------------------|---|------------------------|------------------------|------|
| V _{DD} | External Main Supply Voltage | V _{SS} - 0.3 | V _{SS} + 3.6 | V |
| V _{DDA} | External Analog Supply Voltage | V _{SSA} - 0.3 | V _{SSA} + 3.6 | V |
| V _{IN} | Input Voltage on I/O | V _{SS} - 0.3 | V _{SS} + 0.3 | V |
| T _A | Ambient Operating Temperature Range | -40 | +85 | °C |
| T _{STG} | Storage Temperature Range | -55 | +150 | °C |
| T _J | Maximum Junction Temperature | — | +125 | °C |
| P _D | Total Power Dissipation | — | 500 | mW |
| V _{ESD} | Electrostatic Discharge Voltage – Human Body Mode | -4000 | +4000 | V |

Recommended DC Operating Conditions

Table 8. Recommended DC Operating Conditions

T_A = 25 °C, unless otherwise specified.

| Symbol | Parameter | Conditions | Min. | Typ. | Max. | Unit |
|------------------|--------------------------|------------|------|------|------|------|
| V _{DD} | I/O Operating Voltage | — | 2.0 | 3.3 | 3.6 | V |
| V _{DDA} | Analog Operating Voltage | — | 2.5 | 3.3 | 3.6 | V |

On-Chip LDO Voltage Regulator Characteristics

Table 9. LDO Characteristics

T_A = 25 °C, unless otherwise specified.

| Symbol | Parameter | Conditions | Min. | Typ. | Max. | Unit |
|------------------|--|--|-------|------|------|------|
| V _{LDO} | Internal Regulator Output Voltage | V _{DD} ≥ 2.0 V Regulator input @ I _{LDO} = 35 mA and voltage variant = ±5 %, After trimming. | 1.425 | 1.5 | 1.57 | V |
| I _{LDO} | Output Current | V _{DD} = 2.0 V Regulator input @ V _{LDO} = 1.5 V | — | 30 | 35 | mA |
| C _{LDO} | External Filter Capacitor Value for Internal Core Power Supply | The capacitor value is dependent on the core power current consumption | — | 1 | — | μF |

Power Consumption

Table 10. Power Consumption Characteristics

$T_A = 25\text{ }^\circ\text{C}$, unless otherwise specified.

| Symbol | Parameter | Conditions | Min. | Typ. | Max. | Unit | |
|-----------------------------------|--|--|--------------------------|-------|--------|---------------|----|
| I_{DD} | Supply Current (Run Mode) | $V_{DD} = 3.3\text{ V}$, HSE = 8 MHz, PLL = 48 MHz, $f_{HCLK} = 48\text{ MHz}$, $f_{PCLK} = 48\text{ MHz}$ | All peripherals enabled | — | 18.84 | — | mA |
| | | | All peripherals disabled | — | 9.55 | — | |
| | Supply Current (Sleep Mode) | $V_{DD} = 3.3\text{ V}$, HSE off, PLL off, LSI on, $f_{HCLK} = 32\text{ kHz}$, $f_{PCLK} = 32\text{ kHz}$ | All peripherals enabled | — | 2.383 | — | mA |
| | | | All peripherals disabled | — | 22.0 | — | |
| | Supply Current (Deep-Sleep1 Mode) | $V_{DD} = 3.3\text{ V}$, All clock off (HSE/PLL/ f_{HCLK}), LDO in low power mode, LSI on, RTC on | All peripherals enabled | — | 11.914 | — | mA |
| | | | All peripherals disabled | — | 1.856 | — | |
| Supply Current (Deep-Sleep2 Mode) | $V_{DD} = 3.3\text{ V}$, All clock off (HSE/PLL/ f_{HCLK}), LDO off, DMOS on, LSI on, RTC on | | — | 4.686 | — | μA | |
| Supply Current (Power-Down Mode) | $V_{DD} = 3.3\text{ V}$, LDO off, DMOS off, LSE on, LSI on, RTC on | | — | 2.636 | — | μA | |
| | | $V_{DD} = 3.3\text{ V}$, LDO off, DMOS off, LSE off, LSI on, RTC off | — | 1.236 | — | | |

- Notes: 1. HSE means high speed external oscillator. HSI means 8 MHz high speed internal oscillator.
2. LSE means 32.768 kHz low speed external oscillator. LSI means 32 kHz low speed internal oscillator.
3. RTC means real time clock.
4. Code = while (1) { 208 NOP } executed in Flash.

Reset and Supply Monitor Characteristics

Table 11. V_{DD} Power Reset Characteristics

$T_A = 25\text{ }^\circ\text{C}$, unless otherwise specified.

| Symbol | Parameter | Conditions | Min. | Typ. | Max. | Unit |
|---------------|---|--|------|------|------|------|
| V_{POR} | Power-on Reset Threshold (Rising Voltage on V_{DD}) | $T_A = -40\text{ }^\circ\text{C} \sim +85\text{ }^\circ\text{C}$ | 1.66 | 1.79 | 1.90 | V |
| V_{PDR} | Power-down Reset Threshold (Falling Voltage on V_{DD}) | | 1.49 | 1.64 | 1.78 | V |
| $V_{PORHYST}$ | POR Hysteresis | — | — | 150 | — | mV |
| t_{POR} | Reset Delay Time | $V_{DD} = 3.3\text{ V}$ | — | 0.1 | 0.2 | ms |

- Notes: 1. Data based on characterization results only, not tested in production.
2. Guaranteed by design, not tested in production.
3. If the LDO is turned on, the V_{DD} POR has to be in the de-assertion condition. When the V_{DD} POR is in the assertion state then the LDO will be turned off.

Table 12. LVD/BOD Characteristics

T_A = 25 °C, unless otherwise specified.

| Symbol | Parameter | Conditions | Min. | Typ. | Max. | Unit | |
|----------------------|----------------------------------|--|------------|------|------|-------|---|
| V _{BOD} | Voltage of Brown Out Detection | T _A = -40 °C ~ 85 °C After factory-trimmed (V _{DD} Falling edge) | 2.02 | 2.1 | 2.18 | V | |
| V _{LVD} | Voltage of Low Voltage Detection | T _A = -40 °C ~ 85 °C (V _{DD} Falling edge) | LVDS = 000 | 2.17 | 2.25 | 2.33 | V |
| | | | LVDS = 001 | 2.32 | 2.4 | 2.48 | |
| | | | LVDS = 010 | 2.47 | 2.55 | 2.63 | |
| | | | LVDS = 011 | 2.62 | 2.7 | 2.78 | |
| | | | LVDS = 100 | 2.77 | 2.85 | 2.93 | |
| | | | LVDS = 101 | 2.92 | 3.0 | 3.08 | |
| | | | LVDS = 110 | 3.07 | 3.15 | 3.23 | |
| LVDS = 111 | 3.22 | 3.3 | 3.38 | | | | |
| V _{LVDHTST} | LVD Hysteresis | V _{DD} = 3.3 V | — | — | 100 | mV | |
| t _{suLVD} | LVD Setup Time | V _{DD} = 3.3 V | — | — | — | 5 μs | |
| t _{aiLVD} | LVD Active Delay Time | V _{DD} = 3.3 V | — | — | — | μs | |
| I _{DDLVD} | Operation Current ⁽³⁾ | V _{DD} = 3.3 V | — | — | 5 | 15 μA | |

- Notes: 1. Data based on characterization results only, not tested in production.
2. Guaranteed by design, not tested in production.
3. Bandgap current is not included.
4. LVDS field is in the PWRCU LVDCSR register

External Clock Characteristics

Table 13. High Speed External Clock (HSE) Characteristics

T_A = 25 °C, unless otherwise specified.

| Symbol | Parameter | Conditions | Min. | Typ. | Max. | Unit |
|---------------------|--|--|------|------|------|------|
| V _{DD} | Operation Range | — | 2.0 | — | 3.6 | V |
| f _{HSE} | High Speed External Oscillator Frequency (HSE) | — | 4 | — | 16 | MHz |
| C _{LHSE} | Load Capacitance | V _{DD} = 3.3 V, R _{ESR} = 100 Ω @ 16 MHz | — | — | 22 | pF |
| R _{FHSE} | Internal Feedback Resistor between XTALIN and XTALOUT Pins | — | — | 1 | — | MΩ |
| R _{ESR} | Equivalent Series Resistance | V _{DD} = 3.3 V, C _L = 12 pF @ 16 MHz, HSEDR = 0 | — | — | 160 | Ω |
| | | V _{DD} = 2.4 V, C _L = 12 pF @ 16 MHz, HSEDR = 1 | | | | |
| D _{HSE} | HSE Oscillator Duty cycle | — | 40 | — | 60 | % |
| I _{DDHSE} | HSE Oscillator Current Consumption | V _{DD} = 3.3 V @ 16 MHz | — | TBD | — | mA |
| I _{PWDHSE} | HSE Oscillator Power Down Current | V _{DD} = 3.3 V | — | — | 0.01 | μA |
| t _{suHSE} | HSE Oscillator Startup Time | V _{DD} = 3.3 V | — | — | 4 | ms |

Table 14. Low Speed External Clock (LSE) Characteristics

$T_A = 25\text{ }^\circ\text{C}$, unless otherwise specified.

| Symbol | Parameter | Conditions | Min. | Typ. | Max. | Unit |
|---------------|---|---|------|--------|------|---------------|
| V_{BAK} | Operation Range | — | 2.0 | — | 3.6 | V |
| f_{CK_LSE} | LSE Frequency | $V_{BAK} = 2.0\text{ V} \sim 3.6\text{ V}$ | — | 32.768 | — | kHz |
| R_F | Internal Feedback Resistor | — | — | 10 | — | M Ω |
| R_{ESR} | Equivalent Series Resistance | $V_{BAK} = 3.3\text{ V}$ | 30 | — | TBD | k Ω |
| C_L | Recommended Load Capacitances | $V_{BAK} = 3.3\text{ V}$ | 6 | — | TBD | pF |
| I_{DDLSE} | Oscillator Supply Current (High Current Mode) | $f_{CK_LSE} = 32.768\text{ kHz}$, $R_{ESR} = 50\text{ k}\Omega$, $C_L \geq 7\text{ pF}$ $V_{BAK} = 2.0\text{ V} \sim 2.7\text{ V}$ $T_A = -40\text{ }^\circ\text{C} \sim +85\text{ }^\circ\text{C}$ | — | 3.3 | 6.3 | μA |
| | Oscillator Supply Current (Low Current Mode) | $f_{CK_LSE} = 32.768\text{ kHz}$, $R_{ESR} = 50\text{ k}\Omega$, $C_L < 7\text{ pF}$ $V_{BAK} = 2.0\text{ V} \sim 3.6\text{ V}$ $T_A = -40\text{ }^\circ\text{C} \sim +85\text{ }^\circ\text{C}$ | — | 1.8 | 3.3 | μA |
| | Power Down Current | — | — | — | 0.01 | μA |
| t_{suLSE} | Startup Time (Low Current Mode) | $f_{CK_LSI} = 32.768\text{ kHz}$, $V_{BAK} = 2.0\text{ V} \sim 3.6\text{ V}$ | 500 | — | — | ms |

Note: The following guidelines are recommended to increase the stability of the crystal circuit of the HSE / LSE clock in the PCB layout:

1. The crystal oscillator should be located as close as possible to the MCU to keep the trace lengths as short as possible to reduce any parasitic capacitance.
2. Shield lines in the vicinity of the crystal by using a ground plane to isolate signals and reduce noise.
3. Keep any high frequency signal lines away from the crystal area to prevent any crosstalk adverse effects.

Internal Clock Characteristics

Table 15. High Speed Internal Clock (HSI) Characteristics

$T_A = 25\text{ }^\circ\text{C}$, unless otherwise specified.

| Symbol | Parameter | Conditions | Min. | Typ. | Max. | Unit |
|-------------|--|---|------|------|------|---------------|
| V_{DD} | Operation Range | — | 2.0 | — | 3.6 | V |
| f_{HSI} | HSI Frequency | $V_{DD} = 3.3\text{ V} @ 25\text{ }^\circ\text{C}$ | — | 8 | — | MHz |
| ACC_{HSI} | Factory Calibrated HSI Oscillator Frequency Accuracy | $V_{DD} = 3.3\text{ V}$ $T_A = 25\text{ }^\circ\text{C}$ | -2 | — | 2 | % |
| | | $V_{DD} = 2.5\text{ V} \sim 3.6\text{ V}$, $T_A = -40\text{ }^\circ\text{C} \sim +85\text{ }^\circ\text{C}$ | -3 | — | 3 | % |
| | | $V_{DD} = 2.0\text{ V} \sim 3.6\text{ V}$ $T_A = -40\text{ }^\circ\text{C} \sim +85\text{ }^\circ\text{C}$ | -4 | — | 4 | % |
| Duty | Duty Cycle | $f_{HSI} = 8\text{ MHz}$ | 35 | — | 65 | % |
| I_{DDHSI} | Oscillator Supply Current | $f_{HSI} = 8\text{ MHz}$ | — | 300 | 500 | μA |
| | Power Down Current | | — | — | 0.05 | μA |
| t_{suHSI} | Startup Time | $f_{HSI} = 8\text{ MHz}$ | — | — | 10 | μs |

Table 16. Low Speed Internal Clock (LSI) Characteristics

$T_A = 25\text{ }^\circ\text{C}$, unless otherwise specified.

| Symbol | Parameter | Conditions | Min. | Typ. | Max. | Unit |
|-------------|---|---|------|------|------|---------------|
| f_{LSI} | Low Speed Internal Oscillator Frequency (LSI) | $V_{DD} = 3.3\text{ V}$, $T_A = -40\text{ }^\circ\text{C} \sim +85\text{ }^\circ\text{C}$ | 21 | 32 | 43 | kHz |
| ACC_{LSI} | LSI Frequency Accuracy | After factory-trimmed, $V_{DD} = 3.3\text{ V}$, $T_A = 25\text{ }^\circ\text{C}$ | -10 | — | +10 | % |
| I_{DDLSI} | LSI Oscillator Operating Current | $V_{DD} = 3.3\text{ V}$, $T_A = 25\text{ }^\circ\text{C}$ | — | 0.4 | 0.8 | μA |
| t_{SULSI} | LSI Oscillator Startup Time | $V_{DD} = 3.3\text{ V}$, $T_A = 25\text{ }^\circ\text{C}$ | — | — | 100 | μs |

PLL Characteristics

Table 17. PLL Characteristics

$T_A = 25\text{ }^\circ\text{C}$, unless otherwise specified.

| Symbol | Parameter | Conditions | Min. | Typ. | Max. | Unit |
|---------------|------------------|------------|------|------|------|---------------|
| f_{PLLIN} | PLL input clock | — | 4 | — | 16 | MHz |
| f_{CK_PLL} | PLL output clock | — | 16 | — | 48 | MHz |
| t_{LOCK} | PLL lock time | — | — | 200 | — | μs |

Memory Characteristics

Table 18. Flash Memory Characteristics

$T_A = 25\text{ }^\circ\text{C}$, unless otherwise specified.

| Symbol | Parameter | Conditions | Min. | Typ. | Max. | Unit |
|--------------|---|--|------|------|------|---------------|
| N_{ENDU} | Number of Guaranteed Program/Erase Cycles before Failure. (Endurance) | $T_A = -40\text{ }^\circ\text{C} \sim +85\text{ }^\circ\text{C}$ | 10 | — | — | K cycles |
| t_{RET} | Data Retention Time | $T_A = -40\text{ }^\circ\text{C} \sim +85\text{ }^\circ\text{C}$ | 10 | — | — | Years |
| t_{PROG} | Word Programming Time | $T_A = -40\text{ }^\circ\text{C} \sim +85\text{ }^\circ\text{C}$ | 20 | — | — | μs |
| t_{ERASE} | Page Erase Time | $T_A = -40\text{ }^\circ\text{C} \sim +85\text{ }^\circ\text{C}$ | 2 | — | — | ms |
| t_{MERASE} | Mass Erase Time | $T_A = -40\text{ }^\circ\text{C} \sim +85\text{ }^\circ\text{C}$ | 10 | — | — | ms |

I/O Port Characteristics

Table 19. I/O Port Characteristics

$T_A = 25\text{ }^\circ\text{C}$, unless otherwise specified.

| Symbol | Parameter | Conditions | Min. | Typ. | Max. | Unit | |
|----------|--------------------------|------------|---|------|----------------------|------|---------------|
| I_{IL} | Low Level Input Current | 3.3 V I/O | $V_I = V_{SS}$, On-chip pull-up resistor disabled. | — | — | 3 | μA |
| | | Reset pin | | — | — | 3 | μA |
| I_{IH} | High Level Input Current | 3.3 V I/O | $V_I = V_{DD}$, On-chip pull-down resistor disabled. | — | — | 3 | μA |
| | | Reset pin | | — | — | 3 | μA |
| V_{IL} | Low Level Input Voltage | 3.3 V I/O | — | — | $V_{DD} \times 0.35$ | V | |
| | | Reset pin | - 0.5 | — | $V_{DD} \times 0.35$ | V | |

| Symbol | Parameter | Conditions | Min. | Typ. | Max. | Unit |
|------------------|---|--|------------------------|------------------------|-----------------------|------|
| V _{IH} | High Level Input Voltage | 3.3 V I/O | V _{DD} × 0.65 | — | V _{DD} + 0.5 | V |
| | | Reset pin | V _{DD} × 0.65 | — | V _{DD} + 0.5 | V |
| V _{HYS} | Schmitt Trigger Input Voltage Hysteresis | 3.3 V I/O | — | 0.12 × V _{DD} | — | mV |
| | | Reset pin | — | 0.12 × V _{DD} | — | |
| I _{OL} | Low Level Output Current (GPIO Sink Current) | 3.3 V I/O 4 mA drive, V _{OL} = 0.4 V | 4 | — | — | mA |
| | | 3.3 V I/O 8 mA drive, V _{OL} = 0.4 V | 8 | — | — | |
| | | 3.3 V I/O 12 mA drive, V _{OL} = 0.4 V | 12 | — | — | |
| | | 3.3 V I/O 16 mA drive, V _{OL} = 0.4 V | 16 | — | — | |
| I _{OH} | High Level Output Current (GPIO Source Current) | 3.3 V I/O 4 mA drive, V _{OH} = V _{DD} - 0.4 V | 4 | — | — | mA |
| | | 3.3 V I/O 8 mA drive, V _{OH} = V _{DD} - 0.4 V | 8 | — | — | |
| | | 3.3 V I/O 12 mA drive, V _{OH} = V _{DD} - 0.4 V | 12 | — | — | |
| | | 3.3 V I/O 16 mA drive, V _{OH} = V _{DD} - 0.4 V | 16 | — | — | |
| V _{OL} | Low Level Output Voltage | 3.3 V 4 mA drive I/O, I _{OL} = 4 mA | — | — | 0.4 | V |
| | | 3.3 V 8 mA drive I/O, I _{OL} = 8 mA | — | — | 0.4 | |
| | | 3.3 V 12 mA drive I/O, I _{OL} = 12 mA | — | — | 0.4 | |
| | | 3.3 V 16 mA drive I/O, I _{OL} = 16 mA | — | — | 0.4 | |
| V _{OH} | High Level Output Voltage | 3.3 V 4 mA drive I/O, I _{OH} = 4 mA | V _{DD} - 0.4 | — | — | V |
| | | 3.3 V 8 mA drive I/O, I _{OH} = 8 mA | V _{DD} - 0.4 | — | — | |
| | | 3.3 V 12 mA drive I/O, I _{OH} = 12 mA | V _{DD} - 0.4 | — | — | |
| | | 3.3 V 16 mA drive I/O, I _{OH} = 16 mA | V _{DD} - 0.4 | — | — | |
| R _{PU} | Internal Pull-up Resistor | 3.3 V I/O | — | 46 | — | kΩ |
| R _{PD} | Internal Pull-down Resistor | 3.3 V I/O | — | 46 | — | kΩ |

ADC Characteristics

Table 20. ADC Characteristics

$T_A = 25\text{ }^\circ\text{C}$, unless otherwise specified.

| Symbol | Parameter | Conditions | Min. | Typ. | Max. | Unit |
|---------------|-----------------------------------|---|------|-----------|------------|-----------------------|
| V_{DDA} | Operating Voltage | — | 2.7 | 3.3 | 3.6 | V |
| V_{ADCIN} | A/D Converter Input Voltage Range | — | 0 | — | V_{REF+} | V |
| V_{REF+} | A/D Converter Reference Voltage | — | — | V_{DDA} | V_{DDA} | V |
| I_{ADC} | Current Consumption | $V_{DDA} = 3.3\text{ V}$, 1 Msps | — | 0.9 | 1.0 | mA |
| I_{ADC_DN} | Power Down Current Consumption | $V_{DDA} = 3.3\text{ V}$ | — | — | 0.1 | μA |
| f_{ADC} | A/D Converter Clock | — | 0.7 | — | 16 | MHz |
| f_S | Sampling Rate | — | 0.05 | — | 1 | MHz |
| t_{DL} | Data Latency | — | — | 12.5 | — | $1/f_{ADC}$ Cycles |
| $t_{S\&H}$ | Sampling & Hold Time | — | — | 3.5 | — | $1/f_{ADC}$ Cycles |
| $t_{ADCCONV}$ | A/D Converter Conversion Time | — | — | 16 | — | $1/f_{ADC}$ Cycles |
| R_i | Input Sampling Switch Resistance | — | — | — | 1 | k Ω |
| C_i | Input Sampling Capacitance | No pin/pad capacitance included | — | 16 | — | pF |
| t_{SU} | Startup up Time | — | — | — | 1 | μs |
| N | Resolution | — | — | 12 | — | bit |
| INL | Integral Non-linearity Error | $f_S = 750\text{ kHz}$, $V_{DDA} = 3.3\text{ V}$ | — | ± 2 | ± 5 | LSB |
| DNL | Differential Non-linearity Error | $f_S = 750\text{ kHz}$, $V_{DDA} = 3.3\text{ V}$ | — | ± 1 | — | LSB |
| E_o | Offset Error | — | — | — | ± 10 | LSB |
| E_G | Gain Error | — | — | — | ± 10 | LSB |

Notes: 1. Guaranteed by design, not tested in production.

2. The figure below shows the equivalent circuit of the A/D Converter Sample-and-Hold input stage where C_i is the storage capacitor, R_i is the resistance of the sampling switch and R_S is the output impedance of the signal source V_S . Normally the sampling phase duration is approximately, $3.5/f_{ADC}$. The capacitance, C_i , must be charged within this time frame and it must be ensured that the voltage at its terminals becomes sufficiently close to V_S for accuracy. To guarantee this, R_S is not allowed to have an arbitrarily large value.

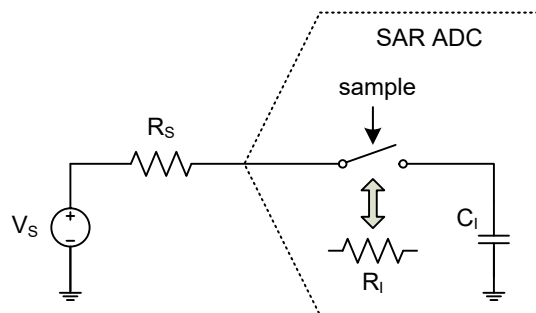

Figure 8. ADC Sampling Network Model

The worst case occurs when the extremities of the input range (0 V and V_{REF}) are sampled consecutively. In this situation a sampling error below $\frac{1}{4}$ LSB is ensured by using the following equation:

$$R_s < \frac{3.5}{f_{ADC} C_1 \ln(2^{N+2})} - R_1$$

Where f_{ADC} is the ADC clock frequency and N is the ADC resolution (N = 12 in this case). A safe margin should be considered due to the pin/pad parasitic capacitances, which are not accounted for in this simple model.

If, in a system where the A/D Converter is used, there are no rail-to-rail input voltage variations between consecutive sampling phases, R_s may be larger than the value indicated by the equation above.

SCTM/GPTM Characteristics

Table 21. SCTM/GPTM Characteristics

| Symbol | Parameter | Conditions | Min. | Typ. | Max. | Unit |
|-----------|--|------------|------|------|------|------------|
| f_{TM} | Timer Clock Source for GPTM | — | — | — | 48 | MHz |
| t_{RES} | Timer Resolution Time | — | 1 | — | — | $1/f_{TM}$ |
| f_{EXT} | External Signal Frequency On Channel 1 ~ 4 | — | — | — | 1/2 | f_{TM} |
| RES | Timer Resolution | — | — | — | 16 | bit |

I²C Characteristics

Table 22. I²C Characteristics

| Symbol | Parameter | Standard Mode | | Fast Mode | | Fast Plus Mode | | Unit |
|---------------|----------------------------|---------------|------|-----------|------|----------------|-------|---------|
| | | Min. | Max. | Min. | Max. | Min. | Max. | |
| f_{SCL} | SCL Clock Frequency | — | 100 | — | 400 | — | 1000 | kHz |
| $t_{SCL(H)}$ | SCL Clock High Time | 4.5 | — | 1.125 | — | 0.45 | — | μ s |
| $t_{SCL(L)}$ | SCL Clock Low Time | 4.5 | — | 1.125 | — | 0.45 | — | μ s |
| t_{FALL} | SCL and SDA Fall Time | — | 1.3 | — | 0.34 | — | 0.135 | μ s |
| t_{RISE} | SCL and SDA Rise Time | — | 1.3 | — | 0.34 | — | 0.135 | μ s |
| $t_{SU(SDA)}$ | SDA Data Setup Time | 500 | — | 125 | — | 50 | — | ns |
| $t_{H(SDA)}$ | SDA Data Hold Time | 0 | — | 0 | — | 0 | — | ns |
| $t_{SU(STA)}$ | START Condition Setup Time | 500 | — | 125 | — | 50 | — | ns |
| $t_{H(STA)}$ | START Condition Hold Time | 0 | — | 0 | — | 0 | — | ns |
| $t_{SU(STO)}$ | STOP Condition Setup Time | 500 | — | 125 | — | 50 | — | ns |

- Notes: 1. Guaranteed by design, not tested in production.
2. To achieve 100 kHz standard mode, the peripheral clock frequency must be higher than 2 MHz.
3. To achieve 400 kHz fast mode, the peripheral clock frequency must be higher than 8 MHz.
4. To achieve 1 MHz fast mode plus, the peripheral clock frequency must be higher than 20 MHz.
5. The above characteristic parameters of the I²C bus timing are based on: SEQFILTER = 01 and COMBFILTEREn is disabled.

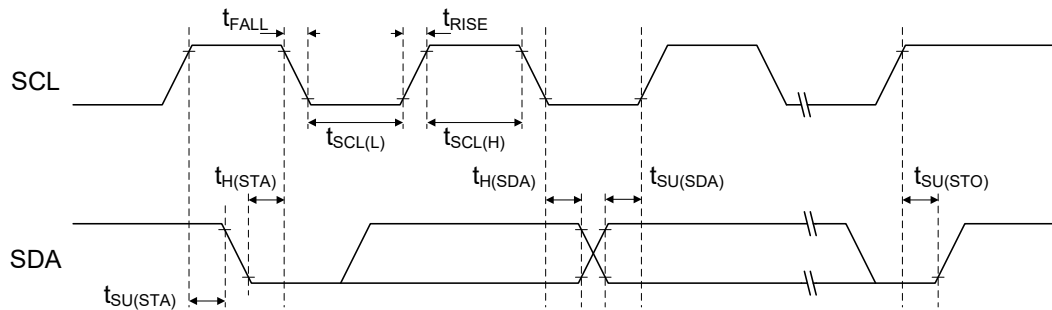

Figure 9. I²C Timing Diagrams

I²S Characteristics

Table 23. I²S Characteristics

| Symbol | Parameter | Conditions | Min. | Typ. | Max. | Unit |
|------------------------|---------------------------|------------|------|------|------|------|
| I²S Master Mode | | | | | | |
| $t_{WSD(MO)}$ | WS Output to BCLK Delay | — | — | TBD | — | ns |
| $t_{DOD(MO)}$ | Data Output to BCLK Delay | — | — | TBD | — | ns |
| $t_{DIS(MI)}$ | Data Input Setup Time | — | — | TBD | — | ns |
| $t_{DIH(MI)}$ | Data Input Hold Time | — | — | TBD | — | ns |
| I²S Slave Mode | | | | | | |
| $t_{BCH(SI)}$ | BCLK High Pulse Width | — | — | TBD | — | ns |
| $t_{BCL(SI)}$ | BCLK Low Pulse Width | — | — | TBD | — | ns |
| $t_{WSS(SI)}$ | WS Input Setup Time | — | — | TBD | — | ns |
| $t_{DOD(SO)}$ | Data Output to BCLK Delay | — | — | TBD | — | ns |
| $t_{DIS(SI)}$ | Data Input Setup Time | — | — | TBD | — | ns |
| $t_{DIH(SI)}$ | Data Input Hold Time | — | — | TBD | — | ns |

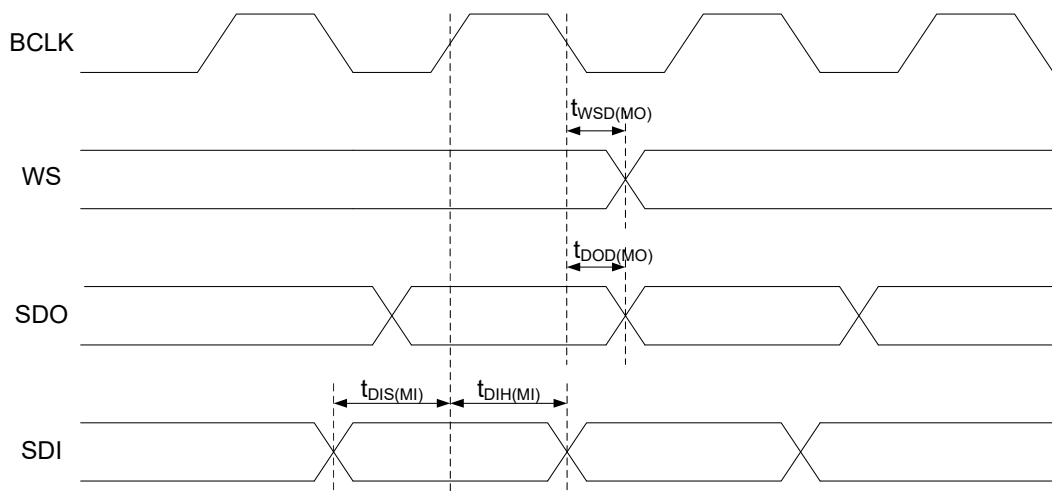

Figure 10. Timing of I²S Master Mode

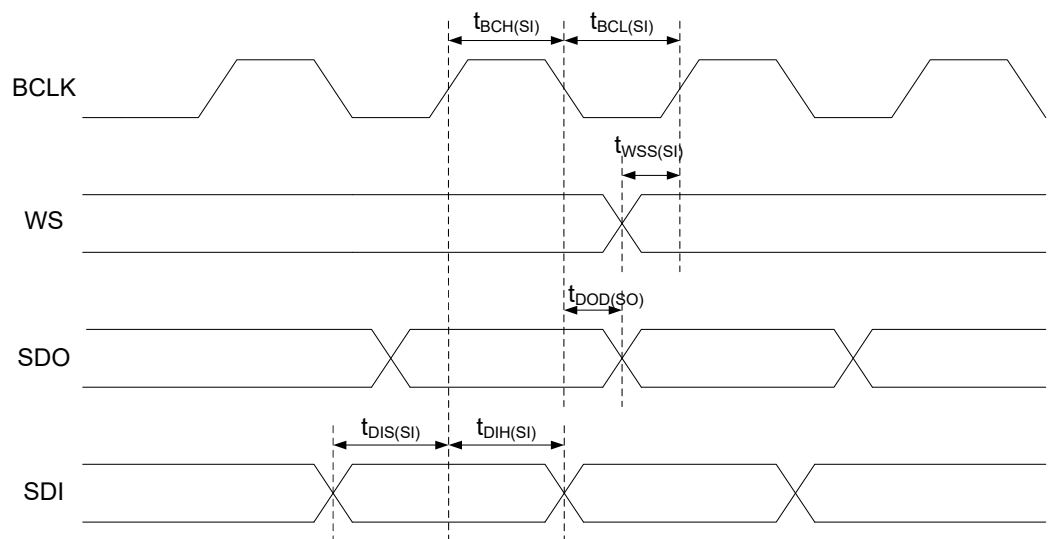

Figure 11. Timing of I²S Slave Mode

SPI Characteristics

Table 24. SPI Characteristics

| Symbol | Parameter | Conditions | Min. | Typ. | Max. | Unit |
|------------------------------|---------------------------------------|---|---------------------|------|---------------------|------|
| SPI Master Mode | | | | | | |
| f_{SCK} ($1/t_{SCK}$) | SPI Master Output SCK Clock Frequency | Master mode SPI peripheral clock frequency f_{PCLK} | — | — | $f_{PCLK}/2$ | MHz |
| $t_{SCK(H)}$ $t_{SCK(L)}$ | SCK Clock High and Low Time | — | $t_{SCK}/2 - 2$ | — | $t_{SCK}/2 + 1$ | ns |
| $t_{V(MO)}$ | Data Output Valid Time | — | — | — | 5 | ns |
| $t_{H(MO)}$ | Data Output Hold Time | — | 2 | — | — | ns |
| $t_{SU(MI)}$ | Data Input Setup Time | — | 5 | — | — | ns |
| $t_{H(MI)}$ | Data Input Hold Time | — | 5 | — | — | ns |
| SPI Slave Mode | | | | | | |
| f_{SCK} ($1/t_{SCK}$) | SPI Slave Input SCK Clock Frequency | Slave Mode SPI peripheral clock frequency f_{PCLK} | — | — | $f_{PCLK}/3$ | MHz |
| Duty _{SCK} | SPI Slave Input SCK Clock Duty Cycle | — | 30 | — | 70 | % |
| $t_{SU(SEL)}$ | SEL Enable Setup Time | — | $3 \times t_{PCLK}$ | — | — | ns |
| $t_{H(SEL)}$ | SEL Enable Hold Time | — | $2 \times t_{PCLK}$ | — | — | ns |
| $t_{A(SO)}$ | Data Output Access Time | — | — | — | $3 \times t_{PCLK}$ | ns |
| $t_{DIS(SO)}$ | Data Output Disable Time | — | — | — | 10 | ns |
| $t_{V(SO)}$ | Data Output Valid Time | — | — | — | 25 | ns |
| $t_{H(SO)}$ | Data Output Hold Time | — | 15 | — | — | ns |
| $t_{SU(SI)}$ | Data Input Setup Time | — | 5 | — | — | ns |
| $t_{H(SI)}$ | Data Input Hold Time | — | 4 | — | — | ns |

Note: $t_{SCK} = 1/f_{SCK}$; $t_{PCLK} = 1/f_{PCLK}$. SPI output (input) clock frequency f_{SCK} ; SPI peripheral clock frequency f_{PCLK} .

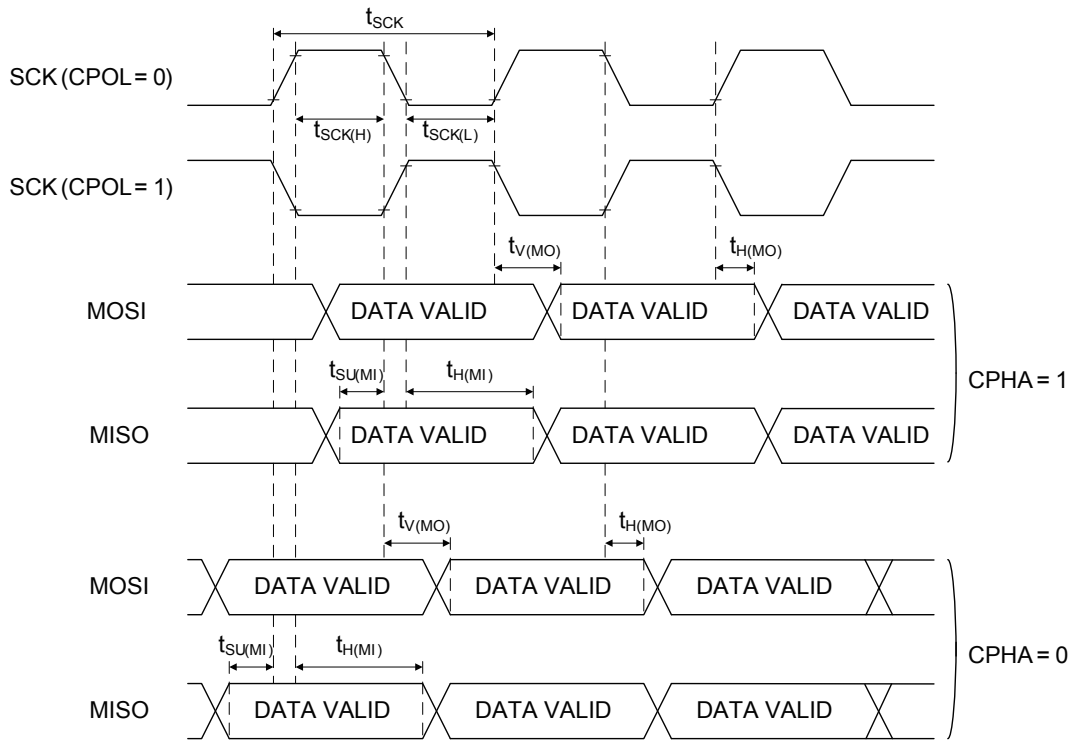

Figure 12. SPI Timing Diagrams – SPI Master Mode

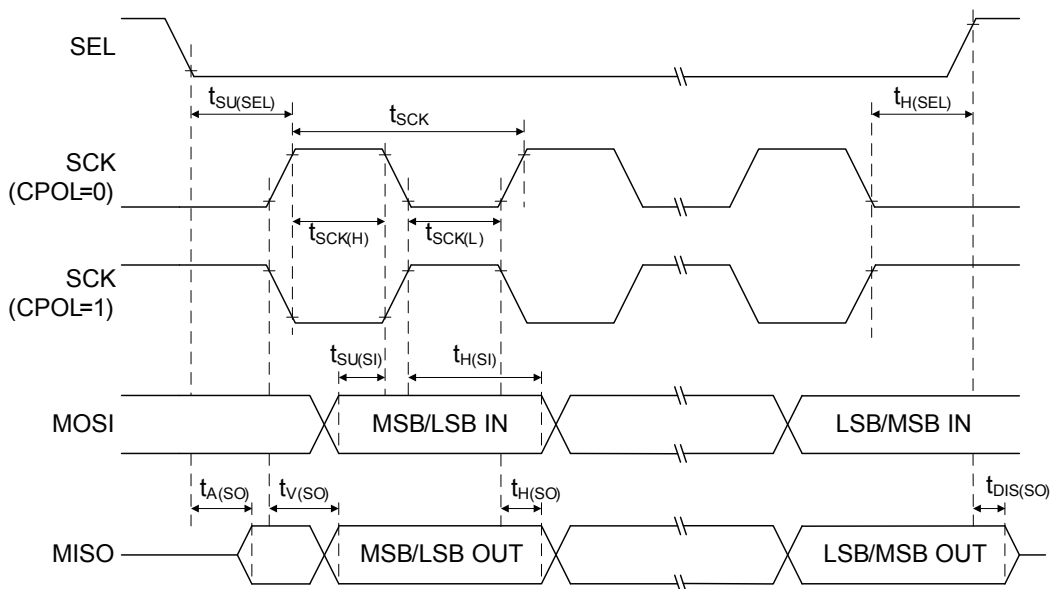

Figure 13. SPI Timing Diagrams – SPI Slave Mode with CPHA = 1

QSPI Characteristics

Table 25. QSPI Characteristics

| Symbol | Parameter | Conditions | Min. | Typ. | Max. | Unit |
|---|--|--|---------------------|------|---------------------|------|
| QSPI Master Mode | | | | | | |
| f_{SCK} ($1/t_{SCK}$) | QSPI Master Output SCK Clock Frequency | Master mode QSPI peripheral clock frequency f_{HCLK} | — | — | $f_{HCLK}/2$ | MHz |
| $t_{SCK(H)}$ $t_{SCK(L)}$ | SCK Clock High and Low Time | — | $t_{SCK}/2 - 2$ | — | $t_{SCK}/2 + 1$ | ns |
| $t_{V(MO)}$ | Data Output Valid Time | — | — | — | 5 | ns |
| $t_{H(MO)}$ | Data Output Hold Time | — | 2 | — | — | ns |
| $t_{SU(MI)}$ | Data Input Setup Time | — | 5 | — | — | ns |
| $t_{H(MI)}$ | Data Input Hold Time | — | 5 | — | — | ns |
| QSPI Slave Mode (1-bit Serial Mode Only) | | | | | | |
| f_{SCK} ($1/t_{SCK}$) | QSPI Slave Input SCK Clock Frequency | Slave mode QSPI peripheral clock frequency f_{HCLK} | — | — | $f_{HCLK}/3$ | MHz |
| Duty _{SCK} | QSPI Slave Input SCK Clock Duty Cycle | — | 30 | — | 70 | % |
| $t_{SU(SEL)}$ | SEL Enable Setup Time | — | $3 \times t_{HCLK}$ | — | — | ns |
| $t_{H(SEL)}$ | SEL Enable Hold Time | — | $2 \times t_{HCLK}$ | — | — | ns |
| $t_{A(SO)}$ | Data Output Access Time | — | — | — | $3 \times t_{HCLK}$ | ns |
| $t_{DIS(SO)}$ | Data Output Disable Time | — | — | — | 10 | ns |
| $t_{V(SO)}$ | Data Output Valid Time | — | — | — | 25 | ns |
| $t_{H(SO)}$ | Data Output Hold Time | — | 15 | — | — | ns |
| $t_{SU(SI)}$ | Data Input Setup Time | — | 5 | — | — | ns |
| $t_{H(SI)}$ | Data Input Hold Time | — | 4 | — | — | ns |

Note: $t_{SCK} = 1/f_{SCK}$; $t_{HCLK} = 1/f_{HCLK}$. QSPI output (input) clock frequency f_{SCK} ; QSPI peripheral clock frequency f_{HCLK} .

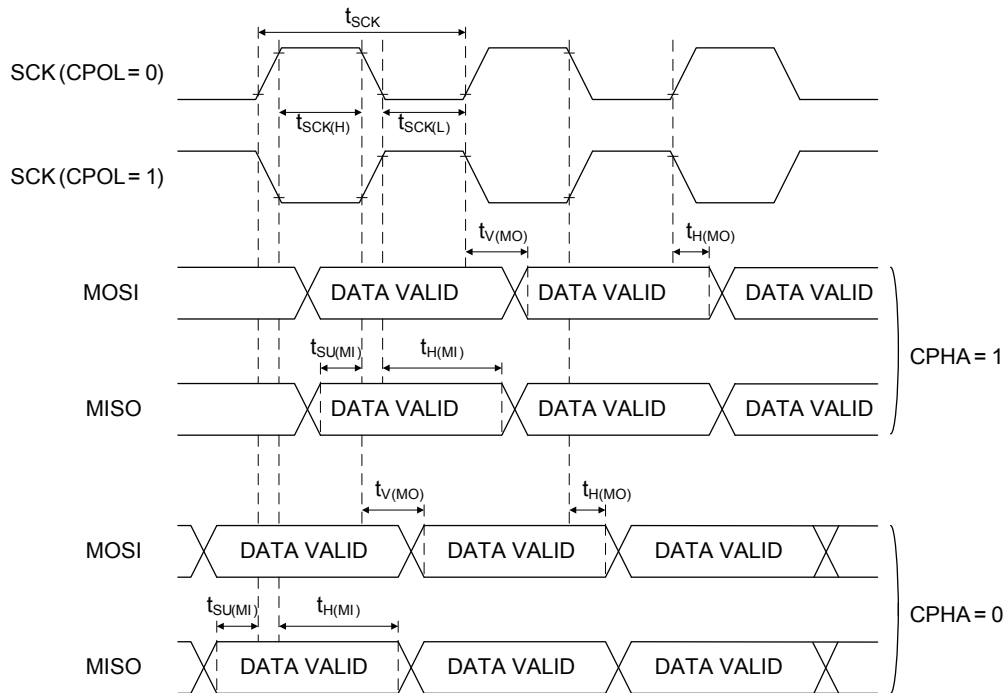

Figure 14. QSPI Timing Diagrams – QSPI Master Mode (1-bit Serial Mode, DUALEN = 0, QUADEN = 0)

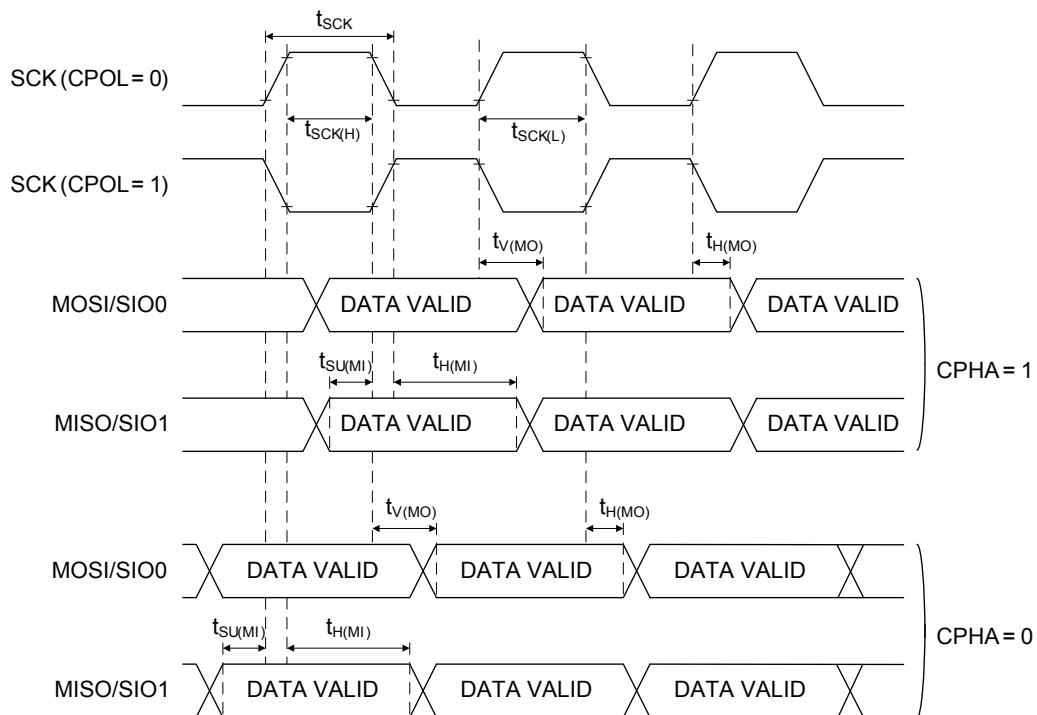

Figure 15. QSPI Timing Diagrams – QSPI Master Mode (Dual Mode, DUALEN = 1)

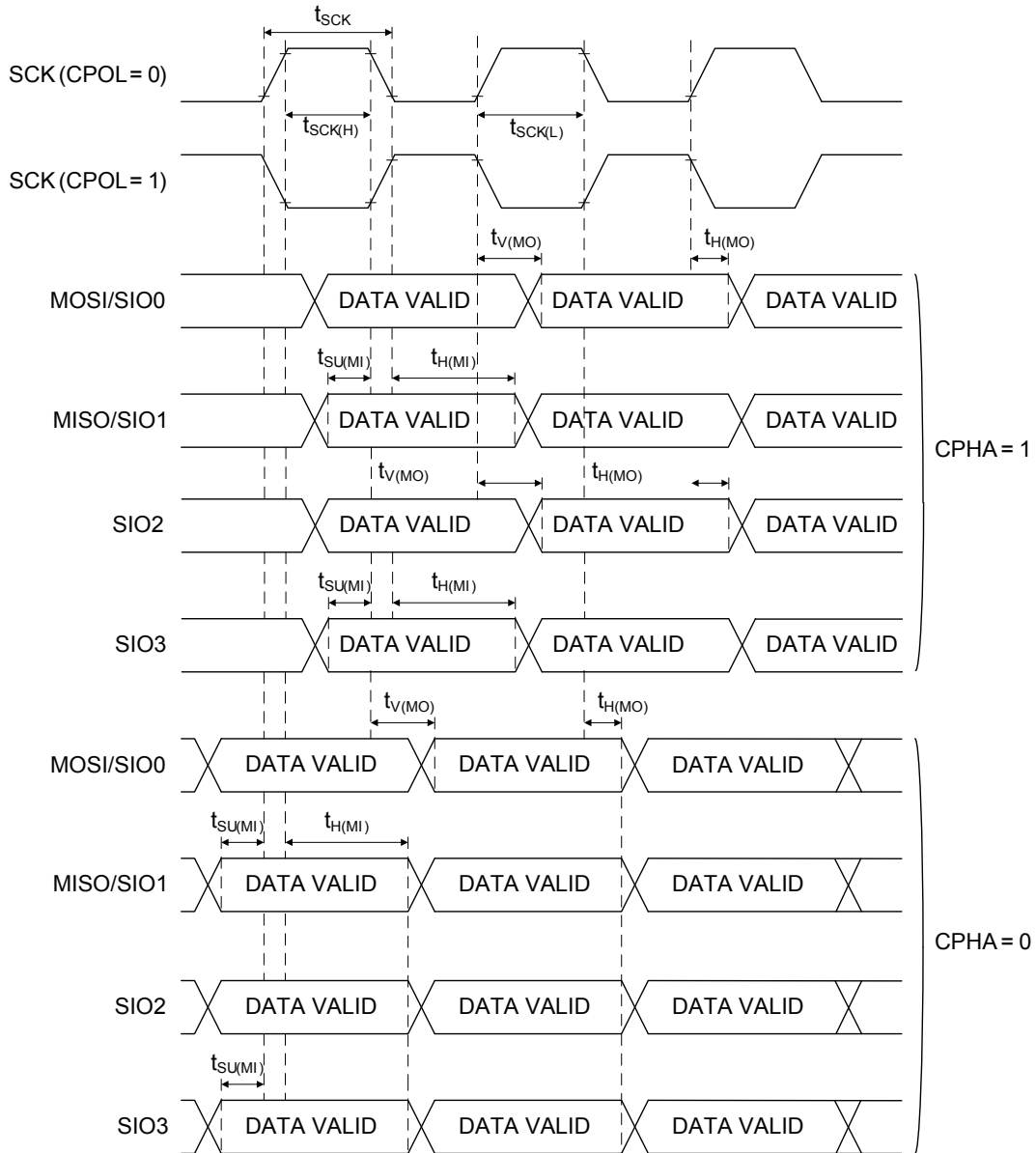

Figure 16. QSPI Timing Diagrams – QSPI Master Mode (Quad Mode, QUADEN = 1)

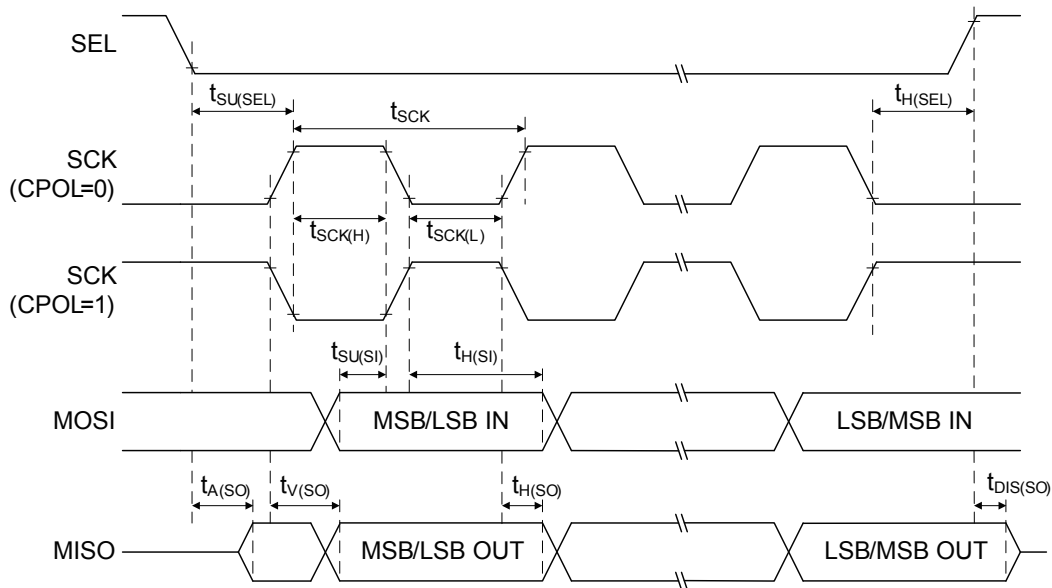

Figure 17. QSPI Timing Diagrams – QSPI Slave Mode with CPHA = 1 (1-bit Serial Mode)

USB Characteristics

The USB interface is USB-IF certified – Full Speed.

Table 26. USB DC Electrical Characteristics

| Symbol | Parameter | Conditions | Min. | Typ. | Max. | Unit |
|------------------|--|---|------|------|------|------|
| V _{DD} | USB Operating Voltage | — | 3.0 | — | 3.6 | V |
| V _{DI} | Differential Input Sensitivity | USBDP - USBDM | 0.2 | — | — | V |
| V _{CM} | Common Mode Voltage Range | — | 0.8 | — | 2.5 | V |
| V _{SE} | Single-ended Receiver Threshold | — | 0.8 | — | 2.0 | V |
| V _{OL} | Pad Output Low Voltage | R _L of 1.5 kΩ to V _{DD} | 0 | — | 0.3 | V |
| V _{OH} | Pad Output High Voltage | | 2.8 | — | 3.6 | V |
| V _{CRS} | Differential Output Signal Cross-point Voltage | | 1.3 | — | 2.0 | V |
| Z _{DRV} | Driver Output Resistance | — | — | 10 | — | Ω |
| C _{IN} | Transceiver Pad Capacitance | — | — | — | 20 | pF |

Notes: 1. Guaranteed by design, not tested in production.

2. The USB functionality is ensured down to 2.7 V but not the full USB electrical characteristics which will experience degradation in the 2.7-to-3.0 V V_{DD} voltage range.

3. R_L is the load connected to the USB driver USBDP.

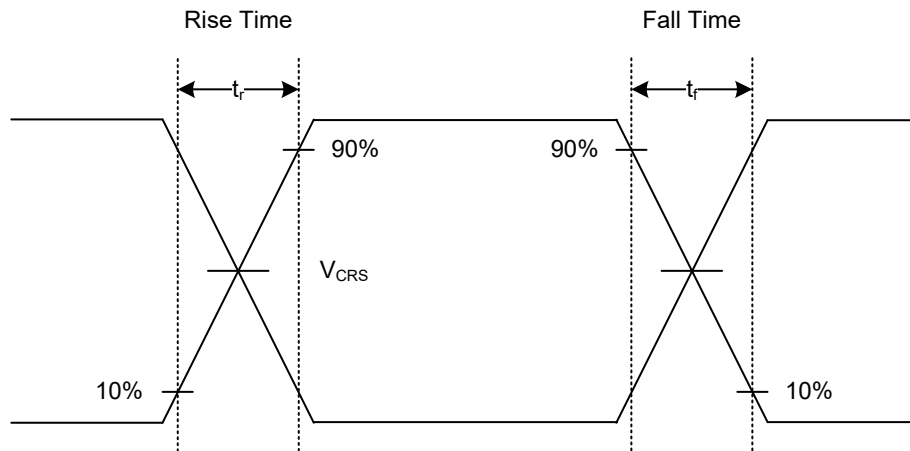

Figure 18. USB Signal Rise Time and Fall Time and Cross-Point Voltage (V_{CRS}) Definition

Table 27. USB AC Electrical Characteristics

| Symbol | Parameter | Conditions | Min. | Typ. | Max. | Unit |
|-----------|--------------------------------|-----------------------|------|------|------|------|
| t_r | Rise Time | $C_L = 50 \text{ pF}$ | 4 | — | 20 | ns |
| t_f | Fall Time | $C_L = 50 \text{ pF}$ | 4 | — | 20 | ns |
| $t_{r/f}$ | Rise Time / Fall Time Matching | $t_{r/f} = t_r / t_f$ | 90 | — | 110 | % |

Audio D/A Converter Characteristics

Table 28. Audio D/A Converter Characteristics

| Symbol | Parameter | Conditions | Min. | Typ. | Max. | Unit |
|----------|---|---|------|------|------|------|
| V_{DD} | Operating Voltage | — | 2.2 | — | 3.6 | V |
| I_{DD} | Operating Current | $V_{DD} = 3 \text{ V}$ | — | 3 | — | mA |
| THD+N | Total Harmonic Distortion + Noise ^(Note) | $V_{DD} = 3 \text{ V}$, 10 k Ω load | — | -50 | — | dB |

Note: Sine wave input @1 kHz, -6 dB.

SPI Flash Data Memory DC Characteristics

Table 29. SPI Flash Data Memory DC Characteristics

| Symbol | Parameter | Conditions | Min | Typ | Max | Unit |
|------------------|----------------------------------|--|-----------------------|-----|-----------------------|------|
| V _{DD} | Operating Voltage | — | 2.3 | — | 3.6 | V |
| I _{LI} | Input Leakage Current | — | — | 1 | ±2 | μA |
| I _{LO} | Output Leakage Current | — | — | 1 | ±2 | μA |
| I _{STB} | Standby Current | CS# = V _{CC} , V _{IN} = V _{DD} or V _{CC} | — | — | 2 | μA |
| I _{CC1} | Operating Current (Read) | CLK = 0.1 V _{CC} / 0.9 V _{DD} at 48 MHz, DQ = open | — | 6 | 14 | mA |
| | | CLK = 0.1 V _{CC} / 0.9 V _{DD} at 48 MHz, Quad Output Read, DQ = open | — | 8.5 | 20 | mA |
| I _{CC2} | Operating Current (Page Program) | CS# = V _{DD} | — | 9 | 30 | mA |
| V _{IL} | Input Low Voltage | — | -0.5 | — | 0.2 × V _{DD} | V |
| V _{IH} | Input High Voltage | — | 0.7 × V _{DD} | — | V _{DD} + 0.4 | V |
| V _{OL} | Output Low Voltage | I _{OL} = 100 μA, V _{DD} = V _{DD} Min. | — | — | 0.3 | V |
| V _{OH} | Output High Voltage | I _{OH} = -100 μA, V _{DD} = V _{DD} Min. | V _{DD} - 0.2 | — | — | V |

10 Package Information

Note that the package information provided here is for consultation purposes only. As this information may be updated at regular intervals users are reminded to consult the [Holtek website](#) for the latest version of the [package information](#).

Additional supplementary information with regard to packaging is listed below. Click on the relevant section to be transferred to the relevant website page.

- Further Package Information (include Outline Dimensions, Product Tape and Reel Specifications)
- Packing Materials Information
- Carton information

48-pin LQFP (7 mm × 7 mm) Outline Dimensions

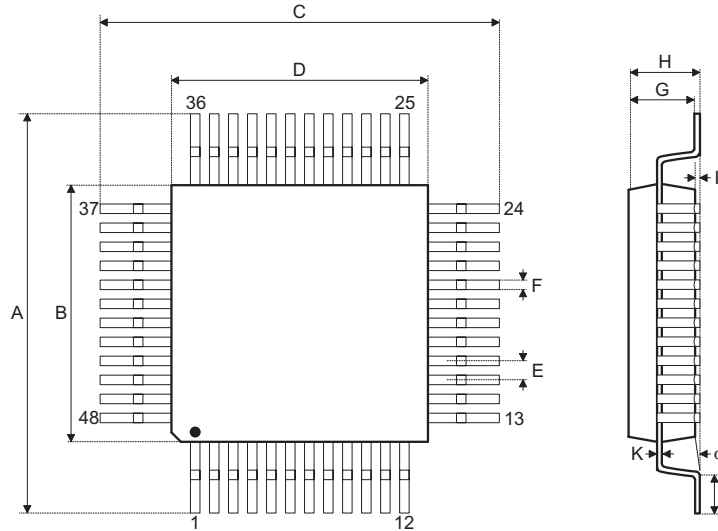

| Symbol | Dimensions in inch | | |
|--------|--------------------|-----------|-------|
| | Min. | Nom. | Max. |
| A | — | 0.354 BSC | — |
| B | — | 0.276 BSC | — |
| C | — | 0.354 BSC | — |
| D | — | 0.276 BSC | — |
| E | — | 0.020 BSC | — |
| F | 0.007 | 0.009 | 0.011 |
| G | 0.053 | 0.055 | 0.057 |
| H | — | — | 0.063 |
| I | 0.002 | — | 0.006 |
| J | 0.018 | 0.024 | 0.030 |
| K | 0.004 | — | 0.008 |
| α | 0° | — | 7° |

| Symbol | Dimensions in mm | | |
|--------|------------------|----------|------|
| | Min. | Nom. | Max. |
| A | — | 9.00 BSC | — |
| B | — | 7.00 BSC | — |
| C | — | 9.00 BSC | — |
| D | — | 7.00 BSC | — |
| E | — | 0.50 BSC | — |
| F | 0.17 | 0.22 | 0.27 |
| G | 1.35 | 1.40 | 1.45 |
| H | — | — | 1.60 |
| I | 0.05 | — | 0.15 |
| J | 0.45 | 0.60 | 0.75 |
| K | 0.09 | — | 0.20 |
| α | 0° | — | 7° |

64-pin LQFP (7 mm × 7 mm) Outline Dimensions

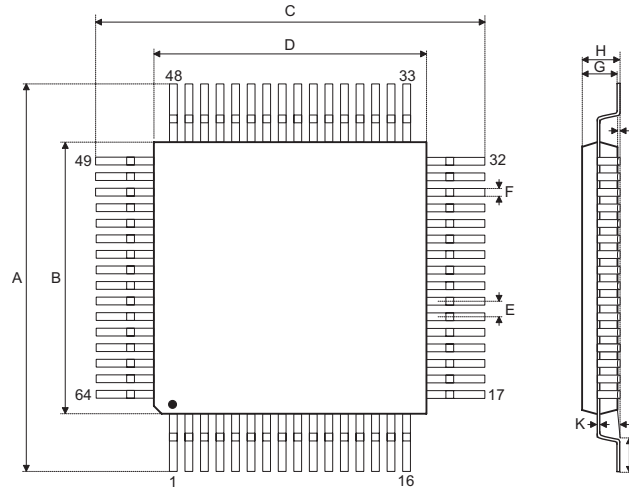

| Symbol | Dimensions in inch | | |
|----------|--------------------|-----------|-------|
| | Min. | Nom. | Max. |
| A | — | 0.354 BSC | — |
| B | — | 0.276 BSC | — |
| C | — | 0.354 BSC | — |
| D | — | 0.276 BSC | — |
| E | — | 0.016 BSC | — |
| F | 0.005 | 0.007 | 0.009 |
| G | 0.053 | 0.055 | 0.057 |
| H | — | — | 0.063 |
| I | 0.002 | — | 0.006 |
| J | 0.018 | 0.024 | 0.030 |
| K | 0.004 | — | 0.008 |
| α | 0° | — | 7° |

| Symbol | Dimensions in mm | | |
|----------|------------------|---------|------|
| | Min. | Nom. | Max. |
| A | — | 9.0 BSC | — |
| B | — | 7.0 BSC | — |
| C | — | 9.0 BSC | — |
| D | — | 7.0 BSC | — |
| E | — | 0.4 BSC | — |
| F | 0.13 | 0.18 | 0.23 |
| G | 1.35 | 1.40 | 1.45 |
| H | — | — | 1.60 |
| I | 0.05 | — | 0.15 |
| J | 0.45 | 0.60 | 0.75 |
| K | 0.09 | — | 0.20 |
| α | 0° | — | 7° |

Copyright© 2023 by HOLTEK SEMICONDUCTOR INC. All Rights Reserved.

The information provided in this document has been produced with reasonable care and attention before publication, however, HOLTEK does not guarantee that the information is completely accurate. The information contained in this publication is provided for reference only and may be superseded by updates. HOLTEK disclaims any expressed, implied or statutory warranties, including but not limited to suitability for commercialization, satisfactory quality, specifications, characteristics, functions, fitness for a particular purpose, and non-infringement of any third-party's rights. HOLTEK disclaims all liability arising from the information and its application. In addition, HOLTEK does not recommend the use of HOLTEK's products where there is a risk of personal hazard due to malfunction or other reasons. HOLTEK hereby declares that it does not authorize the use of these products in life-saving, life-sustaining or safety critical components. Any use of HOLTEK's products in life-saving/sustaining or safety applications is entirely at the buyer's risk, and the buyer agrees to defend, indemnify and hold HOLTEK harmless from any damages, claims, suits, or expenses resulting from such use. The information provided in this document, including but not limited to the content, data, examples, materials, graphs, and trademarks, is the intellectual property of HOLTEK (and its licensors, where applicable) and is protected by copyright law and other intellectual property laws. No license, express or implied, to any intellectual property right, is granted by HOLTEK herein. HOLTEK reserves the right to revise the information described in the document at any time without prior notice. For the latest information, please contact us.